



HOME ENVIRONMENT

Color, Texture, Line, and Shape

Level 1



4-H Home Environment



Note to Project Helper

Congratulations! A young person has asked you to be his or her helper. Your role as a helper is very important to the total educational experience of the young person. Not only will you be providing encouragement and recognition, you will also be the key person with whom the young person shares each of the experiences outlined in this project manual.

You can also help this young person take learning to the next level by taking him or her to paint stores, home decorating shops, craft and fabric stores, and decorator home shows. The seeing and feeling of different textures, lines, colors, and shape combinations can take an individual's learning to a new understanding.

The 4-H Home Environment curriculum is a two-part series. Level 1 is for grades 3–5 and utilizes this manual, Home Environment: Color, Texture, Line, and Shape (4-H-1011-W). Level 2 is for grades 6–8 and Level 3 is for grades 9–12. Both Level 2 and 3 utilize the University of Nebraska 4-H manual Home Environment: Design Decisions (4-H-1012), which is available through your local county Extension office.

As a project helper, your role is to:

- become familiar with the material in this activity guide
- support the 4-H member in setting goals and completing each activity
- date and initial the activities on the 4-H Home Environment Activities Form (found on page 5) as the youth completes them
- help the 4-H member get to know himself or herself, including strengths and weaknesses
- encourage the use of the experiential learning cycle described below

The Experiential Model

The Experiential Learning Model and its five steps help youth gain the most from their experiences through the following five steps:

- **Experience**—Youth participate in an activity so they can develop first-hand knowledge from it.
- **Share**—Youth discuss their experiences and what they learned with others.
- **Process**—Youth identify the most important part of what they learned or accomplished.
- **Generalize**—Youth relate what they have learned to their own lives and experiences.
- **Apply**—Youth discuss how to use what they have learned in their own lives.

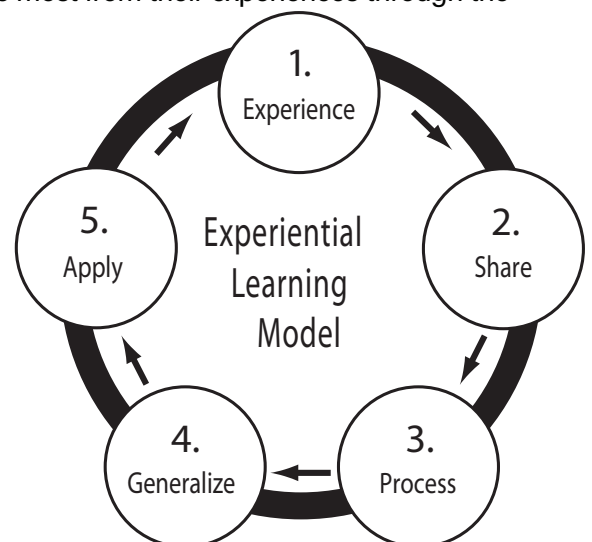

Pfeiffer, J.W., & Jones, J.E., "Reference Guide to Handbooks and Annuals"
© 1983 John Wiley & Sons, Inc.
Reprinted with permission of John Wiley & Sons, Inc.

Contents

Getting Started in the 4-H Home Environment Project 4

Chapter 1

Understanding Design 6
Using Color to Make an Attractive Environment 9
Working with Colors 12
Using Color, Texture, and Line to Create a Hanging Accessory 17
 Wall Hanging 17
 Batik Art 18
 Mobile 20
Caring for Your Room 21
Using Color to Create a Storage Item 22
 Covered Box/Drawer Dividers 22
 Wastebasket 24
 Bookends 24

Chapter 2

Texture with Color Adds Interest to a Room 25
Using Texture to Make Your Room More Attractive 26
 Bulletin Board 27
 Textured Wall Hanging 29
 Wall Sculpture 29
 Box Frame 30
Organizing Your Storage Space 31
Caring for Your Room and Shared Areas 34
Sharing Information with Others 39

Chapter 3

Using Line, Shape, and Decoration for an Attractive Room 40
Planning a Major Project 42
Caring for a Shared Area of Your Home 45
Sharing Information with Others 48

Getting Started in the 4-H Home Environment Project

Your home is a special place. It is where you eat, sleep, play, and work with your family and friends. Your home is where you live.

The 4-H Home Environment project shows you ways to help care for parts of the home and to make living areas more enjoyable.

You will start in a very small way by learning to care for a special space: your room. Making your room attractive and taking care of it can be fun if you know some proper ways.

Exhibit Options

Each level has several options per category from which to choose. It is suggested that you either choose a different topic each year or show how you expanded on the same option (portfolio & furniture categories only). Please see your local county 4-H rules and handbook. Or visit the Indiana 4-H Web site at www.four-h.purdue.edu/projects and check exhibit requirements under the "Home Environment" link.

Preparing Your Home Environment Notebook:

Your Home Environment notebook is a part of the project exhibit and will accompany your furniture exhibit. It might be a good idea to select a sturdy 8½ x 11-inch loose-leaf binder. Label the lower right corner of notebook with the following information:

- Name
- Address
- Club
- County

Added information should be in the following order:

1. List of items that you made with the record of:
 - why this project was chosen
 - time spent (in other words, how long did it take you to make it?)—tell about help from your family, friends, and leader.
 - money spent—list each item and its cost.

2. Your examples of how and where the items will be used.
 - photos—if used, have some action shots of you working on the articles as well as where each will be located.
 - drawing or sketch—whenever photos are not available or practical. (Identify which item you have selected to exhibit.)
3. Chart showing your care of a shared area; include detailed information about the task, the place where it was performed, and the frequency.
4. The subject and comments about what you shared with others (other specifics are recorded on the 4-H Club Record).

Additional Information

Color Samples

These can be paint samples from a paint or hardware store, or color samples you make yourself with paints or colored pencils.

Other Samples

Many hardware or home improvement stores have free samples of wall coverings, flooring, countertops, and cabinet materials that can be used with your design board or portfolio.

Colored Pencils

Use colored pencils when coloring your design board or portfolio. Colored pencils are what professionals use! Keep in mind that the entire area does not need to be colored in, but be sure to apply enough color to show your ideas. Other methods for coloring will also be accepted. These could include (but are not limited to): crayons, watercolor pencils, markers, or printing on the computer.

4-H Home Environment Activities Form

Project Guidelines

The 4-H member should review the Home Environment Manual Level 1 and record activities that were completed this year. The 4-H helper should check the activity and initial on the line. Youth should complete at least 3 activities per year.

Name _____

What I want to do and learn in this project:

1. _____

2. _____

Project Highlights

List of exciting things I did and learned (include dates):

Learn-More Outings:

List any places you visited to gain more knowledge, such as a paint, craft, or fabric store, a home decorator showcase, etc.

Required Activities	Date Completed	Helper Initials
Activity #1: Shaping Up	_____	_____
Activity #2: What a Feeling!	_____	_____
Activity #3: Line 'em Up	_____	_____
Activity #4: My Color-Full Room	_____	_____
Activity #5: Mixing It Up—Part 1	_____	_____
Activity #6: Mixing It Up—Part 2	_____	_____
Activity #7: Dull, Bright, or Just Right?	_____	_____
Activity #8: Picture This	_____	_____
Activity #9: Making a Hanging Accessory (choose one)	_____	_____
▪ Wall Hanging	_____	_____
▪ Batik Art	_____	_____
▪ Mobile	_____	_____
Activity #10: Making a Storage Item (choose one)	_____	_____
▪ Covered Box/Drawer Dividers	_____	_____
▪ Wastebasket	_____	_____
▪ Bookends	_____	_____
Activity #11: Making a Textured Accessory (choose one)	_____	_____
▪ Bulletin Board	_____	_____
▪ Textured Wall Hanging	_____	_____
▪ Wall Sculpture	_____	_____
▪ Box Frame	_____	_____
Activity #12: Picture This (Again)	_____	_____
Activity #13: Awesome Accessories	_____	_____

Place	Date	Place	Date
_____	_____	_____	_____
_____	_____	_____	_____
_____	_____	_____	_____

What You Will Learn in Chapter 1

- to see the use of color in your room
- to use color to make your room attractive
- vocabulary about color
- how to keep your things (personal possessions) organized
- some tasks to keep your room organized and ready for use

Chapter 1

Understanding Design

Design is the use of one or more elements (things) and principles (example: color, texture, line, or shape) to create or make something useful. To use elements and principles of design to create an area that is pleasing to the eye will help you understand how these principles work together. These same principles are used in all visual design career areas, including interior design, graphic design, industrial design, architecture, and fine art.

The principles (color, texture, line, and shape) control the interactions of the elements used in organizing the design as a whole. Successful design combines the use of the principles and elements to achieve a purpose and visual look.

Your purpose and intent drives the decisions you make to achieve the right scale and proportion, as well as the degree of harmony between the elements.

Form can be created by joining two or more shapes, enhanced by tone, texture, and color. An example of form might be a room that we see in three dimensions, including the height, width, and depth.

ACTIVITY #1: Shaping Up

Below are five examples of different forms or shapes. There are five spaces for you to identify an item in your home or an area that looks like these shapes.

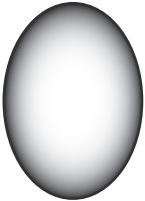
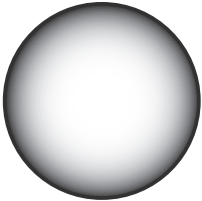
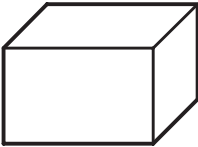
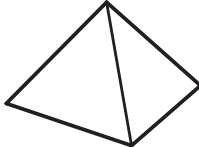
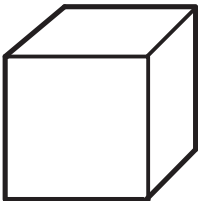
Oval	Circle	Rectangle	Triangle	Square
				

Space is the area provided for a particular purpose. It can have two dimensions (length and width), such as a floor, or it can be three-dimensional (length, width, and height), such as a table. Space includes the background, foreground, and middle ground.

Different spaces convey different feelings and emotions. A large, open space could mean freedom or luxury (open field to run in, large house), but it might also mean loneliness or emptiness (you standing in the middle of a gymnasium with no

one else there). A properly designed small space could convey privacy or coziness (tea room restaurant, back porch swing, flower garden). If not properly designed, a small space can feel crowded, suffocating (closed in), or messy (maybe your own bedroom?).

ACTIVITY #2: What a Feeling!

Identify areas of space that convey different feelings and emotions for you.

	Large Spaces	Personal Feelings
	Freedom	
	Luxury	
	Emptiness	
	Small Places	
	Cozy	
	Private	
	Messy	
	Romantic	
	Crowded	

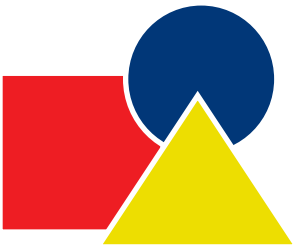

Line is the most basic design element (one-dimensional, flat). Line is the mark made by a moving point, such as a pencil or brush. The edges of shapes and forms create lines. The lines identify a room when linear edges meet, for example: wall to floor lines, wall to wall lines, and wall to ceiling lines. All lines have direction and can have a powerful influence on the mood of the room.

ACTIVITY #3: Line 'em Up

Below are four different types of lines, the influence they create, examples of the line, and suggestions as to where you might see these lines in everyday life. How many other ideas can you come up with? Place your answers below.

Horizontal	Vertical	Diagonal	Oblique
suggests calmness, stability, and tranquility	gives a feeling of balance, formality, and alertness	suggests movement and action	suggests movement and action
sunrise / sunset	soldier at attention	indicates stopping or starting in cartoons	waves

Texture is the appearance or feel of a surface. Texture can be described by words such as rough, smooth, soft, hard, glossy, nubby, or scratchy. Using different fabrics, colors, and accessories can create texture in a room. For example, different fabrics have different textures; satin is very silky and smooth, while burlap is rough and scratchy.

Floors have different textures, too. Stone and wood can be smooth and hard, while carpets can be soft and warm. Some painting techniques such as faux (pronounced "foe"), which is French for false, give the illusion of marbling or antiquing, which creates texture.

Using Color to Make an Attractive Environment

Color graphics and base text in this section are used with the permission of Renate Hering-Shepherd, owner of www.dreamhomedecorating.com/color-wheel-chart.html. See this Web site for more study and understanding.

Beauty is in the way you see things. You see things through your own eyes. These things may be people or articles. Look for beauty in nature, in your home, in paintings—everywhere around you. The more you look, the more you see. You can train your eyes to look for beauty.

Why do you think something is beautiful? Is it color? That's usually the first thing that most people notice. Color can create emotions, set a mood, or warm up or cool down a room without an additional temperature change.

Color is the key to beauty in your room. It works magic! A dull room comes alive with some touches of color. Color can cheer you up and make you feel energetic and happy. It can also depress you and make you feel dreary and grumpy.



ACTIVITY #4: My Color-Full Room

Take a look at your room. What colors do you see? Make a list of these colors.

Which color do you see used most in the room?

Where is this color located?

What is the second most used color in the room?

Which colors are only used a little?

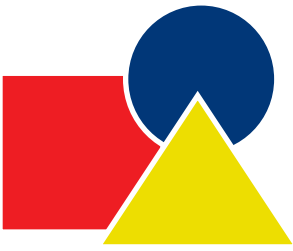

Did you know that there are different types of colors? White, black, and gray are called neutral colors. These are basic colors that are often used along with other colors to help them stand out.

All colors, except for the neutrals, are made from three basic colors: red, blue and yellow. These colors are called primary colors since all other colors are made by mixing two or more primary colors and since red, blue, and yellow cannot be made from mixing any other colors.

Have you ever been with someone when they purchased a can of paint that was not premixed? If you have, you may recall that the store clerk used a machine to mix colors to get the color needed. What the clerk is really doing is adding one or more of the primary colors to a base paint to get the needed color.

Did you know that the grays are really mixtures of white and black?

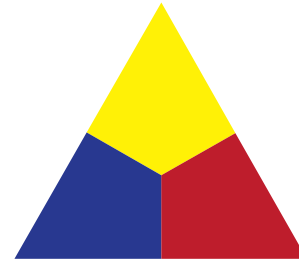

If you mix two primary colors, you will get a **secondary color**. Green, purple, and orange are all secondary colors that are made from primary colors. If you mix yellow and blue, you will make green. Blue and red make purple. Red and yellow make orange.

Each primary color has a **complementary** color (mixed from the other two primaries). Complementary colors are blue and orange, red and green, and yellow and purple. When you align the three primary colors with the secondary and tertiary colors around the color wheel chart, the complementary colors always sit directly opposite each other.



View color images online at: www.dreamhomedecorating.com/color-wheel-chart.html.

Obviously, the fun really starts when you mix primary and secondary colors. This gives you all the fabulous shades of color around the color wheel, for example greenish blues to yellowish greens.

(These are sometimes called tertiary colors, but that term is not used in the same way everywhere.)

Each pair complements, or completes, each other to produce a neutral color. Mix two complementary colors, and you'll get the old murky gray.



Red + Yellow = Orange

Yellow + Blue = Green

Blue + Red = Purple

ACTIVITY #5: Making It Up—Part 1

What you will need:

- 6 cups (drinking glasses, jars, or paper cups)
- water
- measuring cup, ½-cup size
- red, blue, and yellow food coloring

Method:

1. Place ½ cup of water in each container.

2. Using food coloring, do the following:

In cup #1, add 2 drops of red.

In cup #2, add 2 drops of blue.

In cup #3, add 2 drops of yellow,

In cup #4, add 1 drop of red and 1 drop of yellow.

What color did you get in cup #4?

3. In cup #5, add 1 drop of blue and 1 drop of yellow. What color did you get?

4. In cup #6, add 1 drop of red and 1 drop of blue. What color did you get?

If you want to experiment with creating other colors, try mixing different portions of these six containers of colored water in other containers.

View color images online at: www.dreamhomedecorating.com/color-wheel-chart.html.

To further study warm and cool colors in home decorating, go to this Web site:

www.dreamhomedecorating.com/warm-and-cool-colors.html



Hue, Value, and Intensity

As you worked with these colors, did you notice that each one seemed to have a different personality? It is easy to see that each is a different color or hue.

These differences in colors are called the dimensions and properties of color. Each color has three dimensions: hue, value, and intensity.

Hue means the name of the color. Throughout the years, many different names have been given to colors. Orange may be called by many names, such as tangerine, pumpkin, sunset, or bittersweet. These are all hues of orange. How many hues of green can you name?

Green #1

Green #2

Green #3

Green #4

Value refers to the lightness or darkness of the color. Pink is a light red, and maroon is a dark red. The lighter colors are called tints, and the darker colors are called shades. To make tints, add white to the color; to make shades, add black to the color.

To see how this happens, do Activity #6 to make different values of red.

ACTIVITY #6: Mixing It Up—Part 2

What you will need:

- 4 cups (drinking glasses, jars, or paper cups)
- water
- measuring cup, ½-cup size
- red, blue, and yellow food coloring

Method:

1. Place ½ cup of water in each container.
2. Using food coloring, do the following:
In cup #1, add one drops of red.
In cup #2, add 10 drops of red. Set aside.
In cup #3, add 10 drops of red. Set aside.
3. In cup #4, add 1/2 cup of water and following amounts of food coloring:
5 drops of red
5 drops of blue
3 drops of yellow
Cup #4 should now contain dark blackish water

(continued on page 14)

View color images online at: www.dreamhomedecorating.com/color-wheel-chart.html.

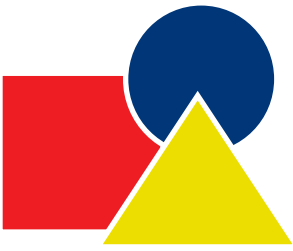

(continued from page 13)

4. Add 1 Tbsp. of the black water to cup #3 (along with the 10 drops of red it already had).

You should now have three values of red. Describe the appearance of each cup.

Cup #1
1/2 cup water + 1 drop red food coloring
Describe the appearance:
Cup #2
1/2 cup water + 10 drop red food coloring
Describe the appearance:
Cup #3
1/2 cup water 10 drops red food coloring + 1 tablespoon black water
Describe the appearance:

You can obtain light and dark colors by changing the amount of pigment (food coloring) and the amount of black. You can also complete this activity by mixing watercolor paints on paper.

Some colors are very bright; other colors are dull, and some are in between. This brightness or dullness is called the **intensity** of the color. Bright green is high in intensity, while dull gray-green is low in intensity. The bright green is pure green with nothing added. The dull green has gray added to give it a dull color. You can add gray to both light and dark colors to make them appear duller.

ACTIVITY #7: Dull, Bright, or Just Right?

Using colored pencils or crayons, find three different values of red and three different values of green. Color these in the spaces below.

	Pink/Light Red	Light Green
Bright		
	Medium Red	Medium Green
In Between		
	Dark Red	Dark Green
Dull		

Personality of Color

Colors have personality traits. Earlier you learned that colors can suggest warmth or coolness. Did you know that they can appear close or far away? Or give a feeling of activity or a feeling of quiet and restfulness?

Remember, warm colors are the ones that make you think of warm things. What colors make you think of sunshine or fire? If you're thinking yellow, orange, and red, you are right. These are the warm colors, which can also be referred to as advancing colors.

Does a blue lake or a shade tree look cool to you? Greens, blues, and purples are the cool colors because they resemble things that make you feel cool.

A blue sky seems far, far away; green fields tend to fade into the distance, and faraway hills or mountains appear covered with a purplish haze. Green, blue, and purple then are colors that seem to be away from us. They are called receding colors.

Remember, each color has:

- **Hue**—the name of the color
- **Value**—the darkness or lightness of the color
- **Intensity**—the brightness or dullness of the color

Colors have personalities.

- Yellow, orange, and red are warm, advancing, active colors.
- Green, blue, and purple are cool, receding, restful colors.

Look at the color chart on page 11 and identify the colors as advancing colors or receding colors.

Yellow, orange, and red are exciting, active colors. Green, blue, and purple are more quiet and restful.

Now look at the same color chart and identify the colors as active colors or quiet colors. Do you notice that the active colors are also the warm, advancing colors and the restful colors are also the cool, receding colors?

Color is so very important to our surroundings and to everything we do. As you work with color and understand color personalities, you will find it fun to use colors for beautiful and pleasant surroundings.

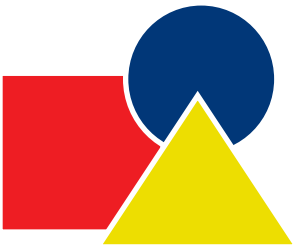

What Color Works in Your Room?

Knowing the relationships of colors and their properties is helpful for making an attractive room. Review the information about warm and cool colors again. Now look at your chosen room.

- Which color is advancing (warm) or dominating?
- Which color is receding (cool) or accenting?

Any color scheme for a room will look better if one color is the major color, or **dominant color**, in the color scheme. Additional colors used in smaller amounts are the **accent colors**.

The most popular color schemes are:

- **Monochromatic**—In this color scheme, the accent colors are tints or shades of the major color. For example, green may be the dominant color with dark green and light green as accent colors.
- **Complementary**—This color scheme uses accent colors on the opposite side of the color wheel from the dominant color. For example, if green is the dominant color, then red and pink would be the accent colors.
- **Related**—In this color scheme, the dominant and accent colors are next to each other on the color wheel. For example, if green is the dominant color, the accent colors would be yellow-green and blue-green.

Look at your room or a chosen room and, with the help of an adult, decide what color scheme is used in the room.

ACTIVITY #8: Picture This

For your notebook, locate magazine pictures that are examples of each color scheme. Mount the pictures on an 8½ x 11-inch piece of paper. Name the dominant color and the accent colors.

As part of the 4-H Home Environment project, you will make a hanging item or storage item for your room. Start planning by first selecting the type of project and the color scheme.

Choices:

Hanging accessory (see pages 17–20)

- wall hanging
- batik art
- mobile

Storage item (see pages 22–24)

- covered box/drawer dividers
- wastebasket
- bookends

Your selection:

Which color or colors will fit with your present color scheme?

Which color or colors are you going to use in making the project for your room?

Using Color, Texture, and Line to Create a Hanging Accessory

Now it's time to apply what you've learned so far. In Activity #9, you will make an accessory to decorate your home environment. To do this activity, complete one of the three options given.

ACTIVITY #9: Making a Hanging Accessory

Option 1—Wall Hanging

A wall hanging is a decorative object, often made of fabric, which is hung on a wall. Wall hangings can add color and interest to your walls, and give you a chance to design something special for your room. It's usually best to use no more than three colors. Too many different colors can give a confused, busy, or distracting feeling.

It takes some thought and planning to create a well-designed wall hanging. Look around for ideas. Nature is full of designs: sea shells, leaves, flowers, fruits, butterflies, and other natural objects. Design ideas may also be found in pictures or magazines. In any case, keep the design simple.

Decide where you want to place the wall hanging. This will help you decide the size and shape.

If the space is tall and skinny, you'll probably want that shape for your hanging. If the space is short and wide, design the hanging to fit that space. Try out the shape you think you want by cutting it out of paper and putting it on the wall with a small piece of tape.

Make the size of your hanging in proportion to the space where it will hang. Don't let the hanging look like a postage stamp on the wall. But don't make it so large that it overpowers everything else near it.

What you will need:

- Heavy fabric, such as burlap or felt, or a piece of drapery fabric to use for backing
- Fabric or felt for design (Use the same material for the whole design—all felt or all fabric.)
- Pattern-making materials, such as tissue paper, lightweight paper, or lightweight cardboard
- Sewing supplies, such as thread, yarn, needles, pins
- Scissors
- Glue (fabric or hot glue) or matching or contrasting yarn to fasten design pieces
- 3/8–1/2 inch wooden dowel or round curtain rod for hanging. Cut longer than fabric is wide.
- Supplies for hanging (T-pins, thin brads or nails, or other picture-hanging supplies, plus cord or string)

Method:

1. Decide on size and shape.
2. Draw design on paper of chosen size.
3. Make a pattern of your design by tracing it onto tissue paper, lightweight paper, or lightweight cardboard.
4. Fasten the pattern pieces to the felt or fabric with straight or safety pins and cut.
5. Fasten the design pieces to the backing using glue, thread, or yarn. If you sew the pieces into place, use embroidery stitches or plain running stitches. (For ideas or instructions about craft projects, visit www.craftown.com or a local craft store. Information about how to do the sewing stitches is available on the Internet or in books on sewing.)

(continued on page 18)

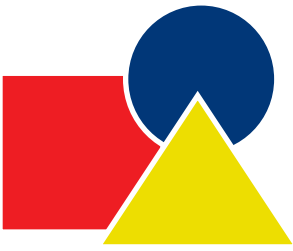

(continued from page 17)

6. For hanging, fold over the top 2 inches, place the dowel or rod under the fold, and glue the edge of the fold to the background.
7. Use two T-pins or thin brads hammered into the wall to hold the dowel or rod. (T-pins are almost invisible and make small holes in the wall.) These should be spaced slightly wider than the hanging so the dowel can lie on top. Another way to display the wall hanging is by securing a cord or string to each end of the dowel and hanging it from a single nail.

Option 2—Batik Art

Note: For a wax-less alternative to completing this activity, visit: ritdye.com

Batik is textile art that involves a special way to apply dye to fabric. The fabric is usually cotton, but you can also use silk. Cotton will be less expensive than silk. Think of batik as reverse coloring or painting. Instead of coloring or painting an area where you wish there to be color or a design on a piece of fabric, you apply wax to this area to keep it color free. Because you will need to use heated wax, you need to have an adult helping you.

Batik wall hanging can add color, interest, or a focal point to your room by utilizing any of the discussed color schemes.

Be certain you understand the earlier description about how to plan a design, which is found in **Option 1-Wall Hanging**.

What you will need:

- white cotton fabric, prewashed (amount needed for wall hanging, such as a large white cotton handkerchief or approximately one yard of fabric)
- stretcher frame or cardboard
- soft lead pencil or charcoal pencil
- crayons or old crayon pieces (Note: Use crayons made of wax. Do not use crayons made of soybean oil.)
- small jelly canning jars
- liquid dye in the color of your choice
- newspaper and plastic drop cloth
- rubber gloves
- iron
- beeswax or paraffin
- electric frying pan
- inexpensive paintbrushes
- paper toweling
- a plastic tub to hold the dye

Method:

1. The cotton piece of fabric should be prewashed to remove any sizing or other treatment that may resist the batik.
2. Decide on the colors and design for your crayon batik. Sketch your design on paper first. After you have decided on your design, use a soft lead pencil or a charcoal pencil and sketch the design on the piece of fabric. This will be easier if you pin or tack the cloth to a piece of cardboard first and keep it tight. This cardboard will also absorb the excess amount of wax when you are ready for that step.

(continued on page 19)

(continued from page 18)

3. Put on your rubber gloves to handle warm wax, to mix liquid dye(s), and for dyeing and wringing out the fabric. This project can become messy with water and may stain countertops or carpets if you're not careful. It is recommended that you protect areas with plastic drop cloth and layers of newsprint or work outdoors.
4. Choose crayons or crayon pieces of colors that you want for your design. Remember that it is better to use one or two colors. Place equal amounts of paraffin and crayon pieces in the glass jars. Use one jar for each color. Then place the jars in the electric fry pan. The fry pan should be filled with water halfway up the sides of the glass containers. Set the fry pan on 260 degrees. The water should boil to keep the wax hot enough to penetrate the fabric.

CAUTION: Don't let the water boil so hard that the jars overturn. Replace the water that evaporates with HOT water to maintain the water level.
5. Using a small paintbrush, paint in the design areas with the crayon/paraffin mixture until the entire design areas are covered completely. As you paint the design, check to make sure the wax has penetrated to the back of the fabric. Look at the back side of the fabric. If the color hasn't gone through, touch up the painting on the back side. Use short strokes to do the painting.
6. Using your plastic tub, mix the liquid dye according to the directions on the dye package. Wear rubber gloves to prevent the color from dyeing your fingers.
7. Dip the batik fabric into the dye and squeeze the fabric to form crackles in the design. Wring out the excess dye from the fabric. Be sure to hold the fabric over the plastic tub when you wring.
8. Place the batik fabric between two layers of paper toweling and then between several layers of newspapers. Iron this layered combination to melt the wax and absorb it into paper toweling. The paper toweling is most important in order to prevent newsprint from transferring onto the fabric. It will take several changes of toweling and newspaper to iron out all of the wax. Continue to iron until the toweling and newsprint come out clean.
9. Discard your leftovers of the unused wax with the canning jars and brushes in the trash container. Do not pour wax down any drains because of clogging problems.

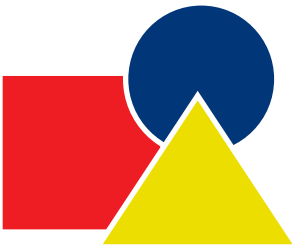

Option 3—Mobile

Mobiles are decorative and fun to make. Mobiles depend upon balance to maintain their design, beauty, and motion. For a first attempt, keep your design simple. A variety of materials can be used for the shapes. The material list below includes some suggestions, but other items might work, too.

What you will need:

- felt or self-adhesive paper and cardboard, construction paper, colored cardboard, bamboo, colored beads, balsa wood, pinecones, miniatures, badges, or other collectible items. Types and shapes that could be used are:
 - birds or fish (both have natural movement)
 - geometric shapes (circles, triangles, rectangles, squares, etc.)
 - diminishing shapes (different sizes of the same shape)
- **Other materials needed:**
 - 16- or 18-gauge wire, very light wire coat hanger
 - ¼-inch dowel or tree branches
 - white glue to stabilize threads
 - monofilament fishing line (clear), string, or thread to hang shapes

Method:

The following instructions explain one way of making a mobile. You may follow these directions or select a different method you have seen or read about.

Make a sketch of your mobile on paper to determine how many parts you need. Cut out shapes from whatever material you decide to use, or organize the items chosen for your mobile. Try out different materials to achieve the effect you want.

Attach thread, string, or line near the top and

center of each shape or item. If you want, you can hang shapes or items from several wires or dowels suspended from each other and counterbalanced.

Assembling Your Mobile

- Cut the first beam (this is the bottom beam) 6 inches long.
- Hang one of the shapes from the end of the beam. Secure the thread or fishing line to the end of the beam. Apply a drop of white glue to secure it.
- Hang another shape in the same manner at the other end of the first beam.
- Tie a piece of fishing line or thread around the beam. Hold the thread from its end and slide it along the beam to find the balance point.
- Secure the thread with fast-drying white glue.
- Cut the second beam 8 inches long (2 inches longer than the one below it).
- Hang a shape from one end of the second beam. Secure the thread with glue.
- Attach the thread from the bottom beam to the other end. Secure with glue.
- Tie a piece of fishing line or thread around the second beam. Find the balance point. Fasten the thread in place with glue.
- Continue in this manner. Make each new beam 2 inches longer than the previous beam. Make as many beams as you need for your design.

Remember to vary the length of the fishing line or thread as you work. Also, keep in mind that the beams must be able to rotate without tangling the threads. When you are finished, attach a piece of cord to the top center of the mobile and hang it where it can move freely.

Caring for Your Room

Are you ever late for school or play because you can't find your shoes or bookbag? Can you find one blue sock but not a pair? Can you find your tennis shoes but not your baseball glove?

One of the best ways to keep this from happening is to put things where they belong. Does someone in your home mention that to you?

There are certain things that you can do for your room each day or on a weekly basis that will make it more enjoyable. This will also make it easier for you to find the things you need when you need them.

Here are some things which need to be done daily:

- put away clothes
- put dirty clothes in the clothes hamper
- make your bed

Here are some things that should be done weekly:

- empty the wastebasket
- dust the furniture

Here are some things that are done only occasionally:

- wash windows
- organize dresser drawers

For this project, you need to record the times you care for your room. This responsibility is an important part of the 4-H Home Environment project.

Looking at Your Dresser or Desk Drawers

Are your dresser or desk drawers messy? Remember, when things are in the proper place, it is easier to find what you need.

You can get rid of clutter and confusion in the drawers by planning and using boxes or dividers to separate items. For example, socks can be separated from underwear, and both can be separated from sweaters or shirts. Boxes or dividers can also keep small things in order. Use containers to separate items such as paper clips, crayons, and pencils. Think how much time you can save if you don't have to hunt for what you need!

How would you rate your dresser drawers?

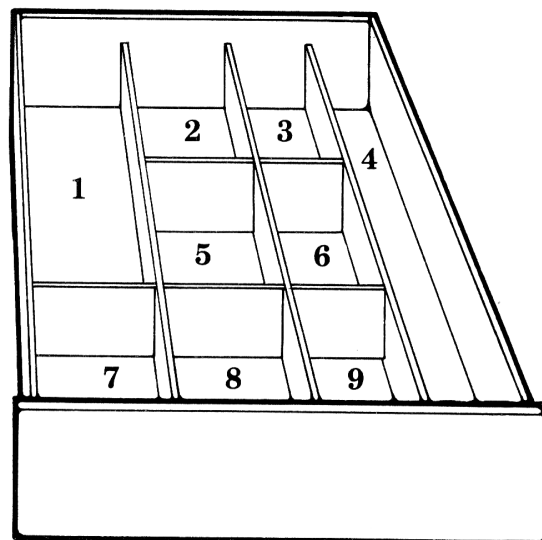

Dresser

- (1) Underwear
- (2) belts
- (3) headbands
- (4) jewelry
- (5) socks
- (6) gloves
- (7) keepsakes
- (8) trading cards
- (9) cosmetics

Desk

- (1) scissors
- (2) pens
- (3) pencils
- (4) ruler
- (5) rubber bands
- (6) paper clips
- (7) notepaper
- (8) crayons
- (9) colored pencils

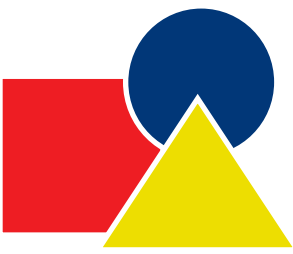

Using Color to Create a Storage Item

Activity #10: Making a Storage Item

Option 1—Covered Box/Drawer Dividers

What you will need:

- Cardboard or plastic boxes, or pieces of cardboard make good drawer dividers. Use a separate box for each group of things you keep in your drawers. Try to find boxes that are clean and sturdy in the right size for each group of articles. Use the lid or the bottom of the boxes, or both.
- You may add color by covering these with wallpaper or self-adhesive paper. Work carefully so that your finished boxes will be neat and clean. You may wish to practice on an old box before starting on your project.

One method of covering a box is listed below. You might discover another way that makes the box look equally attractive.

Method:

- Fold wallpaper or self-adhesive paper with right sides together. Place the long edge of box on fold. The backing of self-adhesive paper should not be removed until it is ready to fasten on the box.

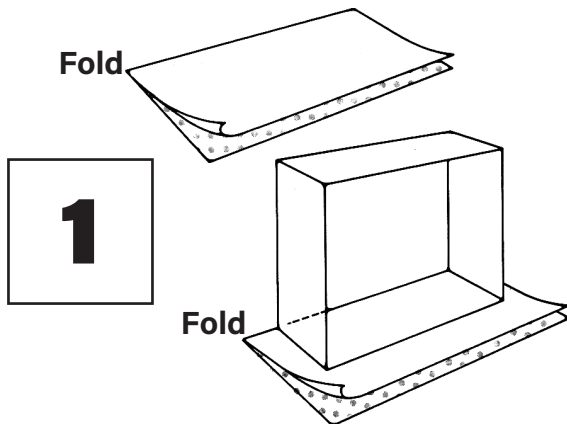

- Trace around the front side of the box. Add 1 inch to this side.

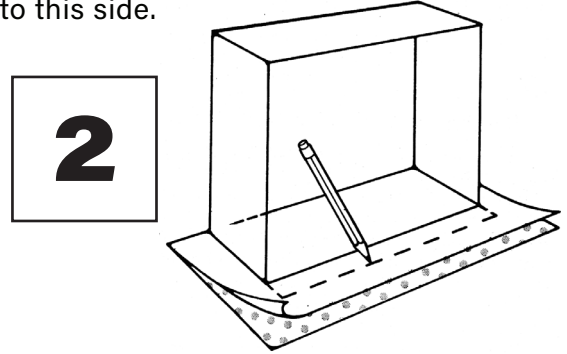

- Cut along outer lines through double thickness of paper. This will cover the inside and outside of one side of the box.

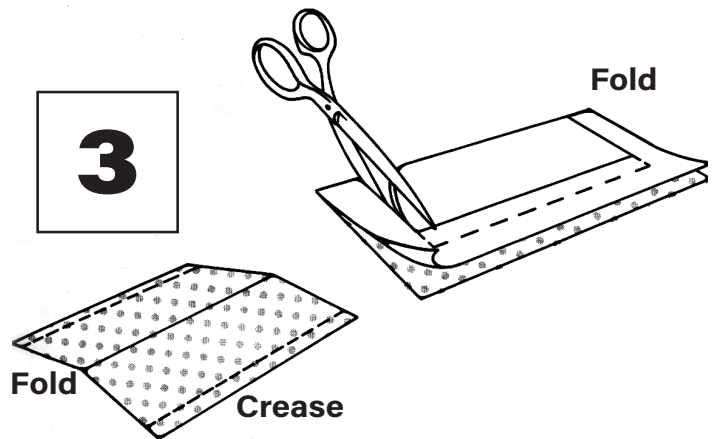

- The fold line should be placed along the upper edge of the box. The creased edges should lap over the inside and outside bottom of the box. Crease lines 1 inch from cut edges. (One 1/2-inch allowance laps under bottom of box. The other 1/2-inch allowance goes on the inside bottom.) Trim edges if necessary for proper fit at corners.

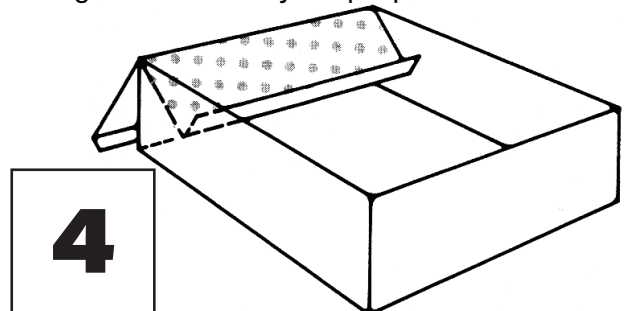

(continued on page 23)

(continued from page 22)

5. Repeat steps 1, 2, 3, and 4 for the other three sides of the box.

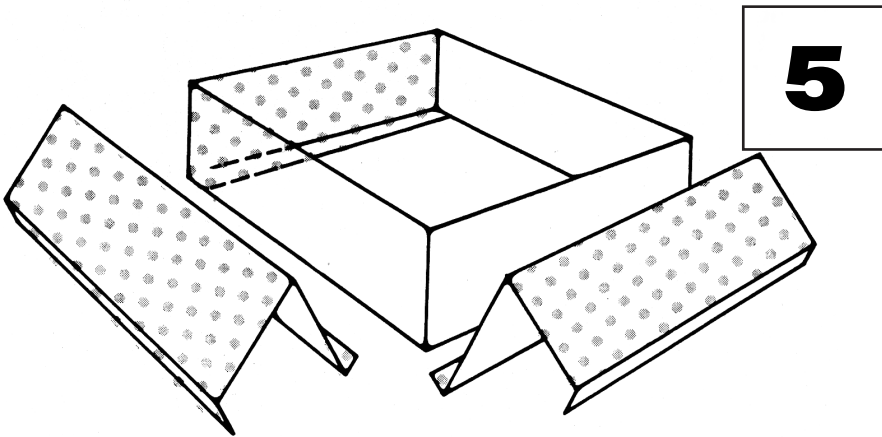

6. Trace around top of box and cut out two pieces of covering paper. Fit one piece of paper and attach it to bottom of box. Smooth out wrinkles or air bubbles. Fit second piece to inside of box following same directions.

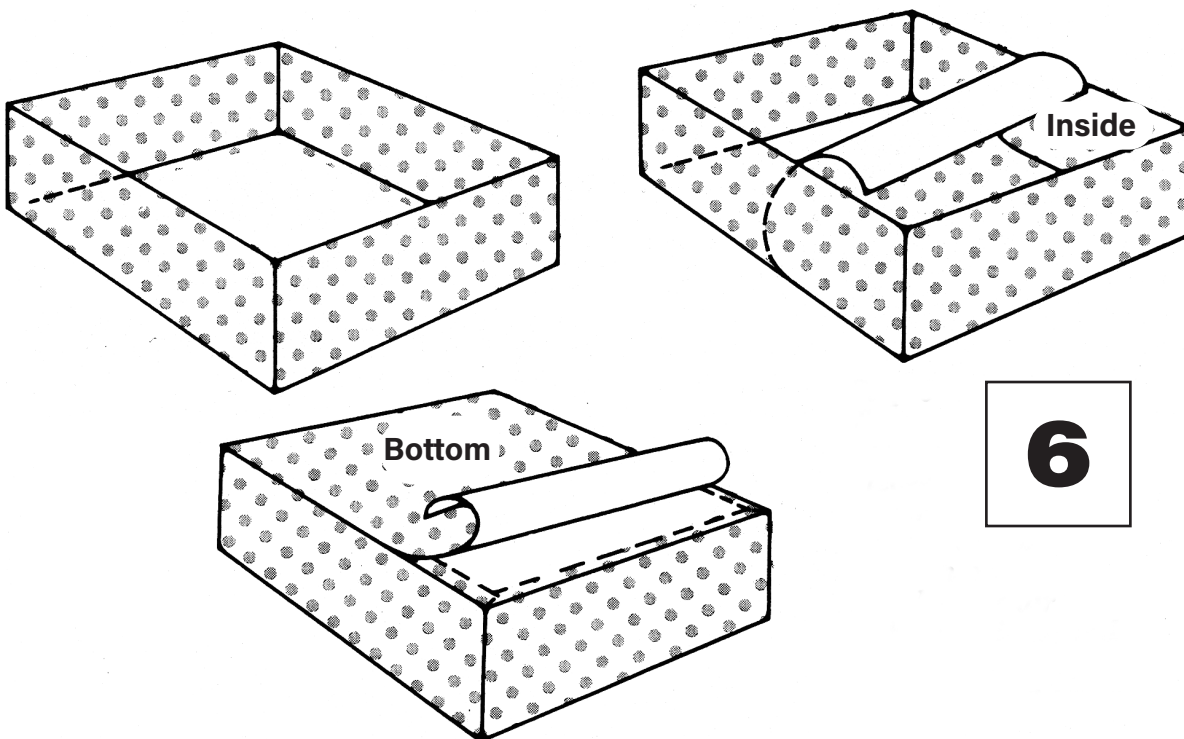

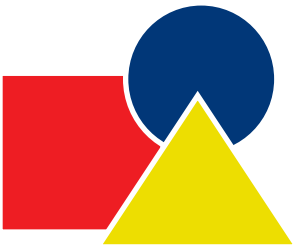

Option 2 Wastebasket

Option 3 Bookends

These two items are listed under the title of storage items. Have you wondered about that?

These two types of holders keep the room organized. Wastebaskets store used materials or discards; bookends hold books in place on a desk or shelf.

Color can be added to your room through either or both of these items.

Wastebaskets can be covered by following the suggestions given under making drawer dividers (see pages 22–23). Of course, a cylinder or round shape, such as a very large ice cream carton, would not require the need to complete the same measurement charts. The circumference of a cylinder is the same measurement as the sides of the box.

Bookends can be made by covering bricks or an object heavy enough to hold books with fabric or self-adhesive paper. Use your imagination as you design attractive bookends.



Chapter 2

Texture with Color Adds Interest to a Room

Your home is a special place. It is where you eat, sleep, play, and work with your family and friends. Your home is where you live. The 4-H Home Environment project shows you ways to help care for the home and to make it more enjoyable.

In Chapter 2, you will add to the information you learned in Chapter 1. Besides maintaining your own bedroom, you will also learn about caring for shared areas in your home.

What You Will Learn in Chapter 2

- to see the use of texture in your room
- to use texture to make your room more attractive
- to organize and store materials that are used to care for your room
- some tasks to keep shared spaces or tools organized and ready for use
- to use the proper materials for cleaning your room or a shared area

Texture is how a surface or object looks and how it feels when touched. All materials have texture. Some examples of words used to describe texture include smooth, rough, soft, hard, stiff, fine, and coarse. A variety of texture adds interest to a room. As was true for color, it is best to limit the major texture emphasis to two or three textures.

Look at your own room. What texture do you see? List the items in your room that have the following textures:

Smooth:

Rough:

Hard:

Soft:

Fine:

Coarse:



Using Texture to Make Your Room More Attractive

Did you list any surfaces or materials in more than one list? Sometimes texture has more than one characteristic. For example, a painted wall can be described as both smooth and hard.

How does texture make a room more interesting and attractive? Texture adds depth or dimension to a room. By placing one object on another, we can make the total object have depth. For example, a wall appears flat until you add curtains and pictures.

Rough, coarse textures seem to advance (as if they move forward), while smooth, hard textures seem to recede (to become more distant or appear to move back). So a small room accessory with a rough texture balances a larger object with a smooth texture. The texture of walls and other background materials also affects the way a room appears.

When combining textures, be sure to consider all the textures and how they affect each other. Too much of the same texture can be monotonous. Examine the texture of the objects and surfaces you would like for your room. Experiment with texture samples from your room to find which combinations you prefer. For example, smooth fabrics are better suited to fine-grained woods, while coarse-grained woods may demand rougher fabrics.

Using texture in Chapter 2 can offer the same kind of exciting experiences as working with color in Chapter 1. Combining color and texture can make your environment even more interesting.

In Activity #11, you will make an accessory for your room using texture but with a planned color scheme. Select one:

- bulletin board
- textured wall hanging
- wall sculpture
- box frame

Which one will you choose?

Activity #11: Making a Textured Accessory

Option 1—Bulletin Board

A bulletin board can add beauty to a room and organization to any area. The function of a bulletin board is to keep order by providing a place to pin or tack small items, such as 4-H ribbons, snapshots, party favors, baseball cards, or messages and reminders.

Decide if your bulletin board is a souvenir or message board. Is it your personal board or one for the entire family? This will help you determine where to place it. After deciding where to hang the board, design the bulletin board to fit the space.

Selecting the Board

The essential part for all bulletin boards is an appropriate size piece of ½-inch insulation board, soft wallboard, cork, or other board that takes thumbtacks and pins easily. You can purchase this at a home improvement or builder supply store. Handle your board carefully to keep edges smooth.

You may decide to cover the board to hide tack holes or a discolored surface. Choose a cover of textured fabric, such as burlap or any coarsely woven fabric. If you cover the bulletin board with a texture, it can also have color. For example, add color by choosing orange burlap.

Think ahead to decide how you plan to hang the bulletin board when it is finished. Some hanging methods require putting parts of the fasteners into place before covering the board with fabric. Discuss this with your adult helper, especially for large heavy bulletin boards that will require stonger hanger materials.

Covering the Board

- Cut the fabric (on the grain) 6 inches longer and 6 inches wider than the board.
- Dampen the fabric because as it dries, it will shrink, thus eliminating wrinkles in the fabric.
- Center the board on the wrong side of the fabric (3 inches of fabric on all sides).
- Stretch the fabric and temporarily fasten at the back of the board with masking tape.
- Glue or tack the fabric approximately 2 inches apart.
- Hammer tacks in center of each side first; then work toward the corners to keep the grain straight. Do not drive the tacks all the way in until they are correctly located.
- Miter the corners (see diagrams on page 28).
- Instead of mitering the corners, you can overlap the extra amount of fabric at the corner and hold it with one or two tacks.

Optional: Framing a Bulletin Board

You may want to consider framing your bulletin board. Why not use a large picture frame with rather simple lines? A coat of paint or a finish that will blend with other colors in the room will freshen the look of an old frame. You don't have to refinish it.

The frame must be thick enough for the covered board to fit. You can build a new frame from simple molding purchased from a home improvement or builder supply store. Ask an adult to help you. Miter, glue, and nail the corners before the glue sets. This task requires a workshop and proper use of tools.

(continued on page 28)



(continued from page 27)

Hanging a Bulletin Board

You can hang bulletin boards from multistrand picture wire. Before measuring the needed length of picture wire, find a number of different points on the back of the board.

Measure from A to B to C, and add 4 inches. Some very heavy bulletin boards may require a double thickness of wire. Double only the measurement from A to B to C. The extra 4 inches are for wrapping the ends securely. Cut and attach the picture wire to the bulletin board. Remember, the picture wire should not show above point B.

It's time to call for help again! Have a family member help you decide what type of hook works best on your house walls. Hang the bulletin board securely against the wall.

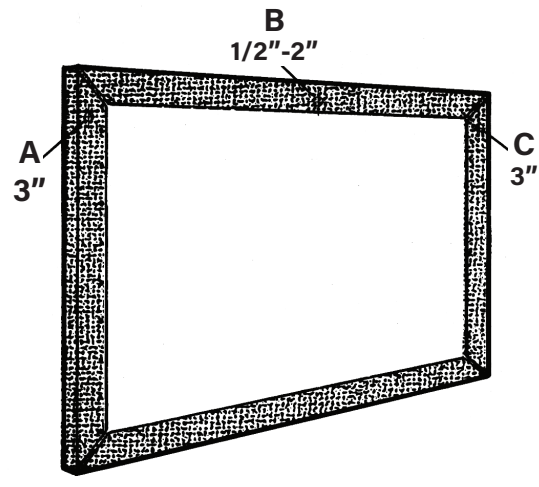
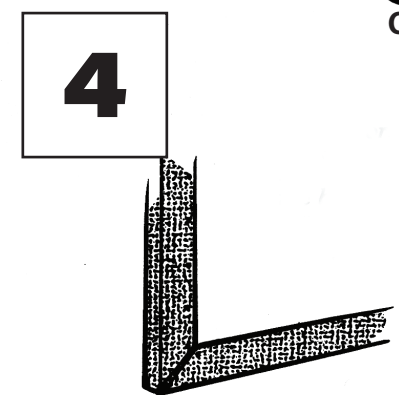
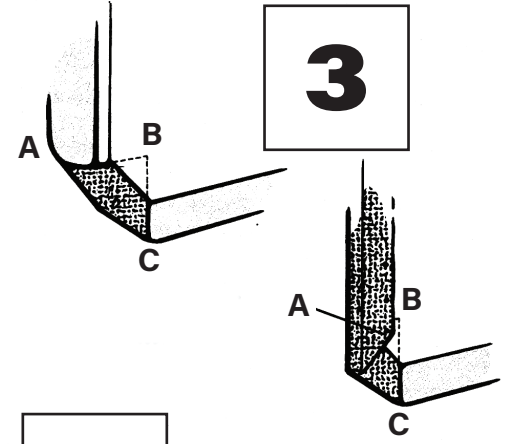
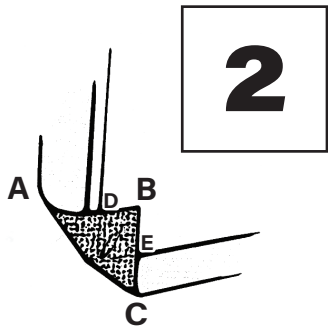
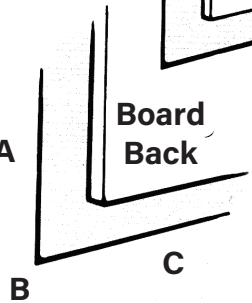
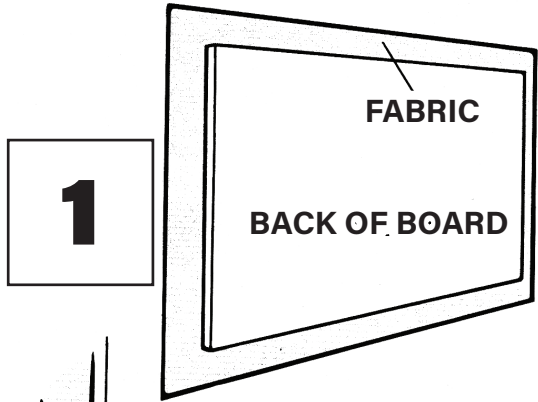

Option 2—Textured Wall Hanging

A wall hanging is a decorative object that can emphasize texture and add interest to your room. Look around for ideas to plan your wall hanging. When you begin, combine no more than three to five textures. Use fabric to add texture as well as color. Other items that can add texture are molding clay, gadgets, memorabilia, and craft items. Think of surface textures and shapes that may add depth and dimension.

Decide where you want to place the wall hanging. Be sure that the size and shape of your wall hanging is proportional for the space on the wall.

Consider these materials for your wall hanging design: seeds, nuts, shells, pinecone pieces, tree branches, a butterfly collection, yarn, or metal. Use a background material that will include one of the textures that you wish to enjoy in your room. The background can be a basket, placemat, piece of wood, fabric, wire, or whatever you feel would best display your texture items. Be sure the background texture contrasts with the attached items.

Prepare the wall hanging properly to mount on the wall.

Additional information about how to make a wall hanging can be found on pages 17–18.



Option 3—Wall Sculpture

Small containers make good construction items for a wall sculpture. The containers may be small boxes, cans, lids, or any items that encourage your creative expression. Add four boxes or sketch areas for four ideas.

You may select containers of various sizes, but be sure to include two or three different textures. These different textures may be found in the type of container you select or a container cover made from fabric, paper, or another covering of your choice.

Arrange the containers in various patterns before fastening them together to a backing or mounting board. The backing may be a large container or a flat surface that can be used for attaching the containers.

Try sketching different ways to arrange the containers first. Then, as you arrange a design you like, begin to fasten it for hanging. Remember to use at least two or three different textures.

Suggested steps to follow in making a wall sculpture:

- Arrange the boxes in various ways on the mounting board until you find a design you like.
- Make a sketch to refer to as you work.
- Plan the texture color pattern, and mark each box with the initial color or cloth you will use.
- Cover or paint the boxes. You may want to paint some and cover others with cloth.

(continued on page 30)



(continued from page 29)

- Apply glue to the edges of the boxes that will form the first layer; press them on the mounting board.
- Glue the remaining boxes on top of the first ones.
- When the glue is dry, your wall sculpture is ready to hang.



Option 4—Box Frame

You can display small objects in a box frame or shadow box. This is a fun way to display collections or personal treasures. Box frames can be made several ways. You will need to decide what you want to put in the frame.

Here are a few ideas to start you thinking: dried beans, pasta shells, macaroni, nuts, small bottles, buttons, a butterfly collection, shells, or miniatures.

Your box frame can be compartments of equal or varied sizes if you like. Some displays need glass covers, while other displays are open. You can use a wooden beverage case or an old printer's type case. Or you may want to select an ecology-type box or shadow box from a craft store.

If you use a wooden beverage case or a printer's type case, clean it first. The backboard may be left natural or covered with a suitable material. If you want to add some color to your texture project, try painting the case. Purchase a glass cover to fit over the front if desired.

Attach the display objects to the background in one of the following ways: screwing, gluing, wiring, and pinning. Remember, the method of fastening an item may decrease its later value. You can also display objects without attaching them to the background.

Organizing Your Storage Space

In Chapter 1, you organized your desk or dresser drawers. In this chapter, you will learn some basic storage principles. The same storage principles apply to other storage areas of your home as well. Choose one of the following areas to organize:

- your closet
- a workshop or tool storage area
- your choice

Making Your Closet Convenient

A clean, orderly closet with the needed accessories in it is a joy to use and a great help in keeping your clothes in good condition.

Take a look at your closet. Are you using the available space to the best advantage? Too many closets have wasted space. Can you do anything to make more storage space? Start by making a list of things that need to be stored in your closet:

Items to Store in My Closet

If your family is like most families, you can always use another closet. Maybe the answer is not to add another closet. Maybe you can find unused space in the closets you have and put this space to use. Even a small clothes closet can be organized to hold lots of clothes and keep them in good condition, ready to wear. Look at the clothes in your closet. Are there any clothes that you have outgrown or don't wear anymore? Should you give them to another family member or to a charitable organization? Talk it over with your family before you finalize your decisions.

Adequate storage is more than providing space to store your clothes. Organized storage also means that things should be easy to see and to reach. Things used together can be stored together. This practice can save you time finding your clothes as well as providing an orderly room.

It is important to plan carefully the closet accessories that you will use. Rods, hooks, and shelves that are properly located make it easier to keep clothing in good condition and to keep the closet in good order. Smaller items such as belts, accessories, and shoes can be difficult to store neatly. If you have a swing-out closet door, the inside surface of the door might provide space for attaching special closet accessories to organize these items. The addition of shelves and half shelves can also provide more storage space.



Consider adding some of these items to your closet to make it more convenient:

- shoe rack or bag
- metal bracket or hook on which to hang articles such as your jacket
- mirror (do you have a place on the door for a half- or full-length mirror?)
- half-shelf for sweaters or shirts that you keep folded
- second short rod for pants, shirts, and skirts (this can increase the hanging space as much as one-third)
- hanger designed to hold more than one garment

These are just a few ideas to get you started. You may find other ideas that you like better for your space and storage needs. Take a tour of your local home improvement store to gather ideas on how you might organize and store your items. You can also get some great ideas from the Internet by searching for "closet organizers" or "closet storage."

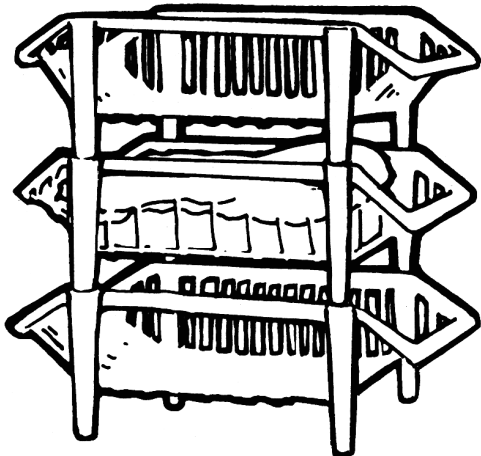

Making Your Shop or Tool Storage Convenient

Having an organized workshop area helps you find tools and supplies when you need them, just as order in your closet helps you find your clothes and belongings.

To get started on this adventure, work with your family and decide what should be stored in the tool area.

Items to Store in the Tool Area

Pegboard is an excellent and flexible material to use for storing workshop or garden tools and other large items. You can buy pegboard fittings (hooks and hangers) to fit different size handles and shapes. Perhaps you could mount a pegboard panel on the wall above the workbench or where needed. There are several ways to mount pegboards, but remember that you need a space for the pegboard hooks to fit behind the pegboard.

After you have installed a pegboard panel, decide on the best tool arrangement. Then draw or trace an outline of the tools on the pegboard, using a permanent marker pen. Anyone using a tool will then know where to store it.

You can make storage units or organizers for holding smaller items like screws and nails. One method uses baby food jars and lids. Fasten the jar lids to a 1- to 3-inch wide board. Then mount the board under a shelf or cabinet with screws or nails.

Place screws, nuts, and other small items in the baby food jars. Then attach the jars to the lids. Presto!—easy to see, easy reach. You can purchase this same type of item at your local hardware or home improvement store, but save money by making your own.

You can store other workshop items, too large for baby food jars, in boxes or trays with labels.

A toolbox could be a new or used tackle box. It is difficult to make a neat arrangement in most toolboxes unless you have a box with several sections. If there is a small tray in the box, you can place the smaller items (nails, screws, hooks, etc.) there to keep them separate from the tools. Larger items such as a hammer or crescent wrench can be placed in the bottom of the toolbox.

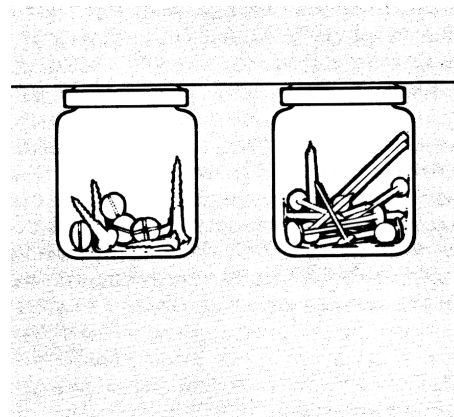
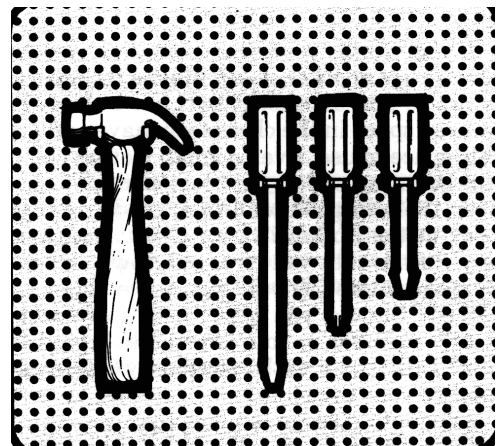



Caring for Your Room and Shared Areas

In this project, as you care for your room and a shared area, you should have responsibilities for helping with the care of your home.

Here are some things that need to be done. Can you think of some additional tasks to add to these lists?

Daily

- put away clean clothes
- put dirty clothes in _____
- make your bed
- _____
- _____
- _____

Weekly

- dust the furniture and bookshelves
- empty wastebasket
- clean mirrors and TV screens
- sweep floor
- _____
- _____
- _____

Occasionally

- wash windows
- organize drawers and closets
- sort through and remove unwanted or outgrown items
- clean grill
- clean tools
- _____
- _____
- _____

Preparing Your Cleaning Kit

As you clean your room and help clean other areas, you will notice many different surfaces and textures. Earlier in this project, you identified some of them. Proper care for these surfaces helps keep them looking nice and increases the length of use. Having an attractive room is more fun when you know how to care for it.

Caring for the surfaces in your room can be fun, if you have the proper tools. For this portion of the project, you will make a cleaning kit. This kit can be used to clean your room or other areas of the home.

The purpose of a kit is to keep articles together that are needed to do a job. For instance, when you clean your room, do you get a dustcloth from the drawer, polish from the closet, and floor cleaner from another storage place? If you do, a kit would help you keep these cleaning articles together, and then the only storage space you need is for the one kit.

A kit can be a sturdy cardboard box that is large enough for all of the materials you need. You may want to cut handles in the ends so that you can pick the kit up easier. You may want to cover the kit with paper or some other textured material to make it more attractive.

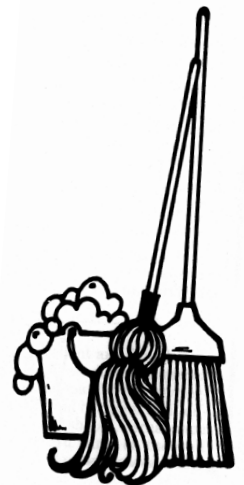

Other items besides cardboard boxes that can be used for kits are plastic dishpans or carriers, wooden boxes or crates, and metal containers (especially for kits that have flammable substances).

Below is a list of suggested items to include in specific cleaning kits. Feel free to add other items that you use for your cleaning jobs to these lists.

Cleaning kit for a room in your home:

- cloths for cleaning
- cloths for polishing
- polish or cleaner
- glass cleaner
- vacuum cleaner bags

Cleaning kit for the grill:

- old rags for washing
- brushes for scrubbing
- detergent
- aluminum foil to line the grill
- steel-wool pads or scratchers

Hints to help cut time and costs:

- apply silver polish with a damp cloth to remove crayon marks from linoleum
- wash dustcloths frequently, then rub in a small amount of liquid wax
- wax the dust pan with no-rub liquid wax to prevent dirt and lint from sticking to it
- clean stains with baking soda when a cleanser is needed

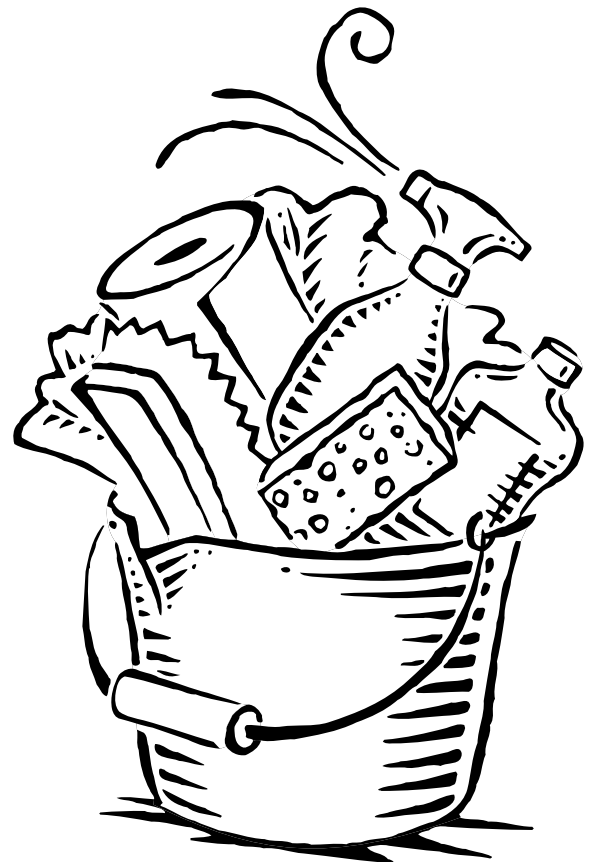



Caring for Your Room

Beginning date _____, 20__.

Place an X in the space each time the task is performed.

You may add to the list of tasks you plan to do.

	Daily 1	Daily 2	Daily 3	Daily 4	Daily 5	Daily 6	Daily 7
Daily							
Put away clean clothes							
Put dirty clothes in hamper							
Make your bed							
	Week 1	Week 2	Week 3	Week 4	Week 5	Week 6	Week 7
Weekly							
Dust furniture and bookshelves							
Empty wastebasket							
Clean mirrors and TV screens							
Sweep floor							
Occasionally							
Wash windows							
Organize drawers and closets							
Sort through (and remove) unwanted outgrown items							
Clean grill							
Clean tools							

To print off a complete "Caring for Your Room" form that will allow you to complete a month's worth of tasks, visit the Indiana 4-H Web site at www.four-h.purdue.edu. Choose "Projects," then "Home Environment," then "Forms."

The Right Cleaner for the Job

Let's look at some common surfaces in a room and what special cleaning products are appropriate to care for them.

Bookshelves

Here is how to clean and arrange bookshelves. First, remove all items from the shelf, and then dust and polish the shelf. Clean each item before you replace it on the shelf. If there are books on the shelves, dust them with a clean, dry cloth because a polish may stain the pages or the book cover. Arrangement of articles on your shelves can add to their decorative value and can also provide you with variety.

Woodwork

Washing woodwork with water is not recommended because it leaves a dull finish and is a time-consuming process. Instead, use a cream furniture wax or a clean-up wax. It may be used on any kind of wood (light or dark) that is finished with paint (except flat), enamel, varnish, lacquer, etc. To save time and energy, use both hands when you clean. Using a cloth first wrung out of cold water then saturated with wax, clean a small area with your right hand. Immediately wipe dry with a clean cloth, using your left. You'll be surprised how quickly and easily a large area can be done. It takes a bit of practice, but it is soon worth the effort!

Outdoor Grill

Cooking outside is a very popular activity in the summer, but unless some precautions are taken, the cookout area can become very dirty.

The best way to clean the cookout area is to take steps to keep it clean before you use it. For example, before you use the portable grill, place aluminum foil in the bottom of the tray and add the charcoal. This will help you keep the tray clean since the ashes can easily be thrown away by removing the foil. On gas grills, scour/brush off the grill, then coat the grill surface with cooking spray or oil. This will help with clean-up.

Wash (*maybe* scour) the grill rack after each use.

Keep utensils such as brushes, spoons, tongs, and pans for sauce or other food items on a tray to free the area of drips and spills.

If the cookout area has a cement or brick floor, sweep and wash it with soap and water. Always keep papers and other trash picked up around the grill area. This will give it a much neater appearance and presents a more appetizing environment.





Walks, Driveways, Patios, and Garages

Keep these outdoor areas clean by sweeping with a broom (not the one used for cleaning inside the house). Grassy edges along and around any of these areas are neater in appearance when trimmed.

You may need to apply a wood preservative periodically to the wooden floor of a porch, patio, or deck. The wood preservative prevents rotting.

Clean muddy paved walks and driveways with a hose. Remove tar or grease with stain remover to keep from tracking the stains onto wooden porches or inside the house.

The garage may be more than a place to store the car, truck, or van. It could also be the storage area for wagons, tricycles, bicycles, sports equipment, lawn mowers, garden tools, and outdoor furniture.

You may want to look and decide if that shared area needs cleaning. Keeping everything in its proper location after use will make the garage easier to keep in order. Occasionally sweep and/or scrub the floor.

Tools

Have you ever had to care for tools? Clean tools last longer. Each time you use the tools you should do the following:

- Scrape soil off shovels and flat tools with a small putty knife.
- Clean with water, and dry thoroughly with an old towel or rag.
- After cleaning, rub with machine or vegetable oil to prevent rusting.
- If your tools have rusted, rub them down with coarse sandpaper or steel wool. (Use gloves to protect hands.) Then, rub with oil.
- Occasionally, sand wooden tool handles to remove splinters and roughness. Rub down with linseed oil.

Sharing Information with Others

What have you learned in the 4-H Home Environment project? One of the easiest ways to decide what you have learned is to prepare a way of sharing it with someone else. This might be a "how-to-do" section of the project, or it might be examples of many different items that show the use of texture.

A demonstration is showing something you have learned and telling others about it at the same time. Demonstrations include action demonstrations where you teach others about your project. Here are demonstration ideas for:

- How to Clean Tools
- How to Make a Cleaning Kit
- How to Cover a Bulletin Board

What You Will Learn in Chapter 3

- to see the line, shape, and decoration in your room
- to use line and shape to make a room more enjoyable
- to select accessories and plants to complement your room
- to properly care for furniture finishes

Chapter 3

Using Line, Shape and Decoration for an Attractive Room

There are many things to learn and do to make your room attractive and pleasant. Whether you live in an apartment, a mobile home, a condominium, or a house you will learn to make it more enjoyable place. You will add to the design information you learned in previous chapters.

Design is what makes a room interesting or dull. Furnishings and accessories may seem more attractive as you grow in your understanding and appreciation of good design. In addition to color and texture, other elements of design are lines, shape, and decoration.

The line and shape of things help to create a bold, active, restless atmosphere or a quiet, gentle, restful room. Lines can create optical illusions. They give direction and movement to a room or object.

Vertical lines are formal and elegant; they add the illusion of height. Horizontal lines are quiet and restful; they can add the illusion of width to an object.

Diagonal lines are active and restless, directing the eye more than one way. Curved lines are graceful, quiet, and comfortable. A large, tightly curved line reminds us of a spring ready to jump.

Fine lines give a feeling of lightness. Heavy lines give a bolder appearance.

A vertical straight line says: "Stand straight, stand tall." It is a dignified, formal line.



A horizontal line is a quiet line. It invites you to rest.



A diagonal line says, "Let's go!" It is active. It can also be a very restless line and make you wonder which way to go.



A curved line is gentle, quiet, and restful. A large curve may be a sleepy line.



A fine line may suggest daintiness.



A heavy line suggests boldness.



A tightly curved line says, "Watch out! I am about to spring!"



Horizontal lines can add width to a shape, while vertical lines add height.



Changing line direction can produce an optical illusion. These lines measure the same, yet the direction of the end arrows makes the one on the right look shorter.

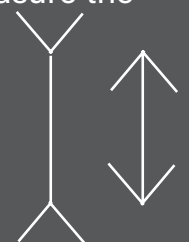

A line can be imaginary.



The shape of an object is formed by joining lines. Form is another word for shape. Curved lines join to make a circle. Straight lines join to make rectangles, squares, triangles, and others.

Shapes also create feelings and illusions similar to those of lines. When you look at shapes, notice your reactions to them. Patterns appear when several lines and shapes are used together. Grouping several shapes can reinforce the original line or create an illusion of an opposite pattern. For example, a number of circular objects could be arranged to form a rectangle, while a curved line of a vase may have vertical strength.

Decoration may be the material the object is made of, such as the grain of the wood or weave of the fabric. The decoration may be an applied portion of an article. An example might be a large button in the center of a pillow.

Other elements of design will be studied in advanced levels of Home Environment. Proportion, scale, balance, rhythm, and emphasis will be included at those levels.

Activity #12: Picture This (Again)

Select two magazine pictures of rooms: one that appears strong and sturdy and one that appears graceful. Note the predominant shapes in each picture and list them. Add these pictures along with detailed information to your portfolio project notebook.

Now take a look at the shapes in your room. Is there a dominant feeling to your room? Is the same line or shape frequently repeated in different objects?

Accessories for My Room		
Item	Line	Shape
desk	straight	rectangle

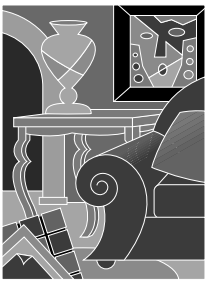

Planning a Major Project

It's easy—and fun—to turn an old room into one that is bright and new-looking. Or if your room is brand new, there are still many things you can do.

Your room is a private world at home. There should be space for your clothes, hobbies, books, and other things you may want to have in your room. You need space in which to use your things and also plenty of storage space for keeping them.

Your room should be colorful and bright. It can be, you know, and you'll enjoy it much more if it is. Most important though is that it be a restful room for comfortable sleep.

This is a lot to ask for any room, isn't it? But yours can measure up if you give it some thought and put your imagination and ability to work.

Don't worry if you can't make all the improvements you'd like at one time. Think of how you'd like your room to look when you've finished, and work toward that goal, making improvements as you can. Try to earn the money—or some of it—for the work you plan to do. This will make you feel more independent as you start to make additions.

Improvements need not cost a lot of money! Some very attractive rooms for teenagers have been done at little cost. It's just a matter of knowing what is needed for your room, planning ahead, learning some skills, and doing the job.

Improving a room can be a family project, and working together on ideas, plans, and activities can be fun. Perhaps you share a room with a brother or sister. If so, talk it over and make your plans together.

Now it is your turn to plan a major project for your room. What atmosphere or feel do you want? Keep in mind the activities for which your room is used. What lines, shapes, or patterns do you need?

My room design needs:
My goals for this project:

Selecting Accessories for Your Room

You may want to make or select three to five accessories for your room. Accessories combine color, texture, and shape. Accessories can serve two purposes. They can be useful items, such as lamps, pillows, clocks, and desk blotters. Other accessories are enjoyed for their beauty or sentimental value alone, such as pictures, hobbies, collections, and sculptures.

Decorative accessories may also be useful, but the decoration should not detract from their functional value. Shape is a necessary part of the design of any object and is important to its purpose or use. When selecting an accessory, look first at the basic shape.

Many times the shape of accessory material provides a good design by itself without added decoration. In other instances, added decoration can strengthen the design. For example, adding a small border of trim to a desk blotter can strengthen the shape of the blotter and not interfere with the use. It could brighten an otherwise very plain desk.

How many accessories should you use? That depends on how much space you have, how you use the space, and the kinds of accessories you use and like. A room with no accessories looks bare and unused. Too many accessories make a room look crowded and cluttered. So, a good rule to follow is to choose a few things to display at one time, storing the others. This allows you to make interesting changes in accessory arrangements from time to time.

You might consider accessories for a study center, such as bookshelves, pencil holders, file boxes, letter racks, or an expandable file. Other areas you could choose to accessorize are a reading area, outdoor living area, dressing area for table games, or hobby area. Or maybe there is another area in your home you would like to work with. Pillows, plants, folding screens, magazine racks, candle holders, collections, displays, art objects, wall hangings, pictures, photographs, or small tables are other accessories to consider.

One area you might choose is a desk area, including surrounding wall space and some floor space. Useful accessories include the following: clock, calendar, lamp, desk blotter, holders for pens and pencils, paper clips, plastic tape, book rack, file box, world globe or maps, etc. Also, keep in mind decorative accessories, such as pictures, plants, small sculptures, or any small article you especially like.

Plants deserve consideration as an accessory. For information on growing plants in the home, contact your county Purdue Extension office or go to the Purdue Extension Garden TIPS Web site: www.ces.purdue.edu/gardentips/index.html . Or participate in your county's 4-H Floriculture project.

Like other accessories, plants have color, texture, and form (shape). Most houseplants are a shade of green, but other colors are also found in plants, such as reds, yellows, and even blues and purples.

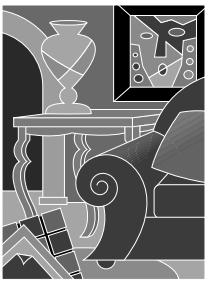

The shape of the leaves and their growth pattern give texture to the plant. The fine leaves of an asparagus fern give a lacy, delicate texture to the plant. Cactus has a prickly texture, and the leaves of a rubber plant have a shiny, waxy surface.

Many plants are rather circular in form. Some plants, like the snake plant, grow in a rigid, straight, upright form. Vining plants, such as ivy, trail downward and soften the lines of a room.

Many places in the home are suitable for growing plants. Large plants are sometimes used alone, while smaller plants can be grouped together or arranged with other accessories.

Activity #13: Awesome Accessories

List two or three useful accessories and one or two decorative accessories to be used for a room. Make your plan by filling in the spaces below.

Kind of Area:			Size:	
Useful Accessories	Material	Shape	Color	Texture
1)				
2)				
3)				
Decorative Accessories	Material	Shape	Color	Texture
1)				
2)				

Practice some arrangements until you develop one you really like.

Do you know the cost of the objects you plan to add as accessories to your room? Perhaps this is the best time to discuss a budget with other family members. Whether you earn the money or not, it is wise to discuss your plan with others in order to reach a decision that will be compatible with other home projects.

How much money do you have to spend on this project? What are the prices for various accessories you might purchase? How much money will you need to buy the materials for an accessory you wish to make? Have you added cost for your time?

A prepared budget will provide guidance in reaching a decision. Be prepared to explain the reason you did or did not spend the budgeted amount of money.

Caring for a Shared Area of Your Home

In the previous chapters, you were asked to assume more responsibilities for the care of your room. We hope you are continuing with those responsibilities. In Chapter 3, you will learn more about caring for additional shared areas of your home. You will also learn about furniture finishes and caring for them.

Caring for Furniture Finishes

As you care for the living areas of your home, there are many different types of surfaces, each with unique care requirements.

Using the proper care for furnishings maintains their beauty and protects the finish. The finishes may be plastic, marble, upholstered with fabric or another material, or wood (painted, oiled, or another finish). Even though furnishings receive regular care, improper cleaning products or methods can leave them dull and streaked.

A commonly used cleaning procedure is dusting. You can do a fast and effective job of dusting if you work out a plan.

You will need two kinds of dust cloths:

- A dry, clean, lintless cloth for pictures, lamps, and small articles. Cheesecloth, knitted fabric, or terry cloth work well.
- A treated dust cloth for furniture. If you'd like to make your own treated dust cloth, ask for help so that the oil or polish only lightly moistens the cloth.

Procedure:

- Dust small articles and put them on a table (or bed). Use a dry cloth.
- Dust furniture. Here is where you can make both hands work. Use a treated dust cloth. A dust mitt on each hand cuts dusting time in half! Begin at the top of a piece of furniture and work down. Be sure to go over the whole piece.
- Put everything back in place.
- Shake dust cloths outdoors and be sure to put the treated ones in a closed container (stored in covered glass or metal containers so they will not start fires). The untreated ones can go into the regular wash.

Study the following information before you begin major cleaning responsibilities. These tasks are usually done only two to three times per year.

Plastic Furniture

Plastic furniture can become dull and shabby from excessive wear or when harsh abrasive cleaners are used for its care. To keep plastics looking new and help protect against wear, they should be cleaned and waxed periodically. A good choice for care is a creamy liquid wax or a multisurface cleaner-polish.

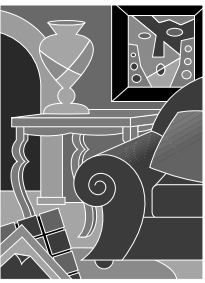

Badly worn areas or areas spotted by rust, fruit juices, permanent ink, or dyes will have a new look if restored with a single step auto-cleaner wax. It will not mar the surface as harsher abrasive cleaners can. Put a little of the wax on a thick pad or clean, soft cloth and rub on the worn area using long, even strokes. Rub with the grain or length of the pattern. Do not use a circular motion as it might cause swirl marks.

Some low-cost plastic furniture may be designed to simulate a wood-grain pattern. These finishes are printed on plastic surfaces. They do not always form a firm bond with the plastic and may be sensitive to the cleaners in furniture care products. If in doubt, always test a product in an unseen area.

Acrylic furniture (Plexiglas® and Lucite®) has a surface that is highly polished and resistant to many stains but scratches easily. Wash this furniture with a mild soap or detergent and water, or use an ammonia and water solution. (Soft cloths or sponges totally free of grit should be used.) Rinse with clear water and blot dry with soft, clean material such as cotton flannel or chamois.

To remove minor scratches and protect the beauty of the surface, use a single-step auto cleaner wax as suggested for plastic furniture. After polishing, wipe again with a clean, damp cloth to help reduce static electricity.

Marble

Marble is not as durable as it appears! Most things that stain wood—oil, citrus acids, alcohol, and tobacco—will also stain or dull marble if not removed immediately. This is also true of the newer molded-type marble that is made from marble dust and a bonding material. Imitation marble on furniture is usually plastic. (See care instructions for plastic furniture.)

Upholstered Furniture

Upholstered furniture should be cleaned with a vacuum cleaner or whisk broom. Either method removes dust and dirt.

Look for care labels under the cushions or seats of some pieces of furniture. Read the suggestions for cleaning procedures. Recommendations may include shampooing the cloth-covered furniture.

Test a small place on the back of a chair or sofa; if the test spot fades, shrinks, or looks damaged in any way, you may wish to use a professional furniture cleaner.

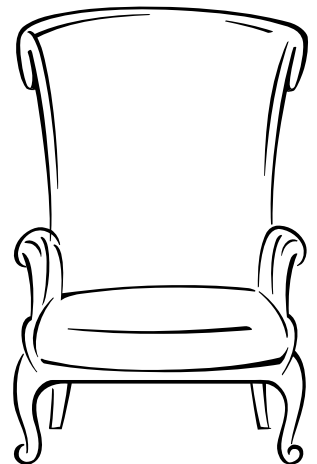

Painted Furniture

Painted furniture that is properly sealed can be cared for and protected with any wax that will give the desired amount of shine. A paste wax is recommended for the darker finishes, and a creamy liquid wax is good to use on lighter finishes that have a low luster. This applies both to the painted furniture you have purchased and to furniture you have painted yourself.

If an oil polish is applied to furniture previously cared for with wax or if a heavily oiled cloth is used, the oil will soften the wax, leaving a smeary, cloudy surface. Accumulation of a greasy film from cooking and heating fumes is another common cause of a smudged surface. The same problem can occur when furniture wax itself is incorrectly applied or polished. Some furniture care products contain cleaners and solvents that remove soil as well as the previous coat of polish when applied. Dirt and polish buildup should not be a problem if good quality products are used according to label directions.

Oil-finish Furniture

Oil-finish furniture made in the United States has usually been sealed with a lacquer by the manufacturer. These finishes often have a low luster, so a creamy liquid wax or paste wax is best for cleaning and waxing.

Solvents in some products could damage the finish. This is true of much of the oil-finished furniture in the home. For this reason it is always best to test-clean an inconspicuous area before proceeding. If the results are not satisfactory, check the manufacturer's directions or ask a reputable furniture dealer for suggestions on care and cleaning.

Preventive care is important for all furniture. Some tips for caring for wood furniture finishes are:

- Avoid placing furniture in extreme heat or direct sunlight.
- Use coasters under hot platters and/or containers for liquids.
- Avoid using plastic protectors on the wood for a prolonged period of time because they trap heat and humidity.
- Place felt pads under metal trays or ceramic accessories.
- Lift, rather than drag or pull, an object across a wood surface.

In case an accident happens, act fast. A paper towel or clean, absorbent cloth can blot away many spills. Avoid a wiping movement as this frequently spreads the problem.

Nail polish, perfume, milk, and medicines are among common spills. Some products tend to soften the finish if left too long. After blotting, rinse with a damp cloth to be certain that all of the spilled substance has been removed. Also, be sure to dry the area thoroughly with a clean, absorbent cloth. Then apply wax or polish over the entire surface, not just where the spill occurred.

Dripping candle wax can mar a finish unless promptly removed. If noticed while the wax is soft, hold an ice cube on it for a few seconds and crumble away the hardened wax. Then gently scrape the excess with the dull edge of a plastic tool or table knife. Better yet, place a heavy blotter over the wax stain and, with a warm iron, press over the stain. Using a cloth saturated with liquid polish, rub briskly with the grain of the wood until the stain disappears.

Other recommendations for removing scratches, dents, white spots, and specific stains can be obtained from how-to-care booklets.



Sharing Information with Others

The easiest way to share information with others is by demonstrating something you've learned in this project. Some title suggestions are:

- Show and Describe the Different Elements of Design
- Select an Accessory for Your Room

Try to prepare a demonstration that has one main idea or message that you wish to convey to others. Keep it simple so they have a better opportunity to recall the information for later use.

It is the policy of the Purdue University Cooperative Extension Service that all persons have equal opportunity and access to its educational programs, services, activities, and facilities without regard to race, religion, color, sex, age, national origin or ancestry, marital status, parental status, sexual orientation, disability or status as a veteran. Purdue University is an Affirmative Action institution. This material may be available in alternative formats.

