

Indiana

4-H Shooting Sports



Coordinator Handbook

Spring, 2022



Extension - 4-H Youth
Development



Indiana 4-H Youth Development

4-H is the youth education program of the Purdue Extension Service. 4-H is the only Federal Youth Serving Organization. Administered by the Secretary of Agriculture, though Land Grant universities.



Indiana 4-H Mission:

The Indiana 4-H Youth Development mission is to provide real-life educational opportunities that develop young people who will have a positive impact in their communities and the world.

Indiana 4-H Vision:

Indiana 4-H Youth Development strives to be the premier, community-based program empowering young people to reach their full potential.

Key Aspects of the 4-H Youth Development Program:

- Focus on positive youth development.
- Subject matter from the land-grant university.
- Informal programming - emphasizing experiential learning.
- Youth, parents, and families learning together.
- Use a variety of delivery methods.
- Volunteers extend our programs far beyond what staff could do!

Why offer 4-H Shooting Sports?

- To engage youth through something they are interested in
- Help youth become successful adults – positive growth and development
- Teach firearm and archery safety
- Teach responsible equipment handling and ethics
- Teach life skills
- Introduce a lifetime sport & hobby

Shooting Sports Instructor website: <https://extension.purdue.edu/4-H/volunteer/resources-and-development/shooting-sports-volunteer-resources.html>

Indiana 4-H Shooting Sports Project website: purdue.ag/4hshootingports

Author: Natalie Carroll, Extension Faculty, ncarroll@purdue.edu
Department of Agricultural Sciences Education and Communication

Reviewer: Steve McKinley, 4-H Extension Specialist, mckinles@purdue.edu
Dave Osborne, 4-H Extension Educator, osbornda@purdue.edu

Table of Contents

4-H Policy and Procedures

4-H Youth Development	5
Certification Workshop	7
Coordinator Responsibilities	8
Objectives of Indiana 4-H Shooting Sports	9
Policy Statement	10
Role of 4-H Shooting Sports Volunteers	12
Template: Indiana 4-H Shooting Sports Liability Release Statement	13
Position Statement	14
4-H Shooting Sports Policy Prohibitions	15
4-H Shooting Sports Meetings	16
4-H Youth Participants	17
Staff	17
4-H Shooting Sports Websites	19

Managing the County Program

Accident/Incident Report Form (RM 27)	21
Equipment	22
Inventory	22
Indiana 4-H Shooting Sports Inventory Worksheet	23
Insurance	27
Storage	27
Template: Verification of 4-H Shooting Sports Equipment Kept on a Volunteer's Property	29
Transportation	30
Lending/Borrowing	30
Funding/Grants	30
Purchases and Disposal	32
Template letter for purchase/transfer of firearms	33
Pistol Trap	34
Frequently Asked Questions	35
General Requirements and Suggestions	40
Managing 4-H Club Funds	41
Discipline Bars/Patches	42
Project Completion – Project Exhibition	43
Range Plans	44
Request for Certificate of Insurance	45

Running Meetings

Evaluating Shooters	47
Meeting Suggestions	53

Safety Meeting	55
The Round Robin	59
Instructor Resources	
4-H Opportunities	61
Bullying	62
Characteristics of Youth: Ages & Stages	63
Colors Training	65
Determining Eye Dominance	66
Does 4-H Make a Difference?	68
Essential Elements of 4-H	69
Experiential Learning	71
Family Involvement	73
How Do Questions Enhance Performance?	74
Meeting Activities	76
NRA & NSSF Resources	78
Non-Threatening, Hands-on Instruction	70
Participation of Fathers	80
Publications	81
Raising Responsible Youth	83
Shooters with Disabilities	84
Youth and Violence	86
The Indiana 4-H Program & Guidelines	90
Youth Resources	
Exhibit Guidelines	97
Indiana 4-H Shooting Sports manual	99
Meeting Log	100
Poster Exhibit Guidelines and Suggestions	101
Record Sheets	103
Youth Educator Responsibilities	
4-H Youth Development Extension Educator Responsibilities	106
Liability and Insurance for Volunteers	107
Starting a 4-H Shooting Sports Program	108
Glossary	110

Suggestions from an experienced 4-H Shooting Sports Certified Coordinator:

- Be flexible, especially in a time of a global pandemic!
- Work with your county 4-H Extension Educator and the office secretaries (very knowledgeable)
- Major job: keep track of the youth (who they are, interests, and how they are doing)
- Submit a financial report every year and have the finances audited every five years and whenever there is a new treasurer

Remember: you are the “glue” that holds the county 4-H Shooting Sports program together. Thank You!

4-H Youth Development

The 4-H Program is administered by the Secretary of Agriculture, though Land Grant universities (Purdue). It is the only federally-authorized youth serving organization. (Federal oversight requires that we follow policies that other youth serving organizations are not required to follow.)

4-H Utilizes

- Non-formal programming – emphasizing *Experiential Learning* (see figure)
- Volunteers extend the reach of our programs beyond what staff can do on their own!
- Youth, parents, and families learning together
- Subject matter from the land-grant university
- A variety of delivery methods
- Focus on youth development

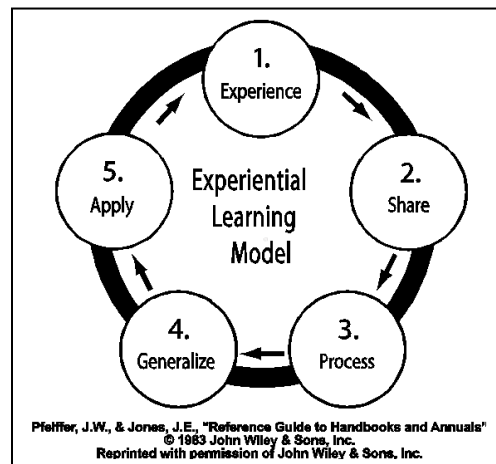

Indiana 4-H Mission:

The Indiana 4-H Youth Development mission is to provide real-life educational opportunities that develop young people who will have a positive impact in their communities and the world.

Indiana 4-H Vision:

Indiana 4-H Youth Development strives to be the premier, community-based program empowering young people to reach their full potential.

4-H Values:

Diversity – encourages creativity and promotes an exchange of ideas, tolerance, sensitivity, understanding, and mutual respect. Diversity enriches the lives of all program participants.

Education and youth involvement in the learning process, development of practical skills and abilities, and application of learned skills to other situations.

Encouraging interactions of 4-H members with peers, parents, and other caring adults.

Inclusion – 4-H programs and activities are open to all youth. Extension employees and volunteers are obligated to eliminate (and should not create) any practices that limit, deprive, or tend to deprive any youth of opportunities for membership and/or participation in the Indiana 4-H program.

Partnerships among community groups. These are essential to expand the number and improve the quality of programs, make the best use of available resources, and build community consensus.

Volunteers – the people that create programs to meet local needs, deliver quality educational programs, and develop adult and teen leadership.

Youth as Resources – Getting youth involved in selecting their own learning activities, participants in real-life learning experiences.

4-H Strategies:

1. Educate youth and adult participants through practical, hands-on, learn-by-doing methods that emphasize life skills. 4-H strives to develop life skills through the areas of competency, coping, and contributing.

These include:

<u>Competency</u>	<u>Coping</u>	<u>Contributing</u>
Acquiring knowledge	Recognizing self-worth	Applying leadership skills
Using scientific knowledge	Relating to others	Taking community action
Making career decisions	Making decisions	Volunteering
Managing resources	Solving problems	Conserving the environment
Communicating	Dealing with change	
Mastering technology		

2. Promote maximum youth participation in planning, conducting, and evaluating 4-H programs. 4-H believes that participation empowers members and makes learning meaningful for both youth and adults.
3. Identify youth-development issues and provide relevant educational programs to address these issues.
4. Increase public and private support of 4-H program with time, money, material, and commitment. 4-H must take the lead in inspiring the community to bring all available resources to bear on critical youth issues.

Certification Workshop

The 4-H Shooting Sports program is one of the few 4-H programs in Indiana that require certification of volunteers. Each county must have a coordinator and discipline instructors. To become certified, individuals must apply, and be approved, to be a 4-H volunteer in their county, attend an entire 4-H Shooting Sports certification workshop, and pass both a written test and practicum. Note that other certifications and trainings offered by other organizations may *not* be substituted for the 4-H certification workshop.

Disciplines:

Archery
Coordinator
Muzzleloading
Outdoor Skills
Pistol
Rifle
Shotgun

Workshop dates at: <https://extension.purdue.edu/4-H/volunteer/resources-and-development/shooting-sports-volunteer-resources.html>

Indiana Certification Workshop - held at **Ross Camp**

- All workshops will be held at Ross Camp in Tippecanoe County.
- Registrations are due two weeks before the workshop **IHEA**.
- IHEA will provide map and agenda via e-mail
- Note: all disciplines minimum and maximums on the number of participants
- Future Workshop Dates:
 - Spring, 2021: April 9-11, Ross Camp
 - Fall, 2021: September 10-12, Ross Camp
 - Registration: **IHEA website** (electronic Registration Form & Health Form)

Notes:

- Checks should be made payable to **IHEA Training**.
- Full payment must accompany the registration (No reservations without payment.)
- Refund policy is as follows: Full refund until the workshop deadline; one-half the amount from the deadline to 3 full days before the workshop begins; no refunds after that time.
- There will be a \$20.00 late fee assessed for registrations and/or payments received after the due date.
- A minimum number of participants is required in each discipline or the class will be cancelled.

Send Registration & payments to:

Tim Beck
E-mail: tbeck@dnr.IN.gov
I.D.N.R Law Enforcement
P.O. Box 917
Jasper, IN 47547
Phone: (812) 482-3093
Fax: (812) 482-3093

Workshop registrations are available at
<http://www.inhea.com/>



IDNR Law Enforcement and Purdue University are hosting the 2021 4-H Shooting Sports Fall Workshop at Ross Camp, West Lafayette, Indiana on September 10th through 12th. This workshop is a requirement if you want to become a certified Indiana 4-H Shooting Sports Instructor.

[Click Here To Register](#)

Coordinator Responsibilities

The 4-H Shooting Sports Coordinator is a critical component of the 4-H Shooting Sports program. They work with the County 4-H Youth Development Extension Educator to provide a quality youth program. *The coordinator is the conduit between the County Extension Educator and discipline instructors.* Everyone needs to work together to maintain excellent relations. Remember: 4-H is for **Youth**.

Assist the County 4-H Youth Extension Educator in keeping proper documentation:

- List of Certified 4-H Shooting Sports instructors
- Indiana 4-H Shooting Sports Inventory Worksheet. For all firearms and archery equipment owned by 4-H, be sure to include serial numbers, make, and model. Also account for all ammunition and other supplies, as well as items removed from the inventory. (see p. 23-26)
- A copy of each 4-H Shooting Sports Range Plan. This form must be submitted and approved for each range that is used for the 4-H Shooting Sports program. (see p. 44)
- Copy of any Requests for Certificate of Insurance (RM02). This form is used to request a copy of Purdue's liability insurance if requested by a property or equipment owner. The certificate is good for one calendar year. (see p. 45)
- Complete Purdue's Accident/Incident Report Form (RM 27), if needed. (see p. 21)
- Submit a financial report every year and have the finances reviewed/audited every five years and whenever there is a new treasurer.
- Complete all IRS filing requirements annually.

Organize and coordinate the county 4-H Shooting Sports program. This includes:

- Scheduling meetings (date, time, place; be sure to add these meetings to the county extension calendar)
- Inventorying equipment (see p. 23-26)
- Recruiting new instructors and members
- Explaining completion and exhibit requirements to youth
- Consider options for in-person and virtual programming
- Complete any necessary health safety plans for in-person opportunities

Work with county 4-H Shooting Sports team to:

- Determine needs for equipment, ranges, additional instructors, funds for training new volunteer instructors, and funding for equipment
- Assure age-appropriate training and inclusion of all 4-H members. Encourage discipline instructors to work with older youth in the program to assure that their needs and interests are being met. Older youth make excellent mentors/assistant instructors and often have great ideas and work well with the younger members
- Share news and information from the county educator and state office (opportunities for youth, etc.) with your instructor team
- Hold county Shooting Sports instructor team meeting(s) to discuss program goals, objectives, and review progress

Objectives of Indiana 4-H Shooting Sports

The 4-H Shooting Sports program strives to enable young people, their parents, and adult volunteers to become responsible, self-directed, and productive members of society. Educators, volunteers, instructors, and coaches must understand the goals and objectives of the program in order to manage or present it properly. These goals and objectives are consistent with the goals and objectives of the entire 4-H program. The program transfers knowledge, skills, and attitudes to develop human capital, using the subject matter and resources of the land-grant universities.

The specific goals and objectives of the 4-H Shooting Sports program include, but are not limited to, those listed below:

- To promote the highest standards of safety, sportsmanship, and ethical behavior, including sound decision making.
- To enhance development of self-concept, character, and personal growth through safe, educational, and socially acceptable involvement in shooting activity.
- To teach safe and responsible use of firearms and archery equipment through self-discipline and concentration.
- To complement and enhance the impact of existing safety, shooting, and hunter education programs using experiential educational methods and progressive development of skills and abilities.
- To expose youth to the broad array of vocational and lifelong hobbies related to Shooting Sports.
- To strengthen families through participation in lifelong recreational activities.
- To encourage participation in natural resources and related natural science programs by exposing participants to the content through shooting and related activities.

Note:

The Outdoor Skills discipline offers an excellent class, particularly for the younger participants. Some programs limit the shooting that these new members can do because of their age and size. The Outdoor Skills discipline is a great way of introducing them to the outdoors and the wildlife that we enjoy here in Indiana. Hunting is not the focus of this training. Looking for a way to retain your older members? This discipline gives you all the tools you need and lots of opportunities for letting older youth do the teaching.

Indiana 4-H Shooting Sports Policy Statement

*** The Following Policy Supersedes All Previous Drafts ***

2016

Preamble: *One of the goals of the Indiana 4-H Shooting Sports program is to encourage and support volunteers upon whom 4-H depends to extend its programs for the benefit of the youth of Indiana. A very important liability issue associated with volunteers is the teaching of age appropriate instruction and effective supervision. Thus the certification of 4-H Shooting Sports instructors and coordinators through state-sponsored workshops is essential to the integrity and success of the program. These workshops teach volunteers about program safety and the developmental abilities and maturity of 4-H youth. Purdue University provides liability coverage for adult volunteers while they are acting at the direction of, and within the scope of, their duties in the Indiana 4-H Shooting Sports program.*

Policy statement: The primary goal of the Indiana 4-H Shooting Sports program is to teach young people how to safely and appropriately handle firearms and archery equipment. While it is understood that many parents, choose to involve their children in this activity as a “prelude” to hunting activities, the Indiana 4-H Youth Development Program under **no circumstances** provides authority to volunteers to arrange or conduct hunting activities with (or for) 4-H members.

Certified Shooting Sports volunteers involved with the Indiana 4-H Shooting Sports Program must complete the Indiana 4-H Youth Development Application/Screening Process and participate in the State 4-H Shooting Sports Certification Workshop **prior to** participating as a volunteer with the program. All Indiana 4-H Shooting Sports Programs must have a 4-H Shooting Sports Certified Coordinator. All 4-H shooting activities must be directly supervised by Indiana 4-H Shooting Sports Certified Instructors.

If a program divides the participants into groups for concurrent shooting sessions, each group must be under the on-site supervision of an Indiana 4-H Certified Shooting Sports Instructor, teaching in **only** the discipline in which he/she holds certification. Associate instructors and other 4-H adult volunteers must be under the direct physical supervision of an Indiana 4-H Shooting Sports certified instructor while engaged in any activity which involves the use of firearms and/or archery equipment.

Tree climbing and activities involving tree stands may only be taught by Outdoor Skills discipline instructors who have received training from the state 4-H Shooting Sports team. Teaching and using firearm reloads (cartridges and shells) is prohibited in 4-H Shooting Sports educational activities. For safety reasons, cartridges and shells must be purchased from authorized manufacturers who apply industry standards in the manufacturing and loading process.

Definitions:

- **4-H Shooting Sports disciplines:** archery, outdoor skills, muzzleloading, rifle, pistol, and shotgun.
- **Indiana 4-H Shooting Sports State Coordinator:** Purdue University employee responsible for training 4-H Shooting Sports Coordinators and working with Indiana Extension Educators to provide the 4-H Shooting Sports program to youth across Indiana.
- **Indiana Hunter Education Coordinator:** Indiana Department of Natural Resources employee responsible for selecting and training Indiana State 4-H Shooting Sports Instructors; planning, coordinating and managing training workshops; and certifying Indiana 4-H Shooting Sports Instructors.
- **Indiana 4-H Shooting Sports State Instructor:** An adult volunteer or staff person who has been selected by the Indiana Department of Natural Resources, Hunter Education Coordinators, trained by the state discipline team, passed a probationary period, has joined the state instructor team, attends state instructor team meetings and provides training to county instructors.

- **Indiana 4-H Shooting Sports Certified Instructor:** An Extension Educator or adult volunteer who has county background validation and has successfully completed a course of training at an Indiana 4-H Shooting Sports Workshop (Sponsored by the State 4-H Youth Development Department and Indiana Department of Natural Resources).
- **Indiana 4-H Shooting Sports Certified Coordinator:** A 4-H Shooting Sports Program Coordinator is an Extension Educator or adult volunteer who works primarily with other volunteers to deliver the 4-H Shooting Sports program in the county. Volunteers work under the guidance of their county 4-H Youth Extension Educator.
- **Associate 4-H Shooting Sports Instructor:** An Extension Educator or adult volunteer who has locally recognized experience in the 4-H Shooting Sports program and/or youth development and proper county background validation and who has been trained at the local level by an Indiana 4-H Shooting Sports Certified Instructor in the discipline which he/she is assisting.

Indiana 4-H Shooting Sports Policy Statement

To avoid potential problems in the event of a claim, Extension office files should include a complete list of volunteers working on each activity for at least one year after the activity. In order for coverage to respond for either a staff member or a volunteer, it is imperative that potential claims be reported immediately to the local County 4-H Extension Educator.

Compliance Statements

A Shooting Sports compliance statement must be completed and filed with the State 4-H Office each time a new Extension Educator assumes responsibility in a county that conducts a Shooting Sports program. The compliance statement is an opportunity for the Educator to verify the following:

- Two or more Indiana 4-H Shooting Sports Certified Instructors must directly supervise all 4-H Shooting Sports activities. If a program divides the members into groups for concurrent shooting sessions, groups must be under the on-site supervision of an Indiana 4-H Shooting Sports Certified Instructor.
- Adult volunteers who are primarily responsible for a concurrent session which involves the use of firearms and/or archery equipment must be Indiana 4-H Shooting Sports Certified Instructors in the discipline which they are teaching.
- Associate Instructors and all remaining adult volunteers must be under the direct physical supervision of an Indiana 4-H Shooting Sports Certified Instructor while engaged in an activity which involves the use of firearms and/or archery equipment. All adult volunteers and youth engaged in the use of firearms and/or archery equipment must be advised of the basic range safety rules before shooting starts. All Shooting Sports programs must have an Indiana 4-H Shooting Sports Certified Coordinator.
- 4-H Shooting Sports instructors are certified to provide shooting instruction to youth in grades 3-12 who are enrolled in the Indiana 4-H Youth Development Program. Youth in grades 3-12 who are not enrolled in Indiana 4-H may participate in a “public shoot” if certain conditions are met. See “Role of 4-H Shooting Sports Volunteers” for additional details.

NOTE: Purdue University only extends liability coverage to certified volunteers working in their capacity as 4-H volunteers and to 4-H members (grades 3-12).

Range Plans

Each county Shooting Sports program shall keep on file with the State 4-H Office a range plan for EACH range utilized for local Shooting Sports workshops and activities. When new ranges are utilized or the configuration of a range is changed, the range plans must be updated. These range

plans are critical in terms of liability issues and Purdue University's insurance coverage and protection for the volunteers involved with the program.

Role of 4-H Shooting Sports Volunteers

- 4-H Shooting Sports Instructors are certified to provide shooting instruction to youth in grades 3-12 who are enrolled in the Indiana 4-H Youth Development Program.
- 4-H Shooting Sports Instructors provide education on the safe and responsible handling of firearms and archery equipment for 4-H members.
- Individuals may choose to support programs such as Hunter's Education or organizations such as the Friends of the NRA. If they do, they would be doing so as individuals beyond and separate from their volunteer duties within the 4-H Shooting Sports program.
- A public shoot or exhibition for youth in grades 3-12 who are NOT enrolled in the Indiana 4-H Youth Development Program is allowable as an officially recognized 4-H/Purdue University activity, as long as **ALL** of the following conditions are met:
 1. An approved range plan must be on file with Purdue University, including a description of how the public will be kept at a safe distance. The 4-H Youth Development Extension Educator should submit this plan to the State 4-H Shooting Sports Coordinator for review.
 2. At least two (2) adult 4-H Shooting Sports Instructors certified in the discipline being offered must be present before the first youth arrives and after the last youth leaves.
 3. Only youth in grades 3-12 may participate. Opportunities for youth younger than grade 3 and for adults are not permissible.
 4. A parent/guardian for each non-4-H Youth participant must have signed a Purdue 4-H Youth Development Liability Release Statement before the youth may participate (see template including required language on the next page).
 5. All standard 4-H Shooting Sports safety procedures and basic range safety rules must be followed.
 6. A Special Activities Policy must be purchased from American Income Life Insurance to cover those youth who are not enrolled as 4-H members.
- NOTE: Purdue University extends liability coverage to certified volunteers working in their capacity as 4-H volunteers and to 4-H members (grades 3-12).

TEMPLATE

Indiana 4-H Shooting Sports Liability Release Statement

(Provided to youth not currently enrolled in the Indiana 4-H Youth Development Program)

We are glad that you are interested in participating in our 4-H Shooting Sports activity! As a condition of being able to participate, a parent or guardian needs to read and sign the following liability release statement.

I certify that my child is within the 3rd through 12th grade range that is eligible to participate.

I understand that participating in 4-H activities can involve certain risks to my child. Those risks may include injury or harm, including, but not limited to, bodily injury, disability, exposure to COVID-19 and other viruses and or illnesses, and death. During virtual 4-H activities, I understand that program staff are not providing supervision for my child during the online program, and the Released Parties do not have control over the information available through the internet or other electronic data sources beyond that which is a part of the 4-H activity. On behalf of my child, I fully assume the inherent risks associated with my child participating in 4-H activities and assert that my child has chosen to participate in this program with my express approval. I hereby release and discharge Purdue University, The Trustees of Purdue University, the _____ County Commissioners, the _____ County Cooperative Extension Service, and each of their trustees, officers, appointees, agents, employees, and volunteers ("Released Parties") from all claims which my child or I might have for any injury or harm to my child, arising out of my child's participation in any activity related to the 4-H program, even if such injury or harm is caused by the negligence or fault of any of the Released Parties. I do not, however, release these individuals and entities from liability for intentional, willful or wanton acts and this release shall not be construed to include such acts.

Name of Youth Participant

Signature of Parent/Legal Guardian

Date



Position Statement

4-H programming encourages youth to:

- experience new activities;
- share the results of their learning;
- process the experience by analyzing and reflecting on it;
- generalize the experience by connecting it to real-world situations; and
- apply what was learned to different situations.

Youth involved in 4-H programming develop practical skills that help them to develop into capable, competent, responsible adults. A large support network of Extension educators, campus specialists, parents, and nearly 12,000 volunteers makes Indiana 4-H one of the largest youth programs in the state.

4-H programs offer a wide range of curriculum choices so youth are able to explore new areas. In all 4-H programs, caring adults provide both technical expertise and social contact, because part of positive youth development is based on positive relationships. Since participation in 4-H programming is voluntary, it is important to offer a wide variety of experiences so many avenues can be explored.

Why does Indiana 4-H have a Shooting Sports program?

- The Shooting Sports program teaches self-confidence, personal discipline, responsibility, teamwork, and sportsmanship.
- The Shooting Sports program appeals to youth that may not be interested in other 4-H offerings, especially males (over 65% of Shooting Sports participants are males).
- The 4-H Shooting Sports program teaches safe and ethical use of firearms.

Isn't it dangerous to teach kids about guns?

- Our society allows its citizens to possess firearms. Therefore, citizens should be provided adequate training to ensure safe, ethical, and responsible use of firearms.
- Having and using firearms does not lead to violence. Violence is a symptom of larger societal issues. The Commission for the Prevention of Youth Violence listed the following risk factors in its report: alcohol and other drugs, child maltreatment (physical and emotional), gang involvement, gun availability, media violence, violence among intimates and peers. *Youth and Violence, Medicine, Nursing, and Public Health: Connecting the Dots to Prevent Violence*: (American Medical Association, December 2000).

The Indiana 4-H Shooting Sports program involves more than 5,500 youth each year. Programs are provided by trained and certified Shooting Sports instructors. The certification workshop teaches volunteers about youth development as well as safe and ethical use of firearms.

4-H Shooting Sports Policy Prohibitions

The following are not permitting within the 4-H Shooting Sports program:

- Arranging for or conducting hunting activities is NOT a part of Indiana 4-H Shooting Sports.
- Simulated combat sports are PROHIBITED in 4-H Shooting Sports, including, but not limited to: pointing any type of gun or firearm at any person or any humanoid-shaped target. This would include the use of paint ball guns, air-soft guns, laser guns, laser paint-ball, archery tag bows and arrows, or sighting devices. Note: these types of guns/firearms are permissible in 4-H Shooting Sports *only* if they are utilized in a controlled atmosphere where the static target is not a person or humanoid-shaped target.
- The following types of reactive targets are prohibited in 4-H Shooting Sports: those that make use of or are composed of (1) live ammunition, (2) explosives, chemicals or flammable substances, or (3) pressurized containers.
- Tree Climbing and Tree Stands - Tree climbing and activities involving tree stands must be taught by Outdoor Skills discipline instructors who have received training from the State 4-H Shooting Sports team.
- Factory manufactured ammunition - Cartridges and shells must be purchased from authorized manufacturers who apply industry standards in the manufacturing and loading process.
- Teaching and using firearm reloads (cartridges and shells) is prohibited in 4-H Shooting Sports educational activities.
- Modifications made to firearms can be made only if they:
 - Enhance the youth's shooting experience;
 - Are inspected by a qualified individual; and
 - Are documented regarding what was altered, when, and by whom and included in the 4-H Shooting Sports county records.

Examples: shortening of the stock of a shotgun to provide an appropriate fit for a youth member; adding a recoil pad to a firearm.

4-H Shooting Sports Meetings

The 4-H Shooting Sports program is successful because of the dedicated, Shooting Sports certified volunteers. Volunteers work hard to achieve the Shooting Sports program goals and to maintain the highest standards of safety. When scheduling meetings, please make every effort to work through scheduling conflicts that some youth will have, to be as inclusive as possible. We know that this can be difficult for volunteers who give so much time to the program and try hard to schedule meetings at a time that works best for all. Remember, however, that as difficult as it is for you to schedule time, it may be even more difficult for the 4-H youth, because they must coordinate their schedule with both the meeting time and their parents' schedules.

Meetings

Per federal guidelines, volunteers and Extension Educators may not require youth to attend 4-H club meetings. There is one exception to this policy: if the County 4-H Youth Extension Educator and county Shooting Sports instructors feel it is necessary, one safety meeting *may* be required of 4-H youth enrolled in Shooting Sports. **Review of safety guidelines is required at all range meetings, whether or not a special safety meeting is held.** (See the 4-H Shooting Sports Policy Statement, p. 11).

Safety meeting requirements:

- An educational lesson plan for the meeting must be approved by the 4-H Extension Educator and on file in the county extension office prior to conducting the safety meeting.
- The lesson plan should list the safety topics that will be taught in the required meeting and estimated time to be spent on each topic. An educationally-appropriate length for a safety meeting is no longer than 60-90 minutes.
- An example agenda is given at <https://extension.purdue.edu/4-H/volunteer/resources-and-development/shooting-sports-volunteer-resources.html> (See also p. 55-58 of this handbook).
- If a safety meeting is required, it should be offered at multiple times and possibly in multiple formats (e.g., face-to-face, recording, paper) to provide opportunities for all 4-H members to receive this information. The required safety meeting can be held at the shooting range or at a separate meeting before range shooting begins.

Hunter Education (IDNR program)

Many 4-H Shooting Sports instructor teams choose to offer the IDNR Hunter Education (HE) course to 4-H members. This course gives an overview of firearms and hunting and includes some safety information. Note, however, that **while the Hunter Education course may be recommended, it may not be required in 4-H Shooting Sports.** The course may be offered by IDNR in person or online via the IDNR website for students who are at least 12 years of age. If a 4-H Shooting Sports member voluntarily completes the IDNR HE program, the local 4-H Shooting Sports program may accept proof of HE completion instead of asking the member to also attend and complete the required 4-H Shooting Sports safety meeting.

4-H Youth Participants

- 4-H Shooting Sports is open to all students in grades 3-12 in accordance with Purdue University's non-discrimination policy.
- Students younger than grade 3 are not eligible for any aspect of 4-H Shooting Sports programs, as these are not age appropriate activities.
- Instructors are encouraged to identify strategies to accommodate youth members and adult volunteers with disabilities.
- A 4-H Shooting Sports Instructor has the right to refuse any participant from the shooting sports activity in the interest of safety for the participant and others in the program.
- County 4-H Shooting Sports programs may choose to limit the disciplines they offer due to availability of local resources.

Staff

Professional Staff

Professional Staff consists of the **4-H Youth Extension Educator** who is responsible for providing local leadership in the county and program coordination with assistance from other county Extension staff and state staff. The **State Coordinator** is a member of the State 4-H staff at Purdue University with responsibilities including the coordination of the Indiana 4-H Shooting Sports program.

4-H Youth Extension Educator Responsibilities

- Provide overall guidance and coordination of the county 4-H Program, including 4-H Shooting Sports.
- Work with the State 4-H Office as needed.
- Complete Volunteer screening, references, and other paperwork.
- Send potential Shooting Sports instructors to certification workshops.
- Submit required compliance statement, equipment/supply inventory, and range plans to the State 4-H Office.
- Prepare requests for Certificate of Insurance.
- Work with the county 4-H Shooting Sports coordinator and team, serving as the primary point of contact for 4-H Volunteers who have program questions or concerns.

Volunteers

All 4-H programs depend on the dedication, time given, and involvement of volunteers. **Volunteers are the core of any county 4-H program.** Volunteer 4-H staff includes 4-H program and project volunteers, members of county Extension boards, county 4-H councils, county 4-H fair boards, and numerous other special committees that provide support to the

county program. 4-H programs could not survive without volunteers who organize, manage, and bring the programs and projects to Indiana youth. The 4-H Shooting Sports program has an additional requirement because of the expertise required and liability issues that accompany the use of archery and firearm equipment.

Certification is required of discipline instructors and county 4-H Shooting Sports program coordinators. The certified instructors are the core of a county program. Each certified instructor is placed in a specific role for the County 4-H Shooting Sports program at the discretion of the County 4-H Youth Development Extension Educator. Other adult 4-H Volunteers can help with the Shooting Sports program as Associate instructors, under the guidance of a certified 4-H Shooting Sports instructor.

Individuals may begin the process to become a 4-H Volunteer and Certified Shooting Sports Instructor once they have completed their 4-H eligibility.

- Each individual has different skills, abilities, and maturity level. Some 18-year-old adults may be ready to serve as a volunteer immediately; some may not. The 4-H Youth Development Extension Educator, in consultation with the 4-H Shooting Sports Coordinator, will determine the suitability of an individual for a volunteer role with the 4-H Shooting Sports program.
- It is recommended that a new volunteer (regardless of age) start as an Associate Instructor prior to assuming a more significant volunteer leadership role.

4-H Shooting Sports Coordinator

The 4-H Shooting Sports Coordinator is a critical component of the 4-H Shooting Sports program. The Coordinator fills a vital function as the liaison between the professional and volunteer staff that provide this program to youth.

4-H Shooting Sports Instructor Website

<https://extension.purdue.edu/4-H/volunteer/resources-and-development/shooting-sports-volunteer-resources.html>

SHOOTING SPORTS RESOURCES FOR INDIANA 4-H INSTRUCTORS AND EDUCATORS

The objective of the 4-H Shooting Sports Education program is to teach safe use of archery and firearm equipment while helping youth grow and develop into happy, healthy, and contributing adults.

ADDITIONAL OBJECTIVES AND GOALS



Thanks to our many program supporters: Indiana Department of Natural Resources Law Enforcement; Friends of the NRA; National Wild Turkey Federation; and many conservation clubs and councils across Indiana!

Find out about the 4-H Shooting Sports program in your (Indiana) county by contacting your local Cooperative Extension Office via the listing at: **county office.**

Coordinators Recertification Training, Next session: September 15, 2021, 6:30 - 8 p.m.

- Indiana 4-H Shooting Sports Coordinator **Handbook Fall 2021**
- **4-H Shooting Sports Inventory Worksheet**
- **Template: Verification of 4-H Shooting Sports Equipment Kept on a 4-H Volunteer's Property**
- **Memo re: 4-H Shooting Sports Programs**
- **Shooting Sports Range Plan Form**
- **Accident/Incident Report Form, RM 27**
- Recertification Powerpoint slides **PPT, 2021**
- Watch the September 15, 2021 meeting recording

The image shows a YouTube video player with a play button in the center. The video title is "4-H Shooting Sports Objectives" and the channel name is "2021 4-H Shooting Sports Coordinator ...". The video content displays three bullet points:

- To promote the highest standards of safety, sportsmanship, and ethical behavior, including sound decision making.
- To enhance development of self-concept, character, and personal growth through safe, educational, and socially acceptable involvement in shooting activity.
- To teach safe and responsible use of firearms and archery equipment, self-discipline, and concentration.

At the bottom of the player, it says "Watch on YouTube" and "Handbook, pg. 9".

Indiana Certification Workshop - held at **Ross Camp**

- All workshops will be held at Ross Camp in Tippecanoe County.
- Registrations are due **two weeks** before the workshop **IHEA**.
- IHEA will provide map and agenda via e-mail
- Note: all disciplines have a minimum and maximum number of participants.
- Future Workshop Dates:

4-H Shooting Sports Member Web page
purdue.ag/4hshootingports

PURDUE UNIVERSITY | Extension - 4-H Youth Development

CONTACT US ▾ ABOUT ▾ GET INVOLVED ▾ PROJECTS ▾ VOLUNTEER ▾ RESOURCES ▾ GIVING ▾

Home > 4-H Home > 4-H Projects > 4-h-project-shooting-sports

Shooting Sports

The 4-H shooting sports project teaches safe operation of firearms and archery equipment.

4-H EXTENSION NEWS AND ARTICLES HEALTH & HUMAN SCIENCES COMMUNITY DEVELOPMENT

PROJECT RESOURCES

- PUBLICATIONS +
- SCORE CARDS +
- RECORD SHEETS +
- EXHIBIT REQUIREMENTS +
- OTHER +

Managing the County Program

Accident/Incident Report Form (RM 27)

www.purdue.edu/business/risk_mgmt/pdf/rm27.pdf

When an accident or injury that requires medical or dental attention occurs at a 4-H event, it is imperative that you immediately contact your 4-H Youth Extension Educator who will complete the Risk Management Form (RM27, see below). The form must be completed in its entirety including the section on witnesses to the accident (with information from someone who witnessed the event or has knowledge of it).

Coordinators can expedite this process by having copies on hand at all range events (or giving them to the lead instructor in each discipline) so they can complete as much of the form as possible when the injury occurs. Download a new form each year, in case it has been updated.

The 4-H Youth Extension Educator must submit this form to Purdue's Risk Management Office with copies to the State 4-H Office, Area Director, and County Extension Director.

If an accident happens...

- A homeowner/landowner's insurance is primary. It will take effect before any coverage provided by Purdue University.
- Purdue provides coverage for bodily injury or personal injury to third parties.
- This includes damage to their property when such injury is the result of Purdue's negligent act.

RM 27

**PURDUE UNIVERSITY
COOPERATIVE EXTENSION / 4-H
ACCIDENT/INCIDENT REPORT FORM**

(Please Print Legibly)

This form is to be completed whenever a 4-H member, volunteer, or spectator who is participating in or attending an approved CES event/activity receives an injury which requires medical or dental attention.

Forward completed form to:

Tiffany Utermark Office of Risk Management 2550 Northwestern Ave., Suite 1100 West Lafayette, IN 47906	Erica Downey Office of Vice President for Ethics and Compliance 155 S. Grant St. West Lafayette, IN 47907
PHONE: (765) 494-6134 FAX: (765) 496-1338 EMAIL: utermark@purdue.edu	PHONE: (765) 496-6020 EMAIL: youthprotection@purdue.edu

I. INJURED PARTY

Name: _____ Age: _____

Address: _____

4-H Club Member in _____ County

If not 4-H Club Member, please explain person's participation in/attendance at the event/activity.

II. DESCRIPTION OF ACCIDENT/INCIDENT

Date: _____ Time: _____ a.m. _____ p.m.

Location: _____

Address: _____

Event/Activity: _____

Equipment

Inventory of Equipment

Both the Coordinator and Extension Office should keep an inventory of all the equipment that the 4-H Shooting Sports club or 4-H Council owns. Use the “Indiana 4-H Shooting Sports Inventory Worksheet” to record all of the requested information, including: firearm make, model, serial number, when purchased, who purchased, who has possession. A copy of this worksheet is on the following pages. Annually, this inventory should be submitted to the County Extension Office by October 1. Update the inventory any time a change is made and resubmit it to the Extension Office. An electronic copy of a fillable inventory sheet is available on the 4-H Shooting Sports Instructor webpage (<https://extension.purdue.edu/4-H/volunteer/resources-and-development/shooting-sports-volunteer-resources.html>).

If equipment is stored at a volunteer’s home, provide a signed letter attached to the equipment inventory indicating the name and address of the volunteer who has possession of the equipment between meetings. The letter should also indicate that the volunteer’s insurance company is aware that the firearms are stored at his/her property. See the following page for a template letter: “Verification of 4-H Shooting Sports Equipment Kept on a 4-H Volunteer’s Property”.

The inventory and letter will help you keep track of the equipment (sometimes of significant value) and clarify that it belongs to the 4-H Shooting Sports program.

Recommendation:

Keep pictures of each gun in your files – one showing the entire firearm and one with a close-up of the serial number.

Indiana 4-H Shooting Sports Inventory Worksheet

This worksheet is to be completed annually, and updated any time a change is made to the inventory. Submit the completed annual inventory by October 1 to the Purdue Extension County 4-H Extension Educator and 4-H Shooting Sports Coordinator. Separate worksheets may be completed for each discipline.

Name of County	Date Inventory Completed	Name of Person Completing Inventory	Role of Person Completing Inventory

I, _____, certify that the information contained in this inventory worksheet is accurate to the best of my
 (printed name) knowledge as of _____.
 (Date)

Signature _____
 (person completing inventory)

I (We) have reviewed the information contained in this inventory with the person listed above and agree that it is accurate to the best of my (our) knowledge.

Signature _____ Date _____ Signature _____ Date _____
 (County 4-H Shooting Sports Coordinator) (County 4-H Extension Educator)

Disciplines included in this inventory worksheet (check all that apply)

- Archery
- Muzzleloader (Black Powder)
- Outdoor Skills
- Pistol
- Rifle
- Shotgun

4-H Shooting Sports Firearm and Archery Equipment Inventory

Item #	Make	Model and Caliber/Gauge	Serial Number	Purchase date	Purchaser	Where purchased/obtained	Purchase price	Account, Check No. Authorization
<i>Example</i>			<i>14-13-046834-15</i>					
1								
2								
3								
4								
5								
6								
7								
8								
9								
10								
11								
12								
13								
14								
15								

(add lines as needed)

	All receipts for firearms and equipment are on file at: <i>(Include the purchaser's name and the serial numbers on the receipt.)</i>	
	Yes	No
4-H Shooting Sports Coordinator		
Purdue County Extension Office		
Other (please describe)		

4-H Shooting Sports Firearm and Archery Equipment Storage and Insurance

Item # (from list above)	Physical address where item is stored	Method of storage for item	Who has access to the item?	How is the item insured? (include policy number and name of insurance company)	Does the property owner's insurance company know this item is stored at this location?
<i>Example</i>	<i>4444 Clover Lane</i>	<i>Locked gun safe</i>	<i>4-H Shooting Sports Instructor</i>	<i>4-H Shooting Sports Club policy through Farm Bureau, #SS4H</i>	<i>Yes</i>
1					
2					
3					
4					
5					
6					
7					
8					
9					
10					

(add lines as needed)

Supplies, Expendables Inventory

(Note: only include items with an individual value of \$25 or more)

Item description	Purchase price	Quantity	Total Value	Instructor/Discipline	Location of inventory

(add lines as needed)

Equipment removed from inventory*

Make	Model and Caliber/Gauge	Serial Number	Date removed from inventory	Reason

* *NOTE: There are three choices for disposing of firearms:*

- 1. turn them in to the local law enforcement office for proper disposal*
- 2. trade them in when a new firearm is purchased*
- 3. turn them over to Indiana Hunter Education Association (IHEA) for a 5-year storage hold*

Insurance for Equipment

Insurance coverage for the loss or damage of 4-H Shooting Sports equipment is the responsibility of the county 4-H program. Purdue University does NOT provide this coverage. Insurance coverage is purchased locally. Potentially a rider on an existing property insurance coverage policy, owned by a 4-H Council or a 4-H Fair Board, can be purchased. An insurance audit is recommended every 2-3 years to be sure coverage is adequate.

Storage of Equipment

Regardless of storage location chosen, firearms should be kept unloaded in a locked safe in a secure location. Firearms should be stored separately from ammunition.

Access to the 4-H Shooting Sports equipment is limited to the 4-H Shooting Sports Coordinator, certified instructors for the 4-H Shooting Sports discipline, and the 4-H Extension Educator. These individuals may be provided with a key and/or combination to the locked equipment by virtue of their volunteer/staff status.

The 4-H Extension Educator needs to know where the equipment is being stored. The 4-H Extension Educator is not expected to handle equipment on behalf of the volunteers.

In addition to security considerations mentioned previously, convenience and accessibility should also be considered. Viable options for storing equipment may include: fairgrounds, ranges used for live fire, local law enforcement, extension offices, volunteer homes.

The following are the storage practices recommended by the National 4-H Shooting Sports Program Leaders Working Group:

Storage of Firearms & Muzzleloading Equipment

1. All Firearms will be stored unloaded in a commercial firearm safe with an open bolt or open bore indicator when not in use.
2. All gun safes should be secured in a locked storage area, following local statutory requirements, if applicable. If no local laws apply, suitable locations include local law enforcement department firearm storage, storage closet or room with limited access, etc.
3. Keys and combinations should be available only to certified instructors, county coordinators, and state coordinators. Extension staff responsible for the 4-H Shooting Sports program in the county/state should also have access to all program equipment.

Storage of Air Guns

1. Air guns will be stored in gun cases that can be locked and stored in a storage room accessible only to instructors, county coordinator and state coordinator.
2. Keys to the storage area should only be available to instructors, county coordinator and state coordinator. Extension staff responsible for the 4-H Shooting Sports program in the county/state should also have access to all program equipment.

Storage of Archery Equipment

1. Archery equipment will be stored in a locked closet or room accessible only to instructors, county coordinator or state coordinator.

2. Doors should be double locked, and a key should only be available to instructors, county coordinator and state coordinator. Extension staff responsible for the 4-H Shooting Sports program in the county/state should also have access to all program equipment.

Storage of Ammunition

1. All ammunition, shotgun shells, rifle shells, pistol shells, powder, caps, BB's and pellets will be stored separate from the guns which use them. Access to the ammunition should have access limited to the instructors, county coordinator or state coordinator. Extension staff responsible for the 4-H Shooting Sports program in the county/state should also have access to all program equipment.
2. Ammunition should be stored in a closet or room where there are at least two separate locks on the door.

If an approved 4-H Shooting Sports Volunteer keeps equipment at their home, an up-to-date letter needs to be on file. A template letter has been developed to inform Purdue Extension and Indiana 4-H of equipment, supplies, etc. belonging to the 4-H Shooting Sports program that is housed in a 4-H Volunteer's home (see template on p. 29). The letter details the specifics of the items that are in the volunteer's possession and verification that the volunteer's insurance company knows these items are kept on the volunteer's property. This letter should be updated at least annually, and any time there is a change in the list of items stored on the volunteer's property.

TEMPLATE: Verification of 4-H Shooting Sports Equipment Kept on a 4-H Volunteer's Property

Purpose of this letter: to inform Purdue Extension and Indiana 4-H of equipment, supplies, etc. belonging to the 4-H Shooting Sports program that is housed in a 4-H Volunteer's home. The letter details the specifics of the items that are in the volunteer's possession and verification that the volunteer's insurance company knows these items are kept on the volunteer's property. This letter should be updated at least annually, and any time there is a change in the list of items stored on the volunteer's property.

DATE

To Whom It May Concern,

I, NAME OF VOLUNTEER, of ADDRESS, CITY, STATE, ZIP, have possession of the following equipment for the 4-H Shooting Sports program in NAME County:

(ADD/DELETE LINES AS NEEDED)

	Type of equipment	Serial Number	Description/Quantity
1.			
2.			
3.			
4.			
5.			
6.			

My homeowner's insurance company, NAME OF INSURANCE COMPANY, is aware that the 4-H Shooting Sports items are stored on my property. Should there be a loss or theft of the 4-H Shooting Sports items stored on my property, my homeowner's insurance policy would potentially be responsible for covering the loss.

Sincerely,

NAME

4-H Shooting Sports Volunteer Instructor

Transportation of Equipment

- All applicable local, state and federal laws are to be followed when transporting firearms, ammunition and other 4-H Shooting Sports program equipment and supplies. Only licensed individuals age 18 or older are permitted to drive vehicles transporting 4-H Shooting Sports equipment.
- When transporting firearms, air guns, ammunition and muzzleloading guns, the transporter should have the guns in locked hard cases with gun locks on each gun (either a trigger style gun lock or a cable style gun lock).
- Equipment should be transported in such a way that the equipment cannot be seen from outside the vehicle. Some examples of concealment include transporting in the vehicle's trunk, in a locked trailer, beneath a pick-up truck bed topper, etc. The vehicle should not be left unattended when equipment is being transported.

Lending/borrowing equipment

- Is permissible only with other Indiana 4-H entities/clubs. Equipment should only be used under supervision of approved 4-H Volunteer/Instructors.
- Be sure that both groups have insurance coverage for equipment.
- Maintain inventory location.
- Develop a written agreement to identify how to replace lost/damaged equipment.

Funding of Equipment

Equipment for the 4-H Shooting Sports program is expensive. Coordinators can sometimes find savings by asking at a local big box/discount store. You may request discounts and donations locally only. Requests to companies (other than at the local outlet) must come from the State 4-H Office.

A list of sources for equipment and other resources is available at the Indiana 4-H Shooting Sports website (<https://extension.purdue.edu/4-H/volunteer/resources-and-development/shooting-sports-volunteer-resources.html>), click on the link to "Equipment" and then "Resources, training programs, and equipment manufacturers". This will open a Word file, '4-H Shooting Sports Coordinators Resource List'.

Grants

Obtaining grants and funding from supporting groups can help your county program grow and keep costs to youth down. Gifts/donations [\$, guns ("item"), targets, ammunition] may be accepted. A thank you to the entity who made the donation should come from the Extension Office. Including notes/cards from youth is appreciated. Gifts to clubs do not need to come to campus. However, if anyone writes a grant that commits Extension staff time to do planning and/or delivery, it **MUST** come through campus. Applications for support must go through the Purdue Business Office and this takes time. Talk with your county 4-H Youth Development Extension Educator as soon as you hear about a grant or to get ideas about possible grants.

Equipment suggestions from State Instructors

Eye and Ear protection

1. Adequate eye protection (shooting glasses, safety glasses or safety goggles, or hardened prescription glasses) is required for all 4-H Shooting Sports participants during live fire events. Coaches or spectators on or near firing lines are subject to the same requirements.
2. Adequate ear protection is required for all 4-H Shooting Sports participants during live fire events. Where electronic hearing protection is used, it may not include radio or similar broadcasts as background noise, since that could interfere with range commands. Coaches or spectators on or near firing lines are subject to the same requirements.
3. Use an old suitcase (with a handle and rollers) to store eye and ear protection. Old socks can keep eye protection from getting scratched.
4. Purchase eye and ear protection for each participant and keep in a “baggie” with the 4-H member’s name so they have it to use each time. They get to keep it at the end of the year. You can include the costs in their dues or find a sponsor to cover the expense.

Footwear

Any participant while on the shooting line or shooting in any shooting event is required to wear shoes that completely cover their feet. Examples of footwear that are not acceptable include, but not limited to: sandals, clogs, crocs, flip-flops, and bare feet.

Rifle

Question - My son will be participating in the .22 Rifle Shooting Sports this year. It is his first time to do this event and he is a fifth grader. We start our classes next week. My question is, “is there a recommended gun?” I would like to start shopping around, but do not want to get him something that is not appropriate for the project.

Answer – A bolt action single shot. Marlin and Henry make some nice ones in the youth size. I would recommend that if he is a first time shooter and a small fellow he should go with the smaller model.

Shotgun

Question – What shotgun do you recommend?

Answer – The type of firearms that we recommend are semi-automatic 20 gauge youth model shotguns. 20 gauges offer the ideal blend: ease of use and overall chance of success. The semi-auto absorbs much of the recoil due to the action using the gas that is produced when fired to operate the action. The 20 gauge offers the advantage of more pellets in each shell than a 28ga or 410, therefore giving the youthful shooter a better chance of hitting the target. The .410 has less shot which makes it more difficult for youth to hit the target, and the 12 gauge is usually too heavy and has too much recoil for continual shooting by youth. As far as brand, we use the Remington 11-87 youth model as well as the 1100 youth models. They make youth models pump-action which will have more felt recoil as well as youth model over-unders which has more felt recoil.

CO₂ & CA information

The NRA has developed safety posters addressing Carbon Dioxide (CO₂) and Compressed Air (CA) Usage. CO₂ and CA Air Rifles & Air Pistols are used in many 4-H Shooting

Programs. These posters are designed to promote safe handling of these pressurized tanks. The posters can be ordered at: <https://materials.nrahq.org/training-materials.html>

Equipment Purchases and Disposal

Purchases:

When a 4-H Club or Council wishes to purchase a firearm (rifles, pistols & shotguns) for use in their 4-H Shooting Sports Program, follow these steps. These guidelines do not apply to archery equipment or muzzleloaders.

1. The county 4-H Extension Educator must write a memo on Extension letterhead (the name and address is required) stating that the firearm(s) is being acquired for the use of the 4-H Shooting Sports program and will be the property of that business entity. For example:

“*Ms. ShootingSports* is purchasing the following firearms:

- a. Pistol1, specs...
- b. Rifle2, specs...

solely for the use of the 4-H Shooting Sports program. These firearms will be the property of the X (enter county name) County 4-H Shooting Sports program.” (See letter template on the following page.)

2. The representative purchasing the firearms (*Ms. ShootingSports*) must complete the required Firearms Transaction Record from the Bureau of Alcohol, Tobacco, and Firearms (Form 4473) using their name, address and personal identification number. This form is provided by the seller and allows individuals to make such a purchase under the *Instructions to Transferee (buyer)*.
3. The sales receipt must include the following information: the firearm is being sold to the 4-H Shooting Sports program in X county, serial number, and name of the person who purchased the firearm for the program (*Ms. ShootingSports*).

<p><u>Pertinent Text from the Bureau of Alcohol, Tobacco, Firearms and Explosives (ATF) Form 4473: Firearms Transaction Record</u></p>
--

<p>Instructions to Transferee (buyer), #2. When the transferee (buyer) of a firearm(s) is a corporation, company, association, partnership, or other such business entity, an officer authorized to act on behalf of the business <u>must complete and sign Section A</u> of the form and <u>attach a written statement</u>, executed under penalties of perjury, stating:</p>
--

- | |
|---|
| <p>A) that the firearm(s) is being acquired for the use of and will be the property of that business entity, and</p> <p>B) the name and address of that business entity</p> |
|---|

Disposal:

When a 4-H Club or 4-H Council wishes to dispose of a firearm (rifles/ pistols/ shotguns):

- Unusable guns should be turned into the local police or sheriff departments for proper disposal.
- If a firearm is no longer useful to the 4-H Shooting Sports program, it may be sold or traded for fair market value, as long as the sales receipt includes: the name of the new owner, a note that it was sold/traded from the 4-H Shooting Sports program in X County, the serial number, and name of the person who purchased/traded the firearm). The objective here is to clarify ownership (for liability reasons). It must be clear that the club no longer owns the item if anything unfortunate happens.
- If a club is temporarily suspended, contact Indiana Hunter Ed Association for storage options.

Transfer:

When a 4-H Club or Council wishes to transfer ownership of a firearm (rifles/ pistols/ shotguns) from an individual to the 4-H program, the following procedure should be used. If firearms were previously obtained for the 4-H Shooting Sports club (using club \$\$) under an individual's name, take a letter from the 4-H Office (as described above) and resubmit the BATF Form 4473 with the letter to assure that ownership is the 4-H Club. This will show proper ownership and protect the original buyer.

TEMPLATE for purchase/transfer of Firearms (rifles, pistols, & shotguns) for 4-H Shooting Sports

(PRINT THIS LETTER ON COUNTY EXTENSION OFFICE LETTERHEAD)

To whom it may concern,

NAME OF VOLUNTEER, 4-H Shooting Sports Coordinator for NAME County, is acquiring the following firearm for use by the NAME County 4-H Shooting Sports Club, solely for the use of the 4-H Shooting Sports project. This firearm will be the property of the NAME County 4-H Shooting Sports program.

The specifications of this firearm include:

- Type of firearm (make, model, etc.)
- Serial Number

Please provide a receipt for the firearms, including the following information:

- The firearm is being sold to the 4-H Shooting Sports program in NAME County
- Serial Number
- Name of person who purchased the firearm for the program.

Thank you for your help in supporting the education of young people regarding firearm safety and the NAME County 4-H Shooting Sports Program. If you have further questions, please contact me.

Sincerely,

NAME
NAME County 4-H Extension Educator

Contact Information

Pistol Trap

Indoor pistol trap for swing stops – courtesy state pistol instructor, Brandon Adomatis

Materials

- 2" thick rigid foam (2 swing stops can be made from a 4'x8' sheet)
- Lock Tight Power Grab (or like) Foam board adhesive
- clamps



Instructions

1. Cut the rigid foam into five pieces using the following dimensions:
 - a. Note: a table saw works best
 - b. Top & bottom (cut 2): 25" x 16"
 - Cut the right side angle so the front is 22" and the back is 25" (see figure)
 - c. Back: 25" x 20"
 - Cut a hole (diameter: 4-6") centered about 10" from the left hand side and 13" high
 - d. Left side: 16" x 16"
 - e. Right side: 16" x 16.5"
 - Cut a 7° angle on the end (16" – side that will attach to the back)
2. Caulk both ends of the 16" x 16" (left) side to top and bottom
 - Use clamps to hold in place until adhesive dries
3. Caulk the 16.5" sides on the square ends (not the angled end)
 - a. Angles should match angle of the top and bottom
 - b. Use clamps to hold in place until adhesive dries
4. Attach the back (25" x 20") side of the Swing Stop with duct tape (so it can be removed for outdoor shooting)
5. Caulk inside seams of Swing Stop to increase stability

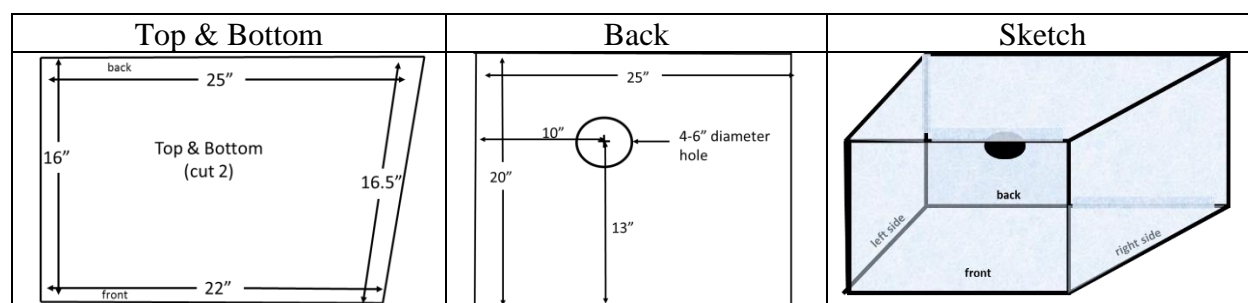

Rigid foam can also be used on traps to reduce the chance of pellet bounce back (see figure).



Frequently Asked Questions & Answers

Required meetings

Q – Can we require 4-H members to attend our Shooting Sports meetings?

A – No, you can NOT require meetings for completion/exhibition of any 4-H project, with one exception: a safety meeting may be required of youth if the county instructor team wants to hold one safety meeting. An agenda with a focus on range safety procedures should be approved and on file in the county Extension office and with the 4-H Shooting Sports Coordinator prior to conducting the safety meeting. If a safety meeting is required, it should be offered in various formats (face-to-face, recording, paper) and/or at multiple times. Whether you hold a safety meeting or not, remember: *safety guidelines should always be reviewed each time 4-H members are on the range.*

Hunter Education

Q – Can youth take the Hunter Education classes in another county?

A – Yes. You can take the Hunter Education class wherever it works best for you. Youth 12 years old and older can take the class online (<https://www.hunter-ed.com/indiana/>). A Hunter Education certificate is valid throughout the U.S., Canada, and Mexico. See the IDNR website (www.inhea.com/) for more information.

Q – Can we require 4-H members to take the IDNR Hunters Education course before participating in our 4-H Shooting Sports program?

A – No.

Non-4-H members shooting

Q – Can parents, siblings, or friends of members shoot with the 4-H shooting sports members?

A – No. The liability insurance granted from Purdue to certified instructors applies ONLY to instructors working with 4-H youth. Do not jeopardize your program by allowing anyone but 4-H members to shoot. If public shoots are organized to involve non 4-H youth in grades 3-12, follow conditions outlined elsewhere in this handbook (p. 12)

Insurance coverage

Q – Does the 4-H liability insurance cover 4-H programs hosted at our Conservation Club?

A – Purdue University holds liability coverage for approved 4-H Shooting Sports activities held on approved ranges. A Certificate of Insurance (COI) may be obtained if the property owner requests one. The COI verifies the existence of the insurance and is valid for one calendar year. The 4-H Youth Development Extension Educator must make that request of the University on your behalf. A copy of the COI will be returned to the property owner and the 4-H Youth Extension Educator. This process typically takes 2-3 weeks to complete.

Q - What if a member is injured during a 4-H Shooting Sports Meeting?

A – First, be sure that the member receives any necessary medical treatment. All approved 4-H Volunteers and enrolled 4-H Members are provided with limited accident/injury insurance through a statewide policy purchased from American Income Life (AIL) Insurance Company by the Indiana 4-H Youth Development Program. Should there be an accident/injury during any approved 4-H event, the family will have the option to file a claim with AIL. In that case, the 4-H Youth Extension Educator would work with the family of the injured party and the 4-H Volunteer at the event where the accident/injury occurred to complete the necessary

paperwork. Complete an accident/incident report which the Educator will submit to Purdue University.

Q – What insurance coverage is available for 4-H Shooting Sports equipment?

A – Equipment and supplies owned by the 4-H Shooting Sports program are not covered by any insurance at the university level. Each county is responsible for insuring their own equipment against loss or damage. In many counties, the 4-H Shooting Sports group has worked with the County 4-H Council to obtain a rider policy on an existing Council policy to provide this insurance coverage.

Storing equipment

Q – Our Shooting Sports club just bought a new safe. I know that it has to be in a secure facility. Does it have to be in the Extension office?

A – The safe does not have to be located in the Extension office. Equipment can be stored in a secure location that is accessible to the Certified Shooting Sports Instructors who will be using it on a regular basis. If you decide to let one of your certified instructors have it at their home, be sure you (the coordinator) and 4-H Youth Extension Educator have a signed document that lists the address where the equipment is stored and the type and serial numbers of all firearms stored (see p. 23-26 for more details).

Adult help at meetings

Q – We have some parents that would like to help us, and we truly could use the adult help. Is there some way that these parents could go through a 4-H volunteer training so that they could help this year, and be qualified to go for instructor training in the fall? Some parents would just like to help us, to what extent can they? Can they help us look for lost arrows, in the grass when the line is cold? Can they put ammo in the ammo blocks? Put tape on targets?

A – Yes, parents can and are encouraged to help out, after they have completed the required Indiana 4-H Volunteer requirements. Generally, the more people involved, the better the program. It is also a great way for adults to learn more about the program and see if they are interested in becoming a certified instructor. The designation of Associate instructor is for approved 4-H adult volunteers who help on a regular basis. They can do all of the things you mention and more. They can even help on the range provided that they are under the direct supervision of a certified Shooting Sports instructor. They may also do any educational activities (other than shooting) with the youth. This is especially useful when there is a large group and long waits between the time the youth are on the range. An Associate instructor could show how to clean a gun or talk about sighting a gun or training hunting dogs or making an exhibit for the fair. They just can't shoot with a group of youth by themselves.

Specific requirements for 4-H volunteers

Q – What are the requirements to be a 4-H Volunteer?

A – The Indiana 4-H Youth Development program relies heavily on volunteers to operate the program and to extend the program to youth throughout the county. We take the safety and well-being of the youth in our program seriously. To help assure that we have the appropriate adults working with the youth in the program, we have very specific volunteer application and screening policies. Each individual who wishes to volunteer for the program will complete these according to the direction provided by the 4-H Extension Educator. The 4-H Extension Educator in each county is responsible to see that this process is completed and to place the approved volunteers into their approved volunteer roles.

As a part of the volunteer approval process, there is an annual re-enrollment requirement that each individual completes to remain as an active 4-H Volunteer in the program. This re-enrollment is typically completed via 4-H Online and provides the individual with the chance to re-commit to the Adult Behavioral Expectations. This is an annual process that begins on October 1 (the beginning of the new 4-H program year). In order to operate the 4-H Program effectively, we ask those wishing to volunteer for the next program year to do so as soon as possible after October 1. Re-enrollment must be completed before the individual offers a program involving your or makes decisions related to the 4-H Program. Follow-up efforts are made for those who have not completed the process. Those individuals who choose not to re-enroll in the program are not considered to be active 4-H Volunteers.

A Minors Safety and Child Abuse Reporting training requirement was added as a university-wide policy in 2015, for all Purdue University staff and volunteers (including 4-H Volunteers) to complete. This training is valid for one year, then must be repeated. Annual training requirements also include 4-H Orientation and Cultural Awareness.

Each 4-H Extension Educator must annually register the County 4-H Youth Development Program as a “Program Involving Minors” with the University. When the Educator registers the County 4-H Youth Development Program, he or she is certifying that all 4-H Volunteers are in compliance with this policy. Those 4-H Volunteers who have not completed the training and the re-enrollment process jeopardize their status as volunteers. Further, if we were to allow the volunteers to participate without having completed the required training, we would also jeopardize the 4-H Program. Thus, we do our best to ensure that our volunteers and program are in compliance!

For 4-H Volunteers who wish to be instructors in the 4-H Shooting Sports program, there is an additional required certification training that is offered through Purdue University’s partnership with the Indiana Department of Natural Resources. The Hunter Education Coordinators, Tim Beck and Chris Clark, along with the State 4-H Shooting Sports Instructor team, offer this training twice a year. Once certified in a discipline, the approved 4-H Volunteer is able to serve as a county instructor for range activities in that specific discipline.

Age to start Shooting Sports

Q – Are we required to let third graders participate in our program?

A – You are not required to start the Shooting Sports program at 3rd grade. However, if the younger 4-H members are ready and interested in shooting sports when they start 4-H, they won’t be able to complete 10 years in the project and they may lose interest if you exclude them. We recommend that you consider the Outdoor Skills discipline as an introductory class for your younger participants (3rd & 4th graders). This discipline offers a great way of introducing youth to the outdoors and Indiana wildlife. Another option is to start third graders in archery or air rifle and require youth to be older (perhaps middle school aged) for disciplines like shotgun and muzzleloading.

Shooters with disabilities

Q – This summer we had a 4-H member in our Shooting Sports program with special needs. I was worried about my ability to help this boy since I have no training in this area. Must I accept this youth into our classes?

A – You must include all youth to the fullest extent possible. It may be helpful to talk with the parents so you can determine what special needs the youth has, how they can best be accommodated, and if extra help is required. It can be both appropriate and reasonable in some cases to ask the parent or guardian to be present and involved with their child at shooting sessions to help with mobility challenges or to provide an extra set of eyes, if closer observation is required. While we want to include all youth, we must also continue to maintain the highest standards of safety. The book, *Teaching Shooting Sports to persons with disabilities* (ISBN 0-916682-66-8), may be helpful in making accessories to help Shooting Sports youth with mobility challenges. Additional resources are available with the “Inclusive 4-H” link on the State 4-H Website: <https://extension.purdue.edu/4-H/volunteer/resources-and-development/inclusive-4-h.html>.

Youth owned equipment

Q – Can 4-H members use their own equipment?

A – Yes, It is okay for youth to use their own equipment in all the disciplines, but we ask that the instructors inspect the firearm or archery equipment at each meeting. Some counties may have enough equipment and prefer that 4-H members do not bring their own. Other counties do not have equipment, so they have no choice but to ask the 4-H members to bring firearms or bows that they have. Also, if a young person stays with the program and advances, they probably should be using their own, possibly higher quality equipment, which they learn to handle and take care of properly.

Note: We highly recommend that all firearms (club and individually owned) are checked by a gunsmith each year.

Reloading

Q – I am certified by the NRA as a Reloading Instructor. Can I teach a class on reloading for 4-H shooting sports members?

A – You can demonstrate the process of reloading but may not shoot the reloads, nor allow the 4-H members to reload.

Threatening behavior

Q – An instructor overheard a 4-H member stating that he wanted to learn how to shoot so he could “take care of someone at school.” How do we handle this situation?

A – Youth that threaten the safety of others (verbally or with equipment) need to be dealt with immediately. Contact the parents to make them aware of the problem. Contact your County 4-H Youth Extension Educator for guidance on how to proceed. The Educator will discuss the situation with the state Extension Specialist to decide how best to address this behavior.

Hunting

Q – Can we take the 4-H Shooting Sports members hunting? We will have one adult for every two youth.

A – No. Purdue’s liability insurance policy does not allow Shooting Sports volunteers to take youth hunting as a 4-H activity. There are too many variables in this situation that are beyond the control of the certified instructor.

Competition

Q – My rifle instructor said he was told 4-H discourages competition. I did not know that. It is not our priority, but some kids ask for some competition and it can be fun. There are tons of competition in the other projects. Did I miss something? Are shooting competitions OK?

A – When the Indiana 4-H Shooting Sports program began (1983), the state Shooting Sports team decided against holding competitions. The stated goal of this program is to teach safe and ethical use of firearms and to assure that every participant has a good experience. A focus on competition often detracts from these goals, particularly for younger members. However, counties can have competitions, which may give older youth a goal to achieve. You might hold a competition with another county for the older youth or among your older club members. Younger members can compete against their previous scores to see how they are improving. Make sure that all participants have a positive experience. Randolph County holds a regional competition that is well run. There are also many non-4-H competitive events that you can inform the older youth about if you feel they would be interested in attending with their parents. (This would be similar to youth attending an Open Horse show.)

Muzzleloading age recommendation

Q – What age should the child be in order to begin the muzzleloading program? Are there state rules in regard to the subject and age requirement? In our county the rifle and shotgun projects require the youth to be in 7th grade. Any recommendations will be helpful.

A – There are no state guidelines for what age/grade a 4-H member should be for any of the shooting sports disciplines. We generally recommend, however, that shotgun and muzzleloading are offered to the older youth because they are more expensive (ammunition and equipment), the firearms are heavier so they are more appropriate for older youth, and it gives 4-H members a reason to come back another year.

Certified instructors don't help

Q – What can we do about a newly certified instructor that the county paid to attend the certification workshop and then is never available to help with the program?

A – Start by having a conversation with the instructor to see how he or she would like to help. Share your concerns about his/her lack of participation and stress the importance of having certified volunteers available to work with the 4-H members. Some counties have begun to require that volunteers pay for the certification workshop and then reimburse them the costs after the volunteer has helped with the county program for a period of time. Some counties will reimburse half the cost after one year of service and the other half after another year of service. This helps to make sure the people who show an interest will actually attend the workshop and will continue to work with the program.

Shotgun swing-stops

Q – Our instructors that went to the training talked about some kind of stop that they had in the shotgun discipline. They are interested in building that here for our range for the kids to use. Can you send me what that is or how it was made? Our Fair Board is willing to help with the cost if they knew what it was made of.

A – They may be talking about swing-stops we use at each station. They may be made from metal, like the ones that we use, or from other material like PVC Pipe. Search online for exact specifications for sporting clays swing-stops or stations. Or, they could use 5 gallon buckets filled with sand and simply stick the PVC Pipe in those buckets to make swing stops. The Double Traps will do the same thing and they are under \$350.00 dollars and adjustable.

General Requirements and Suggestions

Grade of members –

State policy will permit students in grades 3-12 to participate in 4-H Shooting Sports. Students in grades K-2 (or younger) are NOT permitted to participate on firearm or archery ranges. Otherwise, it is up to each Shooting Sports instructor team working with their county 4-H Youth Extension Educator to decide the appropriate age to begin this program in your county. The decision should be based on the ratio of instructors to youth, the maturity level of the youth, the disciplines offered, your instructors' level of comfort when working with the younger youth, and the size of equipment you have. The Outdoor Skills discipline has many group activities and is often the best choice for younger 4-H members.

4-H Shooting Sports Instructor Certification Workshop –

Recruit new volunteer instructors. They will need to attend the certification workshop if they are going to take responsibility for leading a 4-H Shooting Sports discipline. Parents may help a certified instructor without attending the workshop, but they must first be approved 4-H Volunteers and under the direct observation of the instructor when any shooting is occurring.



4-H Enrollment and Standardized Statements

There is an annual formal enrollment process for each young person who chooses to participate in the 4-H program. This process is completed through the County Extension Office and is available via 4-H Online and in paper versions. Standardized liability, behavior, and photo policy statements are included. Both a parent/legal guardian and each 4-H member must sign the statements. (4-H members 18 and over are considered legal adults and sign parent/guardian statements.)

The member behavior statement reads: “I agree to follow the rules, policies and expectations of the 4-H program and will conduct myself in a courteous and respectful manner by exhibiting good sportsmanship and good behavior. I understand that failing to do so will result in sanctions, discipline, and/or dismissal from the program.”

Adults who are not 4-H Volunteers and youth who are not 4-H members may not shoot at 4-H meetings since they are not covered by Purdue's liability.

Financial Reporting

It is critical that the 4-H Shooting Sports Coordinator submits yearly financial reports as requested by the 4-H Extension Educator. This is important for the county 4-H Shooting Sports program for two reasons:

- So there are no questions of how the funds are being handled from the Shooting Sports team, your County Extension Office, parents, or the public.
- For the required 5-year financial review/audit (and when there is a change of staff)

Note: Filing of an e-Postcard with the IRS for each EIN is required by May 15 annually.

Managing 4-H Club Funds

General Guidelines:

- Checking/savings accounts
 - Opened with a unique Employer Identification Number (EIN) obtained from the IRS. (No personal Social Security numbers on the account.)
 - Use a duplicate check system.
 - Account has two signatures (of unrelated persons).
- Maintain a list of receipts and expenses.
- Keep original receipts for purchases.
- Present a treasurer's report at each club meeting.
- Provide official receipts for donations (dollars, equipment, other resources).
- When conducting fundraising events in support of 4-H Shooting Sports, remember that Purdue Extension and State 4-H Program policies *prohibit* any games of chance (including raffles, bingo, etc.)
- Complete and submit Annual 4-H Club/Unit Financial Report to the Extension Office.
- File the appropriate IRS Form 990 Series return (e-Postcard) annually by May 15th.

Annual 4-H Club Financial Report

In order to remain in compliance with federal guidelines for the 4-H Program, the following policy regarding 4-H Unit/Club finances has been adopted by the State 4-H Program:

1. EVERY 4-H Unit (council, club, committee, project group, etc.) shall maintain a record of its activities, a record of the contributions it has received, prepare and keep on file a record of its financial transactions, file all necessary state and federal forms, and submit an annual report to the Extension Educator responsible for the County 4-H Program. This information will be due to the 4-H Council each year.
2. All 4-H Units/Clubs will have their financial records reviewed/audited by a committee designated by the 4-H Council at least once every 5 years. The reviews/audits will be requested of units/clubs on a random, rotating basis.

It is critical that the 4-H Shooting Sports Coordinator submits a yearly financial report as requested by the 4-H Educator. This enables the county Shooting Sports program to be transparent in its use of public funds and helps answer questions of how funds are being handled from the Shooting Sports team, your County Extension Office, parents, or the public.

Tax Exempt Status for 4-H Clubs and Organizations

Authorized 4-H groups are exempt from paying federal income tax on funds raised on behalf of 4-H. Purdue University holds the Group Exemption Number with the IRS to provide federal tax exemption status to 4-H Clubs and Affiliates in Indiana. The 4-H Shooting Sports Coordinator must work with the County 4-H Youth Extension Educator to assure filing is done properly.

- Tax exempt organizations must file Form 990 annually. Organizations that have gross receipts of \$50,000 or less file a Form 990-N (e-Postcard).
- Donors may deduct contributions to 4-H clubs and affiliated 4-H organizations.
- This status addresses *only* federal income tax – it *does not* exempt entities from paying state, local, hotel, property, sales or other taxes.
- Groups must be under guidance and control of Purdue Extension to qualify for this tax exempt status.

A note about gifts and grants:

Gifts/donations [\$, guns (“item”), targets, ammunition]

- The Extension Office should send a thank you to the entity who made the donation, preferably with 4-H member notes.
- Gifts to clubs do not need to come to campus.

Grants

- If anyone writes a grant that commits Extension staff time to do planning and/or delivery, it **MUST** come through campus.
- Grants for gifts/equipment that are submitted by 4-H Volunteers do not need to come through campus.

Discipline Bars

Purchasing the Indiana 4-H Shooting Sports discipline bars is a way to designate instructors or to use for youth who complete a discipline. Some counties use these on caps or special shirts or vests for instructors. This can be especially helpful to the women instructors who may not receive the same respect as the male instructors.

You may purchase discipline bars for your instructors and youth. Some counties like to provide them to youth at completion events. Order through your local Extension Office (they will order from Purdue’s Education Store, www.edustore.purdue.edu).

Cost: package of 10 discipline bars for \$16-20 (August, 2021).

Order numbers are:

- | | | |
|--------------------|---------------------------|--------------------------|
| • 4-H-855, Archery | • 4-H-856, Outdoor Skills | • 4-H-857, Muzzleloading |
| • 4-H-858, Pistol | • 4-H-859, Rifle | • 4-H-860, Shotgun |

Instructor rockers are only available to certified instructors. Therefore, they are distributed at the certification workshops and are not available for purchase.

The 4-H program will maintain supplies of the discipline bars listed above at The Education Store for your use with instructors and youth. We do not have county rockers. You may order county rockers (100 minimum) from Apple Group or Excel Group (see contact information below):

Apple Group
112 N. East Street
Tipton, IN 46072-1740
PH: 1-800-695-5121
<http://www.applegroup.com/>

Excel Group
156 Sagamore Pkwy West
West Lafayette, IN 47906
Ph: (765) 447-4593
<http://excelgrp.com/>

The color is gold with kelly green text.

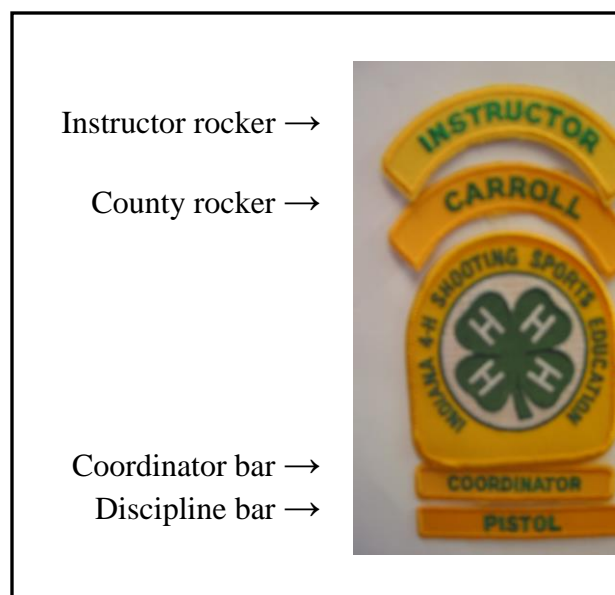

Instructor rocker →

County rocker →

Coordinator bar →

Discipline bar →

Project Completion - Project Exhibition

The guidelines for exhibition and completion of 4-H projects are given below. This text was taken from the Indiana 4-H Procedures and Policies Handbook.

Exhibition:

Exhibition of 4-H projects in local, county, or state exhibits/fairs, virtually or in person, is voluntary on the part of the exhibitor. The exhibition of 4-H projects provides 4-H members an opportunity to display their 4-H projects, enter into competition and participate in an educational/social environment with peers. With exhibition also comes the responsibility for abiding by all the terms and conditions pertaining to the respective 4-H project.

Completion:

The completion of a 4-H experience may include a variety of options and must not be misinterpreted as exhibition of a project at a local, county or state fair. There are a number of ways that a young person may participate in the 4-H Youth Development Program in addition to the club-based option. Participating in these 4-H opportunities enable the youth to build skills that will serve them well throughout their adult lives. 4-H members are considered complete in their educational experience for that year when they have:

1. Completed the “official” 4-H member enrollment process prior to the established and published date for enrolling.
2. Had an officially recognized 4-H volunteer/extension educator verify the existence of the completed project or member’s participation in a 4-H educational experience.
Additionally, 4-H members who participate in a club- or fair-based 4-H project will submit a completed 4-H record sheet based on printed or web-based educational materials used by Indiana 4-H prior to the established and published date.

Though exhibiting in local, county, and state exhibits/fairs is not required for project completion, as it does not necessarily relate directly to content and skills learned in the development of the 4-H project, project exhibition is encouraged as a continuation of the educational experience. Exhibits may be submitted virtually or in person.

Note:

In a statement from our federal partner in Washington, DC, the following statement appears: *“Anytime there are procedures for exclusion of individuals from events which use the 4-H name there are potential challenges to enforcement of the exclusions. The challenges have a substantial potential to prevail and they frequently result in negative publicity for the organization. Therefore, before choosing a policy of exclusion it is wise to evaluate the exclusion being considered, to be sure there is an overwhelming educationally based need for the exclusion.”*

In Short:

Extension employees and volunteers are obligated to eliminate (and should not create) any practices that limit, deprive, or tend to deprive any youth of opportunities for membership and/or participation in the Indiana 4-H program.

**Office Use Only:**Range Plan Approval: _____
(signature)_____
(date)

RISK MANAGEMENT OFFICE

_____ County 4-H Shooting Sports Range

Our Shooting Sports range is located at: _____

The State 4-H Office must have a range layout for property used for 4-H Shooting Sports firearm and archery shooting. These layouts must be updated with the State 4-H Office any time there is a change to a range.

Sketch the shooting range, indicating which disciplines meet in which areas, and the general size of each area. If your Shooting Sports club shoots at more than one location, copy this form and attach the location and range sketch for each.

Complete and forward to: 4-H Shooting Sports Coordinator
615 W. State Street
West Lafayette, IN 47907-2053



Request for Certificate of Insurance

Form RM02
Revised 03-18

Send completed form to Risk Management at RiskMgmt@purdue.edu.

Request Date: _____

Your Information:

Name: _____

Email: _____ Phone: _____

Certificate Holder Information (the entity requesting the certificate from the University):

Organization Name: _____

Street Address: _____

City, State, Zip: _____

Email Address: _____ Fax: _____

Certificate Purpose: *If certificate is for a specific event, please provide event name, date, and who will participate.*

Additional Insured/Other Special Wording: _____

Must be completed and submitted by 4-H Extension Educator at least 3 business days prior to event.

FOR RISK MANAGEMENT USE ONLY:

Named Insured: Purdue University _____ Purdue Affiliates _____

Master Policy:

University - GL/AL \$5M _____ GL/AL/EL \$5ML _____ LPL \$1M _____ Property _____ Aviation _____

Affiliates - GL \$1M/\$2M _____ Property _____

Additional Insured Requested: Yes _____ No _____

Loss Payee Requested: Yes _____ No _____

Delivery Method: Mail _____ E-Mail _____

RESET FORM

Available at:

https://www.purdue.edu/business/risk_mgmt/pdf/Form%20RM02%20Updated%203-18.pdf#RM02

Running Meetings

Inclusion – 4-H programs and activities are open to all youth.

Extension employees and volunteers are obligated to eliminate (and should not create) any practices that limit, deprive, or tend to deprive any youth of opportunities for membership and/or participation in the Indiana 4-H program.

Federal guidelines prohibit *required* meetings, with rare exceptions. One such exception is that one safety meeting can be required of youth in 4-H Shooting Sports. Please offer multiple dates and/or delivery options whenever possible. See “Safety Meeting” in this section for suggested topics.

Evaluating Shooters

The following evaluations are used with permission from Virginia 4-H, Virginia Cooperative Extension Virginia Tech and Virginia State Universities.

Archery - Ideas for Review & Evaluation

- Demonstrate your knowledge of archery safety, including:
 - Zone of fire and direction
 - Targets and target identification
 - Equipment
 - Arrow retrieval
 - Range operation
- Demonstrate your knowledge of archery equipment, including:
 - Bow types and materials
 - Parts of bows and arrows
 - Arrow shaft materials
 - Arrow points and fletching
 - Quivers
 - Finger tabs, gloves, arm guards
- Demonstrate proper archery shooting form, including:
 - Eye dominance
 - Stance and posture
 - Bow-hand grip
 - Nocking the arrow
 - Setting the hook
 - Raising the unit
 - Draw
 - Anchor
 - Aim
 - Release
 - Follow through
- Shoot a 3-shot group at 10 yards (7" or less)
- Demonstrate your ability to move the group to the aiming point
- Shoot 5 arrows at each of the following distances and record your score (Standard at the discretion of the instructor. If available, use a standard 40 cm (16") target, 9 point bull.)

Used with permission from:
 Virginia 4-H
 Virginia Cooperative Extension Virginia Tech and Virginia State
 Universities

Distance	Score
10 yards	
15 yards	
20 yards	
25 yards	

Hunting - Ideas for Review & Evaluation

- Demonstrate your knowledge of hunting safety, including:
 - Basic firearm safety
 - Muzzle control in the field
 - Target identification
 - Equipment safety and handling
 - Zone of fire
 - Blaze orange
 - Planning a safe hunt
- Discuss the history of hunting and why people hunt today
- Discuss some of the concerns you have heard about hunting and your response.
- Demonstrate your knowledge of the basic wildlife management principles, including:
 - Necessary habitat components
 - Carrying capacity
 - Predator and prey relationships
 - The role of hunting regulations in management of wildlife populations
- Discuss the following items for several species of game in your area, using the current Indiana Hunting Regulations (www.in.gov/dnr/fishwild/2343.htm):
 - Open seasons
 - Bag limits
 - Licenses required
 - Lawful methods of taking
 - Unlawful methods of taking
- Demonstrate your knowledge of one, or more, of the following hunting arms and ammunition:
 - Archery
 - Handguns
 - Rifles (small bore, highpower, and blackpowder)
 - Shotguns
- Demonstrate your knowledge of proper field care of game

Used with permission from:

Virginia 4-H

Virginia Cooperative Extension Virginia Tech and Virginia State Universities

Muzzleloading - Ideas for Review & Evaluation

- Demonstrate your knowledge of muzzleloader safety, including:
 - The three basic rules of gun safety
 - Range rules
 - Equipment
 - Loading and firing procedures
 - Use of appropriate ammunition
 - Range operations
 - Eye and ear protection
 - Zone of fire and direction
 - Targets and target identification
- Demonstrate your knowledge of muzzleloader equipment, including:
 - Muzzleloader types
 - Parts of the muzzleloader
 - Propellant materials
 - Projectiles
 - Muzzleloader accessories
- Demonstrate the proper steps in loading and firing a muzzleloader
- Shoot a 3-shot group (standard set by instructor)
- Shoot a 3-shot group by moving the group to the aiming point (reworded from VA)
- Load and Shoot 10 and record your score
(Standard at the discretion of the instructor.)

Used with permission from:
 Virginia 4-H
 Virginia Cooperative Extension
 Virginia Tech and Virginia State
 Universities

Shot	Distance	Score
1		_____ of a perfect _____
2		_____ of a perfect _____
3		_____ of a perfect _____
4		_____ of a perfect _____
5		_____ of a perfect _____
6		_____ of a perfect _____
7		_____ of a perfect _____
8		_____ of a perfect _____
9		_____ of a perfect _____
10		_____ of a perfect _____

Pistol - Ideas for Review & Evaluation

- Demonstrate your knowledge of pistol safety, including:
 - The three basic rules of gun safety
 - Range rules
 - Equipment
 - Use of appropriate ammunition
 - Range operations
 - Eye and ear protection
- Demonstrate your knowledge of pistol equipment, including:
 - Pistol types
 - Parts of the pistol
 - Ammunition (types, components, function)
 - Pistol operation
- Demonstrate proper pistol shooting form, including:
 - Eye dominance
 - Stance (one handed and two handed)
 - Shooting positions
 - Sight alignment/sight picture
 - Trigger control
 - Follow through
- Shoot a tight group in the bench position of one, or more, of the following:
(Standard set by instructor)

Supported position	Two-handed position
Air pistol at 10 meters	Air pistol at 10 meters
22 pistol at 50 or 75 feet	22 pistol at 50 or 75 feet

- Shoot 10 shots with one or more of the following rifles and record your score
(Standard at the discretion of the instructor. Air Pistol (B-40 target at 10 meters) or pistol (B-2 or B-3 at 50 feet or B-6 at 75 feet)

Shot	Distance	Score
1		_____ of a perfect _____
2		_____ of a perfect _____
3		_____ of a perfect _____
4		_____ of a perfect _____
5		_____ of a perfect _____
6		_____ of a perfect _____
7		_____ of a perfect _____
8		_____ of a perfect _____
9		_____ of a perfect _____
10		_____ of a perfect _____

Used with permission from:
Virginia 4-H
Virginia Cooperative Extension Virginia
Tech and Virginia State Universities

Rifle - Ideas or Review & Evaluation

- Demonstrate your knowledge of rifle safety, including:
 - The three basic rules of gun safety
 - Range rules
 - Equipment
 - Use of appropriate ammunition
 - Range operations
 - Eye and ear protection
- Demonstrate your knowledge of rifle equipment, including:
 - Rifle types
 - Parts of the rifle
 - Ammunition (types, components, function)
 - Rifle operation
- Demonstrate proper rifle shooting form, including:
 - Eye dominance
 - Bench position
 - Shooting positions
 - Use of the sling
 - Sight alignment/sight picture
 - Trigger control
 - Follow through
- Shoot a tight group in the bench position of one, or more, of the following:
 - Air rifle - 10 meters
 - 22 rifle - 50 meters
- Shoot 10 shots with one or more of the following rifles and record your score (Standard at the discretion of the instructor. Air Rifle (AR-5 at 10 meters); 22 rifle (A-17 or A-36 at 50 feet or A-23 at 50 yards)

Used with permission from:

Virginia 4-H

Virginia Cooperative Extension Virginia Tech and
Virginia State Universities

Shot	Distance	Score
1		_____ of a perfect _____
2		_____ of a perfect _____
3		_____ of a perfect _____
4		_____ of a perfect _____
5		_____ of a perfect _____
6		_____ of a perfect _____
7		_____ of a perfect _____
8		_____ of a perfect _____
9		_____ of a perfect _____
10		_____ of a perfect _____

Shotgun - Ideas for Review & Evaluation

- Demonstrate your knowledge of shotgun safety, including:
 - The three basic rules of gun safety
 - Range rules
 - Equipment
 - Use of appropriate ammunition
 - Range operations
 - Eye and ear protection
- Demonstrate your knowledge of shotgun equipment, including:
 - Shotgun types
 - Parts of the shotgun
 - Bore sizes
 - Choke
 - Action types
 - Ammunition (5 basic parts of a shell and how a shell works)
 - Shotgun operation
- Demonstrate proper shotgun shooting form, including:
 - Eye dominance
 - Stance
 - Gun ready position
 - Mounting the shotgun
 - Swing to the target
 - Trigger pull
 - Follow through
- Shoot a series of moving clay targets (difficulty level at the discretion of the coach and determined by the age and experience of the shooter)
- Demonstrate your ability to properly care for your shotgun, including:
 - Cleaning
 - Storage
 - Transporting

Used with permission from:

Virginia 4-H

Virginia Cooperative Extension Virginia Tech and Virginia State Universities

Meeting Suggestions

- Have water available
- Have restrooms available
- Ensure facilities are accessible to all participants
- Provide adequate hand sanitizer and some extra face coverings
- Complete and submit health safety plan for approval
- Communications – cell phone, LMR (land mobile radio), hand radio etc.
- Information about the meeting (time, date, place) – listed with your County Extension Office, EMS, Law Enforcement (your county office may pass your meeting dates on for you)
- First aid kit and, preferably, someone trained in first aid
- Comfort kit with items such as sunscreen and insect repellent
- Incident reports – procedures and forms
- Be sure the county office has an approved range plan for the range you are using

A form for member information can help your discipline instructors keep track of the 4-H members and give information about how to contact them if a meeting must be canceled. Remind your instructors that this is confidential information and may not be shared.

<p>NOTE: This form is intended for use by the discipline instructor.</p>

Member Information

Name: _____

Address: _____

City/Town: _____

Zip code: _____

Home Phone: _____

Cell Phone: _____

OK to text?: _____

Grade in
School: _____

Date of Birth: _____

Emergency
Contact: _____

Years in 4-H? _____ Years in Shooting Sports? _____

Other 4-H Projects? _____

Any health-related conditions we should be aware of? (e.g., food or other allergies; medication)

Club Meeting Schedule

Month	Date	Time	Place

Club Guidelines

- 1. _____
- 2. _____
- 3. _____
- 4. _____
- 5. _____

Safety Meeting

Federal guidelines do not allow 4-H clubs to require that youth attend meetings. The rare exception is that a safety meeting for Shooting Sports may be required of participants. The county instructor team should decide if a meeting will be required, who will be required to attend (first time members, members in years 1-3, all Shooting Sports members), who will teach which items, and if a test will be given. You may use the following agenda or adapt it to fit your program and the disciplines that the county offers or create your own agenda. The agenda for the safety meeting must be approved by and on file with the County 4-H Youth Development Extension Educator and the 4-H Shooting Sports Coordinator prior to the meeting. If a safety meeting is required, the meeting should be offered at multiple times (covering the same information) and offered in multiple formats (e.g., face-to-face, recorded video, online resources, printed materials).

Suggested Agenda

- Introductions
- Cardinal Rules of Safe Shooting (3)*
- Eye and Ear Protection*
- Explanation of Range Rules and Range Commands
 - Range Safety Officer's word is law
 - Eye protection is required
 - Ear protection is required with firearms
 - Cease Fire – anyone can call, used for unsafe behavior
- Lead (handling and safety)*
- Behavior Expectations
 - Pay attention to instructors – active listening
 - Zero tolerance of disruptive behavior. Everyone must be able to hear and see the instructors
 - If someone does something that is deemed dangerous, they may have to sit out of shooting for that night. If you repeatedly create a dangerous situation, you will not be able to continue in the program.
- Posture correction (non-threatening, hands-on instruction)
- Other safety information that youth should have (where parents should park, site specific rules and regulations, etc.)
- Dress for: weather, some disciplines will shoot prone, no loose clothing in archery
- Parents – please let the instructors know of anything they might need to know regarding their children (for example: insect bite allergies, ear tubes)

*Note: These topics are discussed in the 4-H Shooting Sports youth manual (4-H 950).
Instructors might want to assign pages 2&3 for review.

Rationale and Additional Information

Cardinal rules of safe shooting – these rules are the standard for safety when handling firearms and archery equipment. They are:

- Always keep the arrow or muzzle pointed in a safe direction
- Always keep your finger off the trigger until ready to shoot
- Always keep your firearm or bow unloaded until ready to use

Eye and ear protection – eye and ear protection are essential for the safety of all shooters. Eye and ear protection are mandatory for all shooters, coaches, and others on the range. The likelihood of an injury is relatively small, but the impact of such an injury could be serious. Stray or deflected pellets, target chips, gases and powder residue from shotguns and other foreign objects have the potential to damage the eyes. Wearing shooting glasses protects them. Many shooters combine their eye protection with corrective lenses or tinted lenses that increase contrast, reduce light intensity, or enhance vision in other ways.

The sound levels produced by any powder firearm can cause hearing damage. Hearing damage is usually gradual, so the shooter seldom notices the loss until it is serious. The damage is cumulative and permanent. The damage from the prolonged exposure during target shooting is a real and present threat. Inexpensive and comfortable hearing protection (plugs or muffs) are available. Some shooters use both plugs and muffs for added protection. Choose the type of protection that fits your shooting style and budget. Always wear them on the range.

Range rules and commands – give the guidelines and procedures that will be followed by everyone on the range. Range Commands will vary from discipline to discipline and range to range. Range commands give the guidelines and procedures that will be followed by everyone on the range. It is especially important that youth understand the *Cease Fire* command and that anyone can call a *Cease Fire*. The *Cease Fire* is used to stop unsafe behavior immediately. It is important that youth always read, understand, and follow the range commands that pertain to the range they are using.

Lead – information about the toxicity of materials youth may be handling. Avoid eating or drinking on the range. Never eat or drink until after your hands have been washed. Lead from the balls or exposed lead ammunition is of concern. Hands should always be washed after handling the 100% pure lead balls used in muzzleloaders. Lead ball should never be placed in the mouth. Percussion caps and centerfire primers are also a source of lead. The priming compound used in modern caps is lead styphnate. For this reason, care should be taken when handling caps. Lead exposure is cumulative. (Suggestion for coaches and shooters: always have anti-bacterial moist towelettes available on the range so you can wipe your hands carefully once you are through shooting.)

Behavioral expectations – clear guidelines of what is appropriate behavior on the range, what will be expected, and the consequences of inappropriate behavior. Disruptive behavior will not be tolerated. Everyone must be able to hear and see the instructors at all times. Youth must use active listening skills throughout the Shooting Sports meetings. If anyone does something that is deemed dangerous, they may have to sit out of shooting for that night. If they repeatedly create a dangerous situation, they will not be able to continue in the program. Consult with the 4-H Extension Educator for additional guidance.

Other safety information – safety guidelines and recommendations based on the particular ranges used. This information includes safety guidelines and recommendations based on the particular ranges used. Examples: where parents should park, stand when watching shooting, when to talk to their child, etc.

Dress – discussion of types of clothing that can pose safety concerns. Discuss the types of clothing that can pose safety concerns (e.g. no loose clothing in archery). This discussion may also include information about appropriate clothing for different weather and shooting situations (e.g., some disciplines will shoot prone).

Name: _____

4-H Shooting Sports Safety Quiz

1. Complete the 3 Cardinal Rules of Safe Shooting:
Always keep the arrow or muzzle pointed _____.
Always keep your finger _____ until ready to shoot.
Always keep your firearm or bow _____ until ready to use.
2. Wearing shooting glasses protects your eyes from _____.
3. Ear plugs and muffs protect your ears from _____.
4. Are Range Rules the same for all ranges? (circle one) YES NO
5. What do you do when someone calls "Cease Fire?"
6. Is lead a concern in the 4-H Shooting Sports discipline that you signed up for? (circle)
Yes NO
7. What must you do after handling lead?
8. Why is active listening especially important for 4-H members taking Shooting Sports?

4-H Shooting Sports Safety Quiz

Note: youth do not need to answer exactly as given below but they should have the general idea.

1. List the 3 Cardinal Rules of Safe Shooting:

Always keep the arrow or muzzle pointed in a safe direction.

Always keep your finger off the trigger until ready to shoot.

Always keep your firearm or bow unloaded until ready to use.

2. Wearing shooting glasses protects your eyes from – There are many correct answers, including: stray or deflected pellets, target chips, gases and powder residue from shotguns and other foreign objects.

3. Ear plugs and muffs protect your ears from loud noises from firearms.

4. Are Range Rules the same for all ranges? (circle one) YES

- the correct answer is NO



5. What do you do when someone calls “Cease Fire?”

Stop whatever you are doing and wait for instructions from the Range Officer.

6. Is lead a concern in the 4-H Shooting Sports discipline that you signed up for? (circle)

Yes

NO

The correct answer will depend on the discipline. Lead is not a concern for archery, but is a concern (to varying degrees) for the other disciplines.

7. What must you do after handling lead?

Wash your hands.

8. Why is active listening especially important for 4-H members taking Shooting Sports?

So that you, other youth, and the adults can stay safe. (They might also say – to hear all the rules, to pay attention, because shooting equipment can be dangerous, etc.)

The Round Robin

Many county instructor teams like to have a round robin to introduce 4-H members to the variety of instructors and disciplines that are offered in their county. You can have the members change disciplines at each meeting or have them attend the same discipline for two meetings.

An example from a county with a large enrollment and offering all 6 Shooting Sports disciplines is given below. The youth are divided into six groups and attend each discipline for two weeks. This works especially well when all the groups are able to meet at one place. In the example the club meets at the county fairgrounds and holds a general 4-H Shooting Sports meeting before breaking into disciplines.

Date	Group 1	Group 2	Group 3
Feb 4	Archery	Outdoor skills	Muzzleloading
Feb 11	Archery	Outdoor skills	Muzzleloading
Feb 25	Outdoor skills	Muzzleloading	Pistol
March 4	Outdoor skills	Muzzleloading	Pistol
March 25	Muzzleloading	Pistol	Rifle
April 1	Muzzleloading	Pistol	Rifle
April 8	Pistol	Rifle	Shotgun
April 15	Pistol	Rifle	Shotgun
April 29	Rifle	Shotgun	Archery
May 6	Rifle	Shotgun	Archery
May 13	Shotgun	Archery	Outdoor skills
May 20	Shotgun	Archery	Outdoor skills
Date	Group 4	Group 5	Group 6
Feb 4	Pistol	Rifle	Shotgun
Feb 11	Pistol	Rifle	Shotgun
Feb 25	Rifle	Shotgun	Archery
March 4	Rifle	Shotgun	Archery
March 25	Shotgun	Archery	Outdoor skills
April 1	Shotgun	Archery	Outdoor skills
April 8	Archery	Outdoor skills	Muzzleloading
April 15	Archery	Outdoor skills	Muzzleloading
April 29	Outdoor skills	Muzzleloading	Pistol
May 6	Outdoor skills	Muzzleloading	Pistol
May 13	Muzzleloading	Pistol	Rifle
May 20	Muzzleloading	Pistol	Rifle

Notes:

- The disciplines that your county offers will depend, of course, on your certified instructors.
- If your instructors are not able to meet at the same time or place it will make it much more difficult for parents to get the 4-H members to the various meetings (and remember where they are supposed to be!)

Dubois County example: meetings every Thursday

6:30 – 7 pm, general meeting, guest speakers, activities, etc.

7-9 pm, round robin of disciplines

Instructor Resources

4-H Opportunities

Scholarships

Each year the 4-H Foundation gives over \$100,000 in college scholarships to eligible 4-H members. Ask your 4-H Youth Development Extension Educator for more information and visit: <https://extension.purdue.edu/4-H/get-involved/scholarships.html>.

Trips

4-H Academy @ Purdue is held in June on a variety of topics on the Purdue University campus for High School aged youth. Topics include animal species, aerospace, food, citizenship, journalism, personal finance, science & technology, plant, natural resources, and more.

State 4-H Jr. Leader Conference is a leadership development opportunity held for high school students in mid-June.

4-H Round-Up is a 3-day Career Exploration experience on the Purdue University campus in late June for youth who have completed grades 7-9.

4-H Citizenship Washington Focus is for youth aged 15 and over who stay at the National 4-H Center in late June/early July with others from across the nation to learn about citizenship, meet their senators and representatives, attend workshops and sight see around Washington D.C.

Teens as Teachers is 3-day conference in late February that provides youth with instruction on how to teach their peers about certain topics of interest.

Indiana 4-H Leadership Summit is a one-day leadership development opportunity for youth and adult volunteers, and recognizes volunteers and scholarship recipients.

To learn about additional state and national 4-H opportunities, visit: <https://extension.purdue.edu/4-H/get-involved/state-programs/index.html>.

Career Development Events (CDE's)

Career Development Events occur throughout the state during different times of the year. They are competitive events that allow youth to showcase their knowledge on a specific topic. Most CDE's offer individual and team entries. The Wildlife Habitat Education Program (WHEP) CDE may be of particular interest to 4-H Shooting Sports Members.

More information is available at: <https://extension.purdue.edu/4-H/get-involved/state-programs/career-development-events/index.html>.

Contact your County 4-H Youth Development Extension Educator for additional information about each of these and other opportunities that are available to 4-H members. Each county sets its own registration deadlines. Many offer full or partial scholarships to cover the members' registration fees.

Bullying

Bullying Prevention and Response

Website: www.stopbullying.gov/

From the website:

For children and youth to thrive in their schools and communities, they need to feel safe and be safe — socially, emotionally, and physically. They need to feel as if they belong, and they need to feel valued. Youth, parents, schools, communities, and others have a role to play in building positive, supportive environments for children and youth, promoting acceptance and respect among all individuals, and ultimately, fostering youth development and learning. Bullying is a form of youth violence, aggressive behavior that is intentional and that involves an imbalance of power or strength. Although definitions of bullying vary, most agree that bullying usually includes:

- attack or intimidation with the intention to cause fear, distress, or harm that is either:
 - physical (e.g., hitting, punching),
 - verbal (e.g., name-calling, teasing), or
 - psychological/relational (e.g., rumors, social exclusion);
- a real or perceived imbalance of power between the bully and victim; and
- repeated attacks or intimidation between the same children over time
(Farrington & Ttofi, 2010).

Bullying can occur in person or through technology, called "electronic aggression" or "cyberbullying."

Understanding bullying is complicated by the fact that a young person can be a bully, a victim, or both a bully and a victim (called "bully-victims"). (Wang, Iannotti, & Nansel, 2009).

The Federal Partners in Bullying Prevention Steering Committee have partnered with the Interagency Working Group on Youth Programs to share information the federal government has prepared to help prevent and address bullying in communities.

Characteristics of Youth: Ages & Stages

Effective youth instructors understand that youth have very different abilities and interests. The publication, *Ages and Stages of Child and Youth Development, A Guide for 4-H Volunteers* (NCR 292) discusses Youth Development Stages and is an excellent guide. A few notes are given below.

Youth Development Stages

Understanding the physical, mental, social, and emotional development of youth will help you when working with the 4-H members in your club. No two youth develop at the same rate and transitions are often gradual. Your teaching and involvement helps 4-H club members grow and mature and makes 4-H a rewarding and fulfilling experience.

Activities at 4-H club meetings do not always work as you had planned. Sometimes youth talk among themselves rather than listening to you; sometimes no one comes to a planned field trip; and sometimes no one speaks up when you are trying to initiate a discussion.

Youth of the same age can vary greatly in physical, mental, social, and emotional growth and interests. These differences are even more marked between age groups. If you are working with a broad age range, the activity may be too simple for the older youth and too difficult for the younger ones. Giving the older 4-H members leadership opportunities can be very effective.

Research has shown that there are some generalities that can help you understand how to plan activities for different age groups.

Early Elementary (Mini 4-H)

This is a very active age, so it is important to keep these children busy. They are concrete thinkers and need to understand what you want them to do and how to do it. They are generally more interested in making something than in completing a project (process is more interesting than product). Youth in this age group tend to seek adult approval and depend upon adults, although the opinions of their peers are beginning to be important. They do best in small groups with set rules and rituals. Competition is inappropriate for this age group.

Upper Elementary

This is also a very physically active age, so hands-on activities work best. Youth in the upper elementary grades are still fairly concrete thinkers (things are black/white or right/wrong), but are beginning to think logically and symbolically. Because this age group has a strong need to feel accepted, it is best for an adult to evaluate each product rather than hold competition among peers with only one winner. This age child likes to know how much they have improved over past efforts and how to improve in the future.

These youth are beginning to identify with peers, but continue to value adult guidance. They are also beginning to discover the benefits of making other people happy, but more for the benefits to themselves rather than the benefits to others. They begin to take responsibility for their actions at this age and begin to develop an increased independence of thought, which may allow them to try new things. Letting this age group help in the decisions of the club helps them start to learn about leadership.

Middle School

Middle school youth are beginning to move to more abstract thinking. Justice and equality are important to this age. (Therefore, project judging may now be viewed in terms of what is fair, as well as being regarded as a reflection of self-worth.) They prefer to find their own solutions, rather than to be given solutions by adults. Try to provide supervision without interference. Independence of thoughts and actions begins to emerge. Avoid comparing middle school youth with each other. Performance should be compared with past accomplishments.

Junior volunteer organizations often are popular with teens toward the end of this age group, particularly if there are opportunities for developing leadership.

High School

Most high school-aged teens know their abilities, interests, and talents. They tend to be very concerned with themselves and their peer group. While they can understand the feelings of others, they tend to be self-absorbed, particularly in the earlier years of high school. Relationship skills are usually fairly well developed. Getting a driver's license increases both independence and dating. Acceptance by members of the opposite sex is very important. High school-aged youth begin to think about the future and make realistic plans. They enjoy career exploration and preparation. Their vocational goals influence the activities they select. Projects requiring research and creativity give teens an opportunity to demonstrate how much they have learned and what they can accomplish. Teens set goals based on their personal needs and priorities. Goals set by others are generally rejected.

As teens master abstract thinking, they may try new ideas in ways that confuse adults. Teens can generally initiate and complete tasks without supervision. A leader can help by arranging new experiences in areas of interest to teens, but must be sure to allow them plenty of input. Assume the role of advisor/coach for independent workers rather than teacher/lecturer. Club meetings, rituals, and uniforms do not generally appeal to this group. But many teens enjoy looking back on their achievements in 4-H and appreciate special recognition for leadership activities. By the time they graduate from high school and begin college or a career, youth feel they have reached the stage of full maturity and expect to be treated as such.

Some Final Thoughts

These guidelines only give a brief overview of child and youth development. They are intended as a resource to help you plan your activities as a volunteer leader. The publication, *Ages and Stages of Child and Youth Development*,* has more in-depth information. You are a valuable asset to your community and to the members of your club. The guidelines for the stages of child and youth development, in combination with your special skills and interests in youth, will help you plan and carry out a successful 4-H program and make a positive impact on the lives of young people.

* *Ages and Stages of Child and Youth Development, A Guide for 4-H Leaders, NCR 292*

Real Colors Training

Many counties have shared the *Real Colors* training to help 4-H members learn about interacting with people who see things differently than them. This program is intended to help youth identify their own personality style and that of others. Understanding personality types helps with effective communication and building positive relationships. The *Real Colors* system is based on temperament theory. Temperament theory is a methodology for helping people understand human behavior. It helps people recognize, accept and learn to value the differences in others. It is a tool to increase understanding, empathy, and communication by reducing prejudice, and bigotry. *Real Colors* training combines experience-based research with a dynamic and entertaining approach that is informative, insightful, understandable and easy to apply in everyday life. The goals of *Real Colors* training is to help youth:

- Understand and appreciate their own personality style and the styles of others,
- Identify temperament of youth and/or adults and help them understand their temperament
- Communicate and interact more effectively with others based on their temperament
- Speak the language of the listener
- Listen in the language of the speaker
- Enhance the participants' ability to understand how others process information
- Improve interpersonal relationships

The *Real Colors* training will show you how to identify your dominate “color,” the relationship with your other “colors” and other people. The four “colors” are:

Solid Gold – sensible, practical, organized; stable and dependable by nature

True Blue – peaceful, sincere, spiritual; nurturing by nature

Curious Green – complex, curious, abstract; non-conforming by nature

Action Orange – immediate, generous, witty, spontaneous; fun-loving by nature

“Everything that irritates us about others can lead us to an understanding of ourselves.” Carl Jung

Talk to your county 4-H Youth Extension Educator if you are interested in offering this program to 4-H members. A number of Purdue Extension staff are certified to teach this course. There is a charge of about \$23.25/participant (2020) for the *Real Colors* materials and there may be a charge for travel costs.

Determining Eye Dominance

(Adapted from the article from the National 4-H Shooting Sports Instructor manuals)

Most people have a dominant eye, just as they have a dominant hand or foot. When a person looks at an object with both eyes, the dominant eye aligns directly with the object unless an obstruction interferes with a clear line of sight. Under normal conditions, when a finger is pointed at an object, or two or more objects are aligned visually, the dominant eye determines the alignment. Just as some people are truly ambidextrous, a very small number of people have indeterminate eye dominance. The majority, however, have a dominant eye. In most cases eye dominance and hand dominance are on the same side, but many people are cross-dominant. That is, their handedness and eyedness are on opposite sides.

Humans have binocular vision -they get slightly different images from each eye and blend them in the brain to yield one image and a sense of depth or distance. With both eyes open, you have a wider field of vision with more peripheral vision and better motion detection. In short, you simply see better when both eyes are used. Experience shows that shooting skills are learned more easily and often better developed when a shooter learns from the dominant eye side. Where eyedness and handedness are on the same side, new shooters easily use the dominant side. Cross-dominant shooters have a greater challenge, but they do better when they learn to shoot with the dominant eye.

Some shooters, particularly those with successful experience in shooting with the non-dominant eye, are reluctant to switch. The switching process usually involves a brief period of reduced success and frustration, followed by improved skill levels beyond their original level. Some experienced shooters have learned to shoot one-eyed closing the dominant eye or obstructing it with a shield, blinder, spot of tape or a small object on the lens of the shooting glasses. Others have learned to override their dominant eye through practiced concentration or to compensate in some other fashion. Less than 1 percent of all shooters must shoot one-eyed because of dominance switching. In most cases, the shooter learns to use both eyes and shoot from the dominant-eye side. Learning one-eyed or with the dominant eye obstructed or closed increases stress and fatigue, and reduces concentration and quickness. Results indicate reduced performance levels, increased frustration for the shooter and slower learning. Learning to shoot well is a challenge. You need every advantage to meet that challenge effectively. Learning from the dominant-eye side is a major advantage.

How to Determine Eye Dominance

Four basic methods for determining eye dominance are described. Those that provide a check for "cheating" are more effective in an instructional setting. Regardless of the method selected, the exercise should be repeated several times. Instructors should remain alert for eye-dominance related problems with shooting performance.

Coach-pupil Method

Shooters should get into coach-pupil pairs, standing several arm-lengths apart and facing each other squarely. The "pupil" should place one thumb over the other, then cross the fingers of the top hand over those of the bottom one.

This leaves a small, triangular opening. Raise the hands, keeping both eyes open, and center the "coach's" nose in the triangular opening. Then the "pupil" should bring his or her hands slowly back to the face, keeping the "coach's nose" in the opening. The hands should come to the dominant eye. Coaches must watch closely for wavering between the eyes, an indication of "cheating" or forcing the hands to a predetermined eye. The exercise should be repeated several times to confirm the original results with both partners checking their eye dominance.

Option: Shooters could cup their hands together, leaving small openings between the bases of the little fingers and the thumbs. A card or a sheet of notebook paper with a small hole centered in it could also be used.

Distant-object Method

Use any of the methods of making an aiming device outlined above.

Center a distant object in the opening. Make sure both eyes stay open and face the object squarely. Without losing sight of the opening, bring the hands, card or paper to the face. The aiming device will come to the dominant eye.

Finger-point Method

With a pointing method, a distant object or a partner is used. The finger is pointed naturally at the object with both eyes open and the face square to the object. The eyes are covered or closed alternately. When the dominant eye is closed or covered the finger appears to jump away from the original location.

Tube Methods

Kaleidoscopes, toilet paper tubes and similar objects can be used with many young people to determine eye dominance. When the person is not aware of being tested for eye dominance, the tube will almost always be brought to the dominant eye. This also occurs with spotting scopes, telescopes and similar tools where one-eyed viewing is needed.

Troubleshooting for Coaches and Instructors

Some shooters will bring the opening back to their own noses because they are looking at the paper or their hands rather than at the target. Those who use the finger-point method will see two fingers if they focus on their hand rather than on the target. If inconclusive results are obtained, try another method. Make note of that shooter, however, and watch for evidence of switching dominance in the act of shooting. Consistently missing to one side of the target usually indicates an eye-dominance related problem.

A Note of Caution: Vision problems can have a serious impact on shooting ability. Often they go undetected by the shooter or those around them. Unless you are an ophthalmologist or optometrist, avoid "diagnosing" vision problems, but be aware of the types of problems a shooter with vision problems may face. Discuss any potential problems you observe with the shooter and his or her parents. Like teachers who notice reading problems or other vision related difficulties, the shooter instructor may notice things that even the shooter misses.

Eye Protection: Be sure that all shooters are wearing adequate eye protection while they are on or near the firing line. We recommend the use of shooting glasses for all shooters, including archers. Eyes are precious and vision is vital to shooting. Let's do our part in protecting them.



Does 4-H Make a Difference?

A New York 4-H member survey found that **4-H club members scored higher on all developmental assets** tested than youth with other club participation or without club participation. The type of 4-H club was not important.

Indiana 4-H Alumni Report

Does 4-H make a difference in the lives of youth? 91% of Indiana alumni agreed or strongly agreed when asked this question.

They reported that the primary impacts of their 4-H participation were:

- Life skill development
- Educational and career influences
- Enhanced family relations
- Program aspects that provided the most impact:
 - Opportunities to compete
 - 4-H Projects
 - Awards and prizes received
 - Other Members
 - Adult 4-H Leaders
 - 4-H Trips
 - 4-H Club meetings

Characteristics of Effective Youth Development Programs

- Youth as resources
- Caring adults and safe environments
- Belonging, with rules
- Flexible and responsive
- Long-term experiences and relationships
- Real work and real responsibility
- Experiences resulting in product or presentation

National 4-H Study of Positive Youth Development (longitudinal study conducted by Dr. Richard Lerner at Tufts University)

When compared to other youth, young people involved in 4-H:

- Are 2.3 times more likely to exercise and be physically active
- Have had significantly lower drug, alcohol and cigarette use than their peers
- Report better grades and are nearly two times more likely to plan to go to college than others
- Have higher educational achievement and motivation for future education
- Are more likely to pursue future courses or a career in science, engineering, or computer technology.
- Are more civically active and make more civic contributions to their communities

Essential Elements of 4-H

There are four essential elements of all 4-H programs. They are:

- **Belonging:** feeling a part of a supportive community.
- **Mastery:** having opportunities for success, the source of self-esteem.
- **Independence:** learning self-sufficiency and responsibility.
- **Generosity:** gaining a feeling of purpose and usefulness.

Belonging

Positive Relationship with a caring adult * An inclusive environment * A safe environment

How can we help youth feel they Belong?

- Encourage peer group cohesion (ice breakers, games, social time);
- Encourage cross-age linkages, adult-youth bonding;
- Modify teaching strategies to enhance sense of belonging;
- Encourage ties with family and community;
- Make small group time available to allow the development of close relationships with peers and staff;
- Encourage collaborative and cooperative learning;
- Show respect for the value of diverse cultures;
- Provide multiple opportunities for youth to develop relationships with adults;
- Encourage supportive peer relationships.

Mastery

Engagement in Learning * Opportunity for Mastery

How can we help youth achieve Mastery?

- Mix hands-on activities with paper and pencil exercises to build job and vocational skills.
- Supplement competition with cooperative activities or games to develop interpersonal skills and self-management.
- Focus on the long-term goals of learning; provide prompt feedback; model and teach that failure and frustration are learning experiences.
- Include communication and basic content skills.
- Teach life skills (money management, decision making, etc.).

Independence

Opportunity to see oneself as an active participant in the future * Opportunity for self-determination

How can we help youth gain Independence?

- Allow youth to make decisions whenever possible and provide opportunities for them to take responsibility for meeting obligations;
- Include youth in planning discussions and encourage input;
- Focus on decision-making rather than obedience; ask youth to do something, instead of telling them to do it;
- Give youth responsibility to carry out tasks, with minimal reminders;
- Do not deprive youth of the thrill of overcoming an obstacle - don't jump in too quickly to help;
- Commend youth who recognize the limits of their independence and seek counsel;
- Share power with young people through self-governance in significant areas.

Generosity

Opportunity to value and practice service for others

How can we help youth develop Generosity?

- Offer mentoring/tutoring programs for cross-age linkages, service projects and community service.
- Tie learned skills/abilities to how they can be used in positive ways.
- Respect and encourage bonds of friendship among young people and between adults and children.
- Use as many opportunities as possible to encourage young people to imagine the feelings of others.
- Highlight the effect of a young person's behavior on others (both positive and negative), reinforce gestures of caring and concern, and ask young people to take responsibility.

Experiential Learning

Experiential learning distinguishes 4-H youth development education from many formal educational methods. Activities are designed so youth experience a learning activity, reflect on what they did (explore the meaning of the activity), generalize what they learned (to test the 4-H members' comprehension and appreciation of the activity), and then think about how they can apply what they learned to other situations (generalize). You can help guide youth as they explore each activity by discussing statements and questions that address these areas (Experience, Share, Process, Generalize, and Apply). Below are some suggested questions you might ask youth to help them with each step.

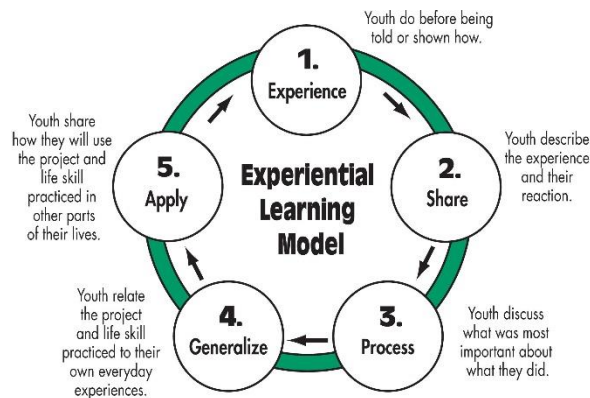

Pfeiffer, J.W. & Jones, J.E., "Reference Guide to Handbooks and Annuals"
 © 1983 John Wiley & Sons, Inc.
 Reprinted with permission of John Wiley & Sons, Inc.

Experience an activity.

- Do it!
- Any Shooting Sports activity that you do with the 4-H youth qualifies as the "experience."

Share what you did, what you learned, and what you liked (or didn't like) about the activity.

- What did you learn to do today?
- What was the goal of this activity?
- Were you surprised about.... (how easy, how difficult, how fun, etc.) this activity was?
- How could you practice what you learned at home?
- How would you explain what you did today to your friend or parents?

Process the activity. Discuss what was most important about the activity.

- What do you think was the most important part of this activity?
- What life skill did you learn when doing this activity?

Generalize, to your own, every day experiences.

- How could you use what you learned today?
- How can this activity help you become a better shooter (or citizen or student)?

Apply, share how you will use what was learned (activity and/or life skill) in other parts of their lives.

- What are some other areas where special safety rules and equipment are important?
- Why must safety rules be followed so carefully?
- How can participation in Shooting Sports lead to learning more about our natural resources?

Experiential Learning

The 4-H program has adopted a process that allows youth to first learn by doing before being told or shown how and then process the experience.

- Participants **experience** the activity - perform or do it.
- Participants **share** the experience by describing what happened.
- Participants **process** the experience to determine what was most important and identify common themes.
- Participants **generalize** from the experience and relate it to their daily lives.
- Participants **apply** what they learned to a new situation.

The advantages of using the experiential learning process in group settings include:

- The facilitator quickly assesses youth's knowledge of the subject.
- The facilitator builds on the youth's experience or knowledge.
- The facilitator is a coach rather than an up-front teacher.
- The youth relate the experience to their own lives and experiences.
- Facilitators may use a variety of methods to involve the youth in the experience.
- Youth with many different learning styles can be successful.
- Discussions move from the concrete to the abstract and analytical.
- Youth are stimulated to learn through discovery and to draw meaning from the experience.
- Facilitator and participant learn together in a cooperative way, rather than in a teacher-student relationship.
- Youth work together, share information, provide explanations and evaluate themselves and others.
- Youth take responsibility for their learning.

Family Involvement

(Source: Family Involvement in Elementary School Children's Education, No. 2 in a Series, Winter 2006/2007 and Family Involvement in Middle and High School Students' Education, No. 3 in a Series, Spring, 2007. Harvard Family Research Project, Harvard Graduate School of Education.)

Elementary School Children

Children undergo important developmental changes during their elementary school years. Their reasoning becomes more logical, their attention gets more adaptable, their perspective taking grows more sophisticated, and their reading and math skills blossom. These children begin spending more time outside the home and with other children and adults. Family involvement is critical for elementary-school-age children's learning and development.

Processes of family involvement and elementary school children's outcomes.

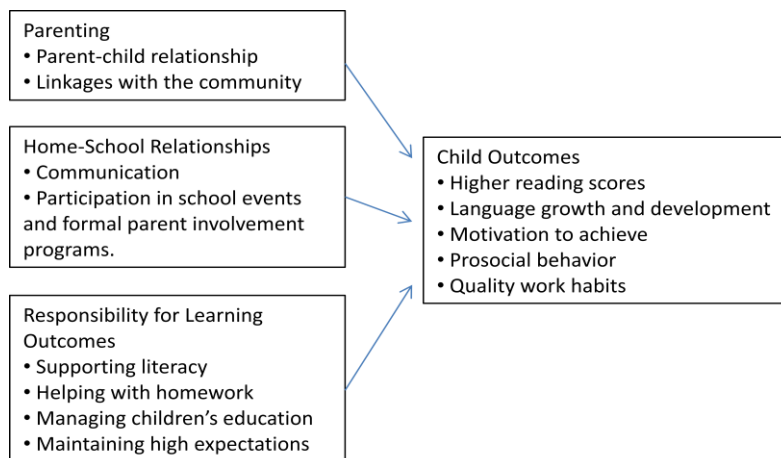

Middle and High School Students

To be successful in school and in life, adolescents need trusting and caring relationships. They also need opportunities to form their own identities, engage in autonomous self-expression, and take part in challenging experiences that will develop their competence and self-esteem. Adolescents desire autonomy, independence, and time with peers, but at the same time, they continue to rely on guidance from parents and other adults.

Process of family involvement and adolescent outcomes

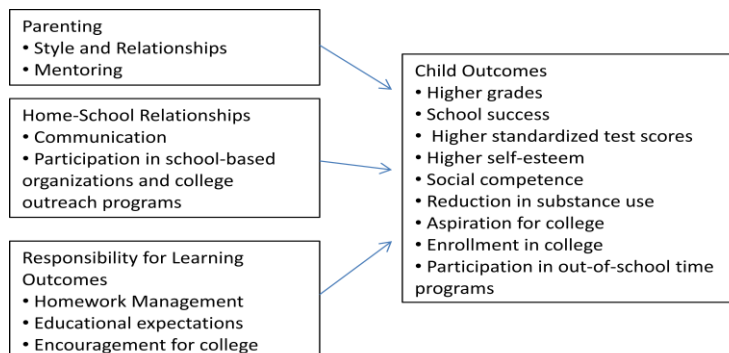

How Do Questions Enhance Performance?

(By Paul M. Whitworth, NRA Shooting Update, Summer, '96)

What's a great tool for motivating and enhancing learning and performance? Answer: Questions! Questions create interest, and stimulate thinking and discussion. When well-asked, they focus attention, check for understanding, and facilitate review. Questions enable participants to use information they have acquired and to receive feedback. Increased use of questions increases participant involvement, and thus, achievement.

Questions serve as icebreakers during introductions. Pair up participants and ask them to interview each other for information such as: participant's name, fishing experience, reason(s) for attending a course, and desired training outcome(s). Subsequent introductions of partners to the group enable attendees to recognize shared backgrounds and experiences. Participants express interests, desired training outcomes, and hesitations or concerns, which the instructor can later reference to minimize resistance to training, generate interest, and increase motivation.

Questions must be clearly and concisely worded. Questions should be asked of an entire group. Then, after a short pause, the instructor can direct the question to an individual. Participants should be given three to seven seconds of "think time." More time may be given if the individual appears to be developing a response. If a response is not forthcoming, the instructor can redirect the question, or restate it.

When asking questions, follow the acronym **APPLE**:

- A** - Ask the question of the group
- P** - Pose the question to an individual
- P** - Pause for participant "think time" (three - seven seconds)
- L** - Listen to the response
- E** - Evaluate the response.

Questions may be closed-ended or open-ended. Closed-ended questions seek a specific, often detailed answer, or a yes or no response. Closed-ended questions limit discussion, and may be used to review, to check for understanding, and to focus or speed discussion. An example of a closed-ended question is: "Can the safety mechanism of a firearm fail?"

Open-ended questions are used to develop discussion and draw out opinions and feelings. Open-ended questions require active thought and promote follow-up questions and discussion. Open-ended questions generally use who, what, when, where, why and how, and allow a variety of responses. An example of an open-ended question is: "How do safe gun handling rules prevent accidents?"

When developing questions, use: "how" and "when" to solicit specifics. Use "what" to gain facts or opinions. "Who" and "where" generate sources. "Why" seeks a cause. Instructors can increase participation by using open-ended questions, redirecting questions for others to answer and relaying additional questions. Relaying and redirecting questions solicits opinions, and avoids instructor provided answers and opinions. Open-ended questions are also useful in party line questioning, in which a question leads to an answer that generates another question.

"Overhead" questions are issued to the group, while "directed" questions are asked of an individual. Addressing questions to the group keeps all individuals involved. Overhead questions are used to introduce topics, generate discussion, and encourage participation. Directed questions are useful to involve non-talkative individuals, stop side conversations,

avoid participants who dominate discussion, and acknowledge individuals who have the answer. Always spread questions equally among the participants.

A check for understanding requires participants to explain, practice and apply new material. Checks for understanding may consist of overhead questions requiring responses by all, a few learners, or an individual (with written or oral responses that the instructor checks privately).

Practical exercises offer excellent opportunities to check for understanding. As an example, many participants recite the correct answer to: "What is a correct sight picture?" However, they may lack understanding. A better check for participants' understanding is to ask: "What does your sight picture look like?" and "Which element is in sharp focus?" Then have them draw a picture of what they observe. Asking participants questions while they perform significantly increases learning, because participants retain 90 percent of what they say and do.

Questions about muscular effort, force, movement, and technique promote kinesthetic awareness of physical efforts and skills, such as for building a shooting position or firing the shot. When shooters perform correctly, resulting in a good shot, ask them to explain how they executed the correct performance and what it felt like. Using their own words allows shooters to reinforce correct performance in a meaningful way.

Initial questions on specifics (e.g., What are the three major parts of a rifle?), when answered successfully, increase student confidence. As discussion continues, relationships may be explored requiring participants to analyze, judge, and compare or contrast options. Higher level questions may follow requiring explanation and justification of answers. Examples of higher level questions are: "Why is the revolver not classified as a semiautomatic?" and "What does Shooting Sports mean to you?"

Questions are used throughout training. Effective instructors use questions to promote active learning and to provide feedback. Questions are invaluable for more meaningful training and learning.

Meeting Activities

The following activities have been submitted by volunteer leaders and youth.

Obstacle Course

Check that your 4-H members understand safe firearm and bow handling in the field with this fun activity:

- Set up or mark an obstacle course containing any of the following obstacles, and others you (or your older members) can think of:
- fence (different heights, if possible)
- gate
- stream
- companions (one walking on the right, one on the left, and one on each side)

Have each 4-H member walk through the course, carrying their firearm or bow properly. Let the other 4-H members critique how well the youth did. Discuss this positively and explain that you expect each member to do even better, as they watch and learn from the members who have completed the course.

Note: Older youth can be very helpful in setting up the course and thinking of obstacles. You might prefer to work with the older youth to make sure that they understand safe gun (and bow) handling over each obstacle and then let them walk the course with the younger 4-H member for a 1:1 teacher:student ratio. After all the youth have walked the course, bring them together to discuss what they learned, what problems they had or could imagine.

Making Animal Tracks

Making plaster casts is fun, interesting, and educational. Casts are easy to make and can be used as teaching aids or display items. Plaster casts are made of specimens you cannot bring home, such as animal tracks.

Steps to making your cast:

1. Locate the specimen you want to use.
2. Make a form by joining cardboard strips to surround the specimen. The strips can be joined with paper clips. Use a paper clip to join the ends of the form. Place your form around your specimen. If there is soil around the specimen gently press the form into the soil to create a dam.
3. Pour enough Plaster of Paris into the mixing cup to fill your form to a depth of about one inch. Add water to the plaster, a small amount at a time, and stir with a stick or spoon until the plaster is smooth, thickened and will pour slowly - about the consistency of pancake batter.
4. Pour plaster into the form to the depth of approximately three-quarters to one inch. If you are making a cast of a track in sand or

Materials Checklist

- Plaster of Paris
- Form - made from the strips of a cardboard milk carton or similar material, cut about 3/4 to 1 inch wide and up to 1 foot long
- One of the following lubricants: Vaseline, kitchen oil or grease, petroleum jelly, shortening
- Mixing cup and stick or spoon for mixing the Plaster of Paris (Plastic containers are desirable because hardened plaster can be easily removed from them by flexing the plastic and the container may be used again.)
- 2 strips of cardboard (a milk carton works well - or plastic strips from a milk jug)

loose soil, pour the mixture down the stirring stick to avoid damaging the specimen. Fill the form nearly to the top to make a stronger cast.

5. Leave the plaster overnight, or longer, if the weather and time permits. Once the plaster has set carefully, lift the cast off the specimen. A knife blade or spatula can be helpful in lifting the cast. Brush the excess soil or debris away after the cast is thoroughly dry.
6. Dry the plaster mold completely. In the middle of the summer, it can be baked in the sun for two or three days. In the winter it may be dried in a slightly heated oven (approximately 100° F for approximately one full day, twenty-four (24) hours).

Blood Trail

The purpose of this exercise is to familiarize the members in tracking wounded game by using a blood trail. In a squirt bottle, mix up 4 ounces glycerin (from Health & Beauty department), 2 ounces tap water and 2 ounces red food coloring (equal parts of water and milk with red food coloring can also work but will turn sour). Add enough red food coloring to make the milky water dark red (to the color of blood). In a wooded area, create a trail using the “blood” that a game animal would follow. Break branches and create areas of matting down to help the trail be more visible and more natural. Whenever the animal could exert itself, for instance jumping over a fence, make sure to increase the amount of blood in that area. Take each member through the blood trail and help the younger members recognize the signs for the blood trail.

Beast Feast

Introduce 4-H members to the taste of different types of game like venison, pheasant, mourning dove, rabbit, elk, and beaver with a Beast Feast. It is also a chance for members of your club to meet local hunters and members of other Shooting Sports clubs. Contact local hunters to see if they are interested in sharing game. There are a variety of ways the game could be prepared, with a stew being the most common. It is a good idea to cook all the food over a fire so members can be exposed to Dutch oven cooking at the same time. Dutch ovens can be used to cook stew, potatoes, breads, and deserts. There are several websites and books devoted to Dutch oven cooking as well as recipes for game.

NRA & NSSF Resources

NRA training materials website: <https://materials.nrahq.org/TrainingMaterials/>

To: State 4-H Shooting Sports Coordinators
From: Chip Lohman, NRA Youth Programs Coordinator

For clubs with a Shooting Sports program or who may be interested in starting one, note that there are several no-cost resources available from the NRA Youth Programs office in Fairfax, VA available for the asking.

These include a listing of local ranges, women's programs, hunting programs, clubs and local classes by zip code, free instructional materials, downloadable competitive rulebooks, grant applications, Shooting Sports camp schedules and the popular Winchester/NRA Marksmanship program. There are also training and certification programs to become a Coach, NRA-Instructor or Training Counselor (teach other teachers). Based on over 130 years' experience in marksmanship and firearm safety, these programs not only improve your skills, but they limit your liability and are the international benchmark for firearms safety.

National Shooting Sports Foundation, www.nssf.org/shooting/

“The trade association for the shooting, hunting and outdoor industry, the National Shooting Sports Foundation works on behalf of its nearly 6,000 industry members to promote, protect and preserve the proud traditions of shooting and hunting in America.”

The website has links to the following topics:

- Where to Shoot
- Targets
- Handgun Sports
- Rifle Sports
- Shotgun Sports
- Organizations
- Youth & College Programs
- New Shooters

Non-Threatening, Hands-on Instruction

(adapted from material developed by Jim Peter, retired Extension Educator, Dubois County CES)

A major element of shooting is stance. When working with shooters, particularly beginners, instructors frequently must use their hands to position the shooter to correct their form. Because close contact with the shooter is often essential for effective instruction, the instructor must be careful to avoid any action that could appear improper or cause the student anxiety. A few simple actions can ensure a working relationship between instructor or coach and student without any question of anxiety or impropriety.

Respectful, non-threatening treatment of shooters begins with demonstration. Ask a junior volunteer or parent assistant to help demonstrate how instructors will work with shooters to correct their posture or position. It is best to discuss and demonstrate how you will reposition shooters at your first meeting and while parents are present. Shooter anxiety levels will be reduced when they know what part of their body is not in the correct stance and how you will be moving it.

Remember IRS:

- 1) **Inform:** Tell the shooter what you are about to do (such as “I am going to reposition your right arm, push your torso forward, raise an elbow, reposition a hand, turn your hips, etc.”). This reduces the shooter’s anxiety because they know what you are doing.
- 2) **Rigid fingers:** Hold your hands relatively rigid with fingers and thumb straight. Except in an unsafe situation where immediate and decisive action is required, it is seldom necessary to "grab" a student or the firearm. Pressure from the palms of flattened hands (fingers not curled) can accomplish most repositioning necessary.
- 3) **Stance:** Move the student into the correct position and ask them if they can feel the difference. Does the new position feel more comfortable?

The student may need to try the new position for a while until they feel comfortable with it. Don’t be surprised if they lapse into old habits - it takes time to develop new habits.

Participation of Fathers

Depending on Dad: Father's Involvement Pays Off

* From the National Update on America's Education Reform Efforts
 This report was taken from Daily Report Card 10/03/97, (c)
 by the Education Policy Network, Inc. Publisher: Barbara A. Pape.

A federal study has shown that children do better in school when their fathers are involved in their schools. This result is seen whether or not dads live with their children as long as their mothers are involved in their education. The study provides data from the National Center for Education Statistic's 1996 National Household Education Survey of the parents of 16,910 kindergarten through 12th graders. It is one of the first bodies of research that examines the individual contributions of mothers and fathers in their children's education.

"This study provides hard evidence about the powerful and positive influence that parents can have as full and equal partners when they make the commitment to help their children get a good education," said Vice President Gore. "Fathers matter a great deal when it comes to helping their children succeed in school and this study should encourage millions of American fathers to step up to the plate and make a difference in their children's education."

According to "Fathers' Involvement in Their Children's Schools," children whose dads are involved in school are more likely to get mostly A's. However, the study found that in two-parent families, fathers are less likely than mothers to be very involved in their children's schools: The proportion of children with highly involved fathers (27%) is about half the proportion of those with highly involved mothers (56%).

Other findings:

- Mothers and fathers are most likely to get involved in their children's schools if the schools welcome parental involvement and make it easy for parents to be involved;
- Fathers of more than half of the K-12 children participate at their children's school at a moderate (two activities per year) or high (three or more activities per year) level;
- Children living in two-parent families are more likely to get mostly A's, regardless of the level of the mothers' involvement. Children who live in single-parent families headed by fathers are twice as likely to get mostly A's if their fathers are highly involved at school, compared with those whose fathers have little involvement;
- In single-parent families, children living with single fathers or single mothers are about equally likely to have highly involved parents -- 46% and 49% respectively; and
- Families with high parental involvement in their children's schools are more likely to visit a library, museum or historical site with their children, and are more likely to have high educational expectations for their children.

Publications

The Indiana 4-H Shooting Sports manual 4-H 950 is introductory. It provides a safety overview (eye and ear protection) and equipment part identification for the disciplines. It also has suggestions for projects and activities for each discipline.

National Shooting Sports Foundation, NSSF, www.nssf.org/

The National Shooting Sports Foundation provides a variety of publications and videos on topics including safety, conservations, and hunting. Some publications are free. See the website, <http://www.nssf.org/>, click on “Safety” or contact the company.

Federal Premium Ammunition, www.federalpremium.com/

Federal Premium Ammunition has a variety of publications and videos are available on topics such as: safety, conservations, and hunting.

Books

Teaching Shooting Sports to Persons with Disabilities (ISBN 0-916682-66-8)

Outdoor Empire Publishing Company Inc.

P.O. Box C-19000

Eastlake Avenue East

Seattle, Washington 98109

Phone: (206) 624-3845

Alan Madison Productions, Inc. www.alanmadison.com/

4-H Shooting Sports Instructors that are certified in Hunting/Outdoor Skills have learned techniques to get the most from the following Alan Madison Productions videos/DVDs. They can do a presentation that would be beneficial for 4-H Shooting Sports youth in all disciplines. Hunter Education (HE) instructors can borrow many of these titles in DVD format from the local CO and many will provide instruction. If you are not a HE instructor and would like to review these resources, contact Tim Beck (TBeck@dnr.IN.gov). The materials may be purchased directly from Alan Madison Productions:

Alan Madison Productions, Inc. PO Box 100 Chatham, NY 12037	1.877.404.3311 518.392.3314 fax www.alanmadison.com
---	--

DVDs

“The 5 Pack” from Alan Madison Productions, Inc.

This set includes:

- ◇ Survival! (21:30 minutes)
- ◇ The Last Shot (14:28)
- ◇ Shoot/ Don't Shoot II (14:33)
- ◇ Firearms Safety & the Hunter (21:23)
- ◇ The Hunters Path.... Choices in responsible hunting (17:56)

August, 2020 price: The set for \$99 plus \$8 for shipping and handling.

Raising Responsible Youth

(Source: Excerpted and adapted from "Raising Responsible Youth – Lois Clark, Ohio State University Extension; in "Family Tapestries: Strengthening Family Bonds.")

Adolescence (between the ages of 13 and 19) is a time of transition during which young people explore and search for independence. As might be expected, the relationship between adolescents and their parents also changes. What can parents do to help teens move safely toward independence and young adulthood?

Love unconditionally. Love and acceptance do not mean parents have to approve of everything their adolescents do, but parents need to accept teens for who they are, not what the parents want them to be.

Be proud. Teens want and need approval and want to know their parents are proud of them. Show appreciation for the positive things adolescents do.

Praise appropriate behaviors. Genuine praise can be effective because teens are more apt to repeat a behavior that pleases a significant person.

Be involved. Adolescents need their parents to be involved in their lives. Parents need to be available when teens need them; parents are still important in the life of an adolescent.

Talk each day. With today's busy lifestyles, it may seem impossible to find a time to talk when parents and adolescents can give each other their undivided attention. Try to create times to talk each day. It may not be long-perhaps just five minutes. But, keep the communication lines open.

Be observant. If the parent sees the adolescent is not feeling good about something, acknowledge the teen's feelings. Listen to what is being shared. Avoid offering a "pat" solution or quick judgments.

Guide and advise. Parents can help adolescents explore and clarify issues and the consequences of actions through discussion. Assist them in exploring the pros and cons of issues.

Establish boundaries. Adolescents need and want limits. Limits need to be clear, reasonable, age-appropriate, and change as the youth moves through adolescence. Parents can involve teens in the determination of limits; however, it is the parents' responsibility to set and consistently enforce the limits.

Parents may need to say "no." A parent's reasons for saying "no" need to be logical. Parents should remain calm and not change their minds.

Recognize limits will be tested. Recognize that rules will be broken; help adolescents to accept responsibility for their own behavior.

Build trust. Trust adolescents to do the right things. Teens earn a parent's trust by doing the "right things," such as respecting their curfew.

Use fair consequences. When a limit is not followed, a consequence follows. Consequences are effective only if they are meaningful to the adolescent.

Model appropriate behavior. Adolescents can learn appropriate life skills as well as how to solve problems effectively by watching parents and adults.

Monitor behavior. Parents should know where teens are, what they are doing, and whom they are with.

Parenting takes time and effort. Over time teens will appreciate the changes that have occurred on their path to responsible adulthood.

Shooters with Disabilities

Include youth with special needs to the best of your ability. Talk with the parents to determine what needs the youth has, how they can best be addressed, and if extra help is required. It can be both appropriate and reasonable in some cases to ask the parent or guardian to be present and involved with their child at shooting sessions to help with mobility challenges or to provide an extra set of eyes, if closer observation is required.

The passage of the Americans with Disabilities Act of 1990 brought to the forefront the needs and rights of individuals with disabilities. The Act guarantees equal opportunity in employment, in public accommodations, in transportation, in state and local services, and in telecommunications for persons with disabilities. Youth with disabilities especially benefit from the many opportunities ensured by this Act.

Approximately 4.3 million school-aged children in the United States have disabilities. Great strides have been made in our formal education system to educate these children, but efforts need to be made to ensure that children with disabilities also have the opportunity to participate in non-formal education programs, such as 4-H.

4-H Is for Everyone

The mission of 4-H is to help youth in their development through hands-on learning. It is important that those involved with 4-H be well-informed about disabilities and their implications for 4-H involvement. This awareness allows 4-H to remove any possible participation barriers, to better structure programs and activities that meet the needs of these young people, and, most importantly, to nurture and encourage youth from all backgrounds. Efforts must be made to step up the process of informing the public that 4-H is open to all youth including those with disabilities and that the concept of mainstreaming is an active part of current 4-H programs.

Reaching Children with Disabilities

4-H must make sure that all children have the opportunity and are encouraged to participate in 4-H. It is our responsibility as adults to ensure this occurs by recruiting 4-H members through non-traditional avenues. Potential ways of recruiting youth with disabilities include the traditional contacts through schools and churches, but volunteers also should contact local rehabilitation service agencies and parent support groups. Other agencies that may provide assistance are March of Dimes or Easter Seal offices.

Benefits of Mainstreaming

All 4-H members grow as people by focusing on strengths, developing more positive attitudes, and removing prejudices, while attaining a greater sense of achievement and positive self-image. Direct benefits of mainstreaming youth with disabilities into 4-H programs include:

- 4-H members with disabilities can develop a greater sense of self-confidence and self-reliance as they interact with others in an encouraging environment.
- 4-H volunteers have the opportunity to learn new skills and techniques for working with children. Volunteers can broaden personal experiences and become more accepting of people who are perceived to be different.
- 4-H members without disabilities have an opportunity to interact with youth whom they perceive to be different. Members learn that all people have strengths and weaknesses. They learn to see a person for his/her unique abilities and not for the disability.

Disabilities

Disabilities encompass a wide range of social, physical, mental, and emotional conditions. Disabilities affect all segments of the population and come in many forms. Some of the most common physical disabilities are:

- amputations
- neurological impairments such as cerebral palsy, epilepsy, spina-bifida
- vision impairments such as blindness
- musculoskeletal impairments such as paralysis, muscular dystrophy, arthritis
- hearing impairments such as deafness
- respiratory impairments such as asthma, bronchitis, emphysema
- congenital malformation - birth defects such as dwarfism, malformed body parts
- diabetes
- developmental disabilities
- emotional disabilities

These are only a partial listing of disabilities. There are many others that may affect young people. Your local school system can help you to plan an appropriate program for challenged youth in your program. Try to include all youth while continuing to maintain the highest standards of safety. A reference you may find useful is:

Teaching Shooting Sports to Persons With Disabilities ISBN 0-916682-668, Library of Congress Number 93-49380, Outdoor Empire Publishing, Inc., Phone (206) 624-3845

The NRA offers support and guidance to organizations. To obtain more information about any of the various programs offered or to ask specific questions about adaptive shooting activities and/or problems, call or e-mail the NRA Adaptive Shooting Program, (703) 267-1491, <https://adaptiveshooting.nra.org>, e-mail: Adaptiveshooting@nrahq.org.

Youth and Violence

Youth and Violence: A Report to the Nation

(From the report of the American Medical Association, December 2000)

Note: The following information and quotes and notes from the AMA Youth and Violence report.

Critical Influences of Youth Violence

“A youth does not pick up a gun and shoot a classmate or rape a neighbor solely because he or she watched too much violent television or was abused at home or suffered racial injustice or could not read. A single event may set off the explosion but the charges were laid over time as a result of the interaction of multiple individual, situational, contextual, and societal influences. Risk factors for violence and aggression are additive and follow a developmental sequence; this is why programs designed to diminish them must be developmentally appropriate. Risk factors are also interdependent and are affected by a range of life experiences and influences involving family, peers, community, and culture, as well as an individual’s personal physical and mental health status.”

Critical Influences:

Behavioral influences – most children and adolescents who engage in violent behavior have pre-existing emotional, cognitive, neurodevelopmental, and/or psychosocial problems. They may have suffered a recent loss, disappointment or rejection; felt alienated or disenfranchised; experienced academic failure; or fallen into alcohol or other drug abuse. For some, the early onset of aggressive behavior in childhood puts them at increased risk for delinquent behavior and criminal involvement later in life. Most serious juvenile offenders have a history of childhood misbehavior, including antisocial behaviors such as physical aggression; conduct disorders; and disruptive, covert, oppositional, and defiant behaviors.

Biological influences – Forty-three percent of juvenile murderers in one study suffered past serious head trauma, which may have contributed to the murderous behavior. Brain damage can result from emotional as well as physical blows. Scientists have shown that, as late as school age and even into adolescence, exposure to a single extreme situation of violence can change the structure and function of the brain in ways that are likely to interfere with academic performance. Research indicates the important role of certain brain chemicals, especially the neurotransmitters serotonin and noradrenaline in regulating aggressive behavior; it also suggests that negative experiences in early childhood, particularly severe neglect and abuse, can cause long-lasting changes in the levels of these chemicals in some individuals.

Economic influences – A quarter of all young children in the United States live in poverty, including 37% of all African Americans and Hispanics under age 18 and 16% of white children. Numerous dimensions of poverty relate to high rates of community violence, including high levels of transience and unemployment, crowded housing, low levels of community participation and organization, firearm and drug distribution networks, increased school dropout rates, alcohol and other drug abuse, unemployment, and teen pregnancy. In all ethnic groups, rates of violence are highest for boys and men at the lowest economic level. At any given economic level, few differences are found among racial groups.

Societal, familial, environmental influences – These factors include bigotry, intolerance, and injustice; easy access to weapons, alcohol and other drugs; exposure to violence in the family and community; poor schools; and lack of opportunities for children to engage in purposeful, positive, supervised activity outside of school. Also included in this sphere, is the rampant violence that bombards children from video games and television, and from movie and computer screens. Family violence has been said to be the training ground for youth violence, the breeder of hate. Less obvious but just as critical is inadequate parenting: failure by parents to set clear expectations for their children; failure to supervise and monitor their children’s behavior; and excessively severe, overly harsh, or inconsistent parenting. Family risk factors also include mental illness in the family, abuse of alcohol and other drugs by family members, large family size, stressful life events, family disorganization, and poor parental bonding. Many adolescents spend up to 40% of their non-sleeping time alone or with peers or adults who might negatively influence their behavior. Low-income youth are more likely than others to be home alone for three or more hours after school – which is the same time during which most juvenile violent crime is committed. Youth who embrace the culture of violence are most likely to feel socially disconnected, with no stake in society, no sense of a productive future, and no trust in adults.

Key Risk Factors

Research indicates that a number of factors increase the risk of violence during childhood and adolescence. Risk factors are complex and interdependent and can be influenced by multiple variables, individual and societal. This report highlights six key risk factors:

Alcohol and other drugs (60% of domestic violence incidents involve an offender who is drinking; in the United States, 40% of students who drank alcohol at school also carried a weapon at school compared with 4.4% of those who did not drink)

Child maltreatment - The National Center on Child Abuse and Neglect recognizes six major types of child maltreatment: physical, sexual, and emotional abuse and physical, educational, and emotional neglect.

- “In 1997, almost 300,000 children in the United States were the subject of confirmed reports of abuse and over half a million more were found by child protective agencies to be neglected.”
- Unreported incidents of maltreatment are estimated to be as high as three million a year.
- In 60% to 75% of families in which a woman is battered, children are also battered.”
- Many parents would be surprised to find that spanking has the identical effect on children as child abuse, although with lower frequency. In one high-crime neighborhood, youth whose fathers used corporal punishment on them (and a quarter of 16-year-olds are hit by their parents, nationwide) were more likely than other youth to be convicted of a serious crime (34% vs 14%). While approval of spanking has dropped from 96% to 54% over the last 30 years, 94% of parents still spank toddlers; while 34% of parents admit to hitting an infant under age one.

Gangs – Youth gangs are responsible for a disproportionate share of all criminal offenses, violent and nonviolent. A quarter of rural areas, a third of small cities, and 57% of suburbs now report active gangs.

Guns – The rise in murders of juveniles from the mid-1980s through the peak year of 1993 was entirely firearm-related, as was the subsequent decline in juvenile murders through 1997. In many parts of the country, firearms have surpassed auto crashes as the leading cause of death among children and youth. In fact, homicides involving firearms have been the leading cause of death for black males aged 15 to 19 since 1969, and teenage boys in all racial and ethnic groups are more likely to die from gunshot wounds than from all natural causes combined. “Since 1889, 223 million firearms have been produced in or imported to the United States. An estimated 192 million guns are in private hands today; at least 25 million households keep handguns and 50% of their owners keep them loaded. Handgun owners typically cite self-defense to justify this practice, but suicides, homicides, and accidental deaths in the home outnumber deaths associated with self-defense by 40 to 1. Family and friends are the primary sources of guns for young people; only 5% have asked someone else to purchase a gun for them for legal or illegal sources.”

Media violence – The average child views about 25 acts of violence a day on television, or some 200,000 such acts (including more than 16,000 murders) by the age 18. According to the Federal Trade Commission, movie studios, record companies, and video game producers are actively marketing violent entertainment products to children. “Studies of the effects of TV violence suggest that children confronted incessantly by violent images in the media may:

- become immune to the horror of violence
- come to accept violence as a way to solve problems
- imitate the violence they observe
- identify with victims or victimizers in unhealthy ways

“Children are certainly affected by the massive coverage given by news media to sensational violence, including incidents of mass murder/suicide, which may trigger copycat behavior in some children and adolescents.”

Violence among intimates and peers – The effects of witnessing domestic violence, even among very young children, can include traumatic stress reflected in higher levels of depression and anxiety, attention and learning problems, and greater likelihood of developing aggressive and anti-social behavior. Between 10% and 30% of teens experience violence while dating, which is not surprising in view of a survey in two Chicago high schools in which 28% of boys responding believed that “girls needed to be punched or slapped sometimes.” One in seven school children is either a bully or victim of a bully, one of the distinct warning signs of youth violence.

Warning signs of youth violence

Many children and youth who behave violently have a long history of emotional and behavioral problems. Signs and symptoms of trouble usually have existed for years, not as isolated behaviors or single emotional outbursts. Consultation with a mental health professional should be considered for children who display behavior patterns incorporating one or more of the following signs:

- frequent loss of temper
- frequent physical fighting
- significant vandalism or property damage
- making serious threats
- extreme impulsiveness
- alcohol and other drug abuse
- easily frustrated
- hurting animals
- preoccupation with violent or morbid themes or fantasies in schoolwork, artwork, or choice of entertainment
- carrying a weapon
- name calling, abusive language
- bullying or being bullied
- truancy

- excessive feelings of rejection, isolation, or persecution
- gang affiliation
- depression, despair
- low self-esteem
- threatening or attempting suicide
- extreme mood swings
- deteriorating school performance
- being witness to or the subject of domestic abuse
- setting fires
- preoccupation with weapons and explosive devices
- history of discipline problems
- social withdrawal
- blaming others for difficulties and problems

Note: These indicators are not necessarily reliable precursors or predictors of violent or delinquent behavior. They must be interpreted carefully and cautiously to avoid the risk of unfairly labeling and stigmatizing an individual. Just as important as responding to early warning signs is not over-reacting, in what US Secretary of Education Richard W. Riley called "mechanical profiling of students" Stereotyping and labeling can have devastating and indelible effects.

The Indiana 4-H Program

Traditions, System Structure, Policy

4-H Emblem: A green four-leaf clover with a white letter “H” on each leaflet. The four ‘H’s represent the four-fold development of Head, Heart, Hands, and Health.

4-H Pledge:

I pledge
 My Head to clearer thinking
 My Heart to greater loyalty
 My Hands to larger service, and
 My Health to better living,
 For My Club, My Community, My Country, and My World.

4-H Slogan: Learn By Doing

4-H Colors: Green and White

4-H Motto: To Make the Best Better



System Structure

Local 4-H Club – the basic unit of 4-H. The club, or group, provides the unit for members to enroll, become active in 4-H related activities, and be a participant in a group’s planned program of meetings, demonstrations, tours, visits, etc. The club relates to its school, township, or county organization through its Junior and Adult Volunteers, who receive special training. The representative “voice” of the local 4-H community is provided by members of the County 4-H Council.

Volunteers provide invaluable support as 4-H Club Leaders, project leaders, members of county Extension boards, county 4-H councils, county 4-H Fair board, and numerous other support committees. These dedicated volunteers are the core of any local 4-H club. Generally, the county 4-H council provides local policy, program leadership, and direction for the 4-H program, in conjunction with the 4-H Youth Development Extension Educator. Typically, a 4-H council will include committees that give special leadership to: 4-H program planning, 4-H finance and resource development, 4-H awards, achievement, and volunteer training. The Fair board gives leadership to the county fair and all the activities associated with the fair. The fair provides a showcase for member projects and activities to be displayed for the public to share. 4-H projects are often judged so that 4-H members can learn how to improve their work.

County staff – The county 4-H organization includes a limited number of salaried staff in addition to the large number of volunteer staff who direct and give leadership to the county 4-H program. The salaried staff is a group of professional Purdue Extension employees with training and skills in the areas of agriculture, health and human sciences, community development, and youth development. The **4-H Youth Development Extension Educator** is responsible for providing volunteer training and coordination to the 4-H program with team assistance from other county Extension staff and state staff.

Policy Guidelines – The 4-H policy guidelines must be followed by employees and volunteers alike.

Civil Rights and 4-H

- 4-H Programs at all levels must comply with the Civil Rights Act of 1964. This act requires that all persons shall have equal opportunity and access to the programs and facilities without regard to race, color, sex, religion, national origin, age, marital status, parental status, sexual orientation, or disability.
- You must make every reasonable effort as a 4-H volunteer to see that this equality of opportunity is maintained fairly.
- You should be able to report on ways that you used to be sure that 4-H was equally open to all youth in your community.

Expenses for Volunteers

- You may be able to deduct out-of-pocket expenses for 4-H work from your federal income tax return (pending consultation with your tax advisor), if you are not reimbursed by your local or the state Extension office. This usually includes money spent for fees, materials, awards, travel (meals, lodging, cost of transportation).
- You must keep a record of expenses for your tax return. Show the date, nature and amount of cost, and miles traveled. Canceled checks and receipts will be needed. Check with your professional tax advisor for further details.

Insurance for Volunteers

Purdue University carries general liability insurance coverage. The University, its employees, and its volunteers are covered while acting within the scope of their duties.

The Indiana 4-H program also provides volunteers with limited accident/injury insurance coverage for incidents that occur as a part of their participation in the 4-H program. Please note that few other states extend this coverage to their volunteers.

If an accident happens...

- A homeowner/landowner's insurance is primary.
- Purdue provides coverage for bodily injury or personal injury to third parties.
- This includes damage to their property when such injury is the result of Purdue's negligent act.
- Report the accident/incident immediately to the 4-H Youth Extension Educator.

Personal injury can include:

- Defamation of character
- Invasion of privacy
- False arrests

4-H members' names and addresses Youth names and addresses are protected and must not be distributed to individuals or organizations beyond the 4-H Program.

Philosophy and Expectations

Note: Selected sections of the policy are given below and intended to be used for reference purposes only. The County 4-H Youth Extension Educator is your first point of contact when you have questions about the 4-H program.

The Indiana 4-H program serves the youth of Indiana by providing a strong educational youth development program. This program delivers educational experiences in a variety of settings. Caring, capable and contributing adults assist in the 4-H program as models for youth. The rich heritage of the 4-H Program is one to be valued and passed along to future generations.

The Indiana 4-H Youth Policy and Procedures Handbook includes certain standards and guidelines to be used to assure that 4-H is a positive youth development program. County 4-H policy is guided by the county 4-H policy making or governing board (i.e., 4-H Council) as provided by the County Extension Board. Legal authority for the 4-H Program rests with the Director of Purdue Extension. No county 4-H policy may conflict with state 4-H policy or with federal guidelines and requirements.

Deadlines for county and state participation should be carefully constructed so as to encourage rather than to discourage participation. Such deadlines should be well published. Members not complying with established and published dates and deadlines for exhibition may be denied the opportunity to exhibit.

It is the policy of 4-H to be an inclusive organization. No county policy or practice should be used to arbitrarily exclude youth from either membership or participation. Youth should participate in 4-H Youth Development opportunities at levels and times that best suit the youth's development and support family involvement.

Membership: Youth may become 4-H members when they enter the third grade and may continue their membership through the completion of grade 12. A member may continue membership for a maximum of ten (10) years. An individual's 4-H grade is determined by the school grade in which he or she is classified regardless of the time of year he or she enrolls in 4-H. A member does not advance in 4-H grade until he or she enrolls in 4-H for the subsequent school year. Each member should enroll in the division of a project that would best suit his/her interest and potential for personal growth and would enhance their family involvement.

Opportunities in the 4-H program are available to all Indiana youth as defined regardless of race, religion, color, sex, national origin, marital status, parental status, sexual orientation or disability. Married young men and women of 4-H age may participate in any of the 4-H projects and activities. However, married persons must participate by the same terms and conditions and/or guidelines as unmarried participants. Membership in 4-H is gained by annually enrolling through a Purdue Extension Service Office located in each of Indiana's 92 counties.

The 4-H club year usually extends from one annual 4-H exhibit to the next. Enrollment is an annual process attained by completing the appropriate county 4-H enrollment process.

Residence: Indiana youth typically enroll in 4-H in the county or state in which they reside. However, individuals living in one county **may** join 4-H in another county. There may be educational or social reasons for an individual joining 4-H in a different county than that of their primary residence. During a single calendar year, a 4-H member enrolled in a given project is expected to enroll and exhibit that project only in one county of enrollment. In the event that a project is not offered in the county of primary 4-H enrollment, a 4-H member may enroll in that specific project in a different county. Approval of this special exception rests with the 4-H Extension Educator. Participation in 4-H related activities and events (i.e., judging, share-the-fun, auction) must be in the county of primary 4-H enrollment. The above policy is not intended to provide an escape mechanism for troubled 4-H members and families who are unwilling to follow the terms and/or conditions in their current county of

4-H membership. Decisions regarding 4-H membership in a non-resident county (a county you do not live in), rest with the 4-H Extension Educator in the receiving county. Note: In a statement from our federal partner in Washington, DC, the following statement appears: *"Anytime there are procedures for exclusion of individuals from events which use the 4-H name there are potential challenges to enforcement of the exclusions. The challenges have a substantial potential to prevail and they frequently result in negative publicity for the organization. Therefore, before choosing a policy of exclusion it is wise to evaluate the exclusion being considered, to be sure there is an overwhelming educationally based need for the exclusion"*.

Deadlines: Deadlines for county and state participation should be carefully constructed so as to encourage rather than to discourage participation. Such deadlines should be well published. Members not complying with established and published dates and deadlines for exhibition may be denied the opportunity to exhibit.

Exhibition: Exhibition of 4-H projects in local, county, or state exhibits/fairs is voluntary on the part of the exhibitor, and may be virtual or in person. The exhibition of 4-H projects provides 4-H members an opportunity to display their 4-H projects, enter into competition and participate in an educational/social environment with peers. With exhibition also comes the responsibility for abiding by all the terms and conditions pertaining to the respective 4-H project.

Completion: The completion of a 4-H experience may include a variety of options and must not be misinterpreted as exhibition of a project at a local, county or state fair. There are a number of ways that a young person may participate in the 4-H Youth Development Program in addition to the club-based option. Participating in these 4-H opportunities enable the youth to build skills that will serve them well throughout their adult lives. 4-H members are considered complete in their educational experience for that year when they have:

1. Completed the "official" 4-H member enrollment process prior to the established and published date for enrolling
 2. Had an officially recognized 4-H volunteer/extension educator verify the existence of the completed project or member's participation in a 4-H educational experience.
- Additionally, 4-H members who participate in a club- or fair-based 4-H project will submit a completed 4-H record sheet based on printed or web-based educational materials used by Indiana 4-H prior to the established and published date

Though exhibiting in local, county, and state exhibits/fairs is not required for project completion, as it does not necessarily relate directly to content and skills learned in the development of the 4-H project, project exhibition is encouraged as a continuation of the educational experience.

Behavioral Criteria: 4-H members, volunteers, parents and the public: When attending, participating or acting on behalf of the 4-H program, all persons are expected to conduct themselves in accordance with accepted standards of social behavior, to respect rights of others, and to refrain from any conduct which may be injurious to the 4-H program. The following actions constitute misconduct for which persons may be subject to disciplinary penalties and/or dismissal from the program:

- Dishonesty in connection with any 4-H activity by cheating or knowingly furnishing false information
- Alteration or unauthorized use of 4-H records
- Obstruction or disruption of any 4-H activity or aiding and encouraging other persons to engage in such conduct
- Failure to comply or aiding or encouraging other persons not to comply with specific terms and conditions of a given project, contest, or activity
- Failure to comply with directions of 4-H officials acting in the proper performance of their duties
- Inhumane treatment of animals

Adult Behavioral Expectations Adult Behavioral Expectations give faculty, educators, staff and volunteers the opportunity to reaffirm their commitment and dedication to the well-being of young people. When all faculty, educators, staff and volunteers sign a copy of this document, individuals are making a collective statement that youth in the 4-H Youth Development Program are being treated with respect, dignity, and attention to individual needs. The faculty, educators, staff and volunteers who work with the 4-H Youth Development Program in Indiana are proud of the quality educational programs provided to youth of this state and to their personal commitment to nurture the positive growth and development of youth.

4-H Youth Development Program faculty, educator, staff, and volunteers agree to the following:

- Respect, adhere to, and enforce the rules, policies, and guidelines established by the Purdue Extension Service including all laws related to child abuse and substance abuse.
- Accept supervision and support from salaried Extension staff or designated management volunteers.
- Be mindful and follow Purdue, Centers for Disease Control and Prevention (CDC), and other state and local health authority guidelines and recommendations related to any epidemic or pandemic illness.
- Participate in orientation and training, which includes youth protection standards, sponsored by the Purdue Extension Service.
- Accept my responsibility to represent 4-H Youth Development Programs with dignity and pride by being a positive role model for youth.
- Conduct myself in a courteous, respectful manner, exhibit good sportsmanship, and demonstrate reasonable conflict management skills.
- Be truthful and forthright when representing the 4-H Youth Development Program.
- Recognize that verbal or physical abuse, failure to comply with equal opportunity and anti-discrimination laws, or committing criminal acts are not acceptable practices in 4-H Youth Development Programs.

- Embrace diversity among all youth and adult participants, helping each person to feel welcome and included in the 4-H Youth Development Program.
- Under no circumstances allow, consume, or be under the influence of alcohol or illegal drugs at 4-H Youth Development Program events or activities.
- Operate machinery, vehicles, and other equipment in a safe and responsible manner when working with youth participating in 4-H Youth Development Programs.
- Treat animals in a humane manner and teach program participants appropriate animal care and management.
- Use technology and social media in an appropriate manner that reflects the best practices in youth development. During virtual 4-H activities, I will follow acceptable University practices being mindful of the virtual learning environment.
- Accept my responsibility to promote and support the 4-H Youth Development Program in order to develop an effective county, state, and national program.
- Report any suspected instances of child abuse and/or neglect to local authorities that I may observe during my role as a 4-H Youth Development Program faculty, educator, staff, or volunteer.

Using the 4-H Name and Emblem

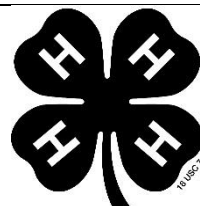

Coordinators should work with their County 4-H Youth Extension Educator to assure proper usage of the federally-protected 4-H Name and Emblem.

Youth Resources

Exhibit Guidelines

Note: County guidelines take precedence. However, any projects chosen for the Indiana State Fair must follow State Fair guidelines. Shooting Sports project information is available from the Indiana 4-H website: purdue.ag/4hshooting sports.

Indiana State Fair Shooting Sports Education Exhibit Guidelines

Create an exhibit that shows the public what you learned in Shooting Sports education this year. Exhibits must be displayed horizontally, sized 22" x 28", mounted on a firm backing (foam-core board or other), and covered in clear plastic or other transparent material. Be sure to include a label with your name, grade, and county. Title your exhibit with one of the following: archery, outdoor skills, muzzleloading, pistol, rifle, shotgun, or Shooting Sports. You can use a subtitle, if you wish.

Important Notes:

- Firearms or ready to shoot bows are not allowed to be exhibited. Unstrung bows are permissible.
- Live ammunition is not allowed to be exhibited (no powder or primer).
- An arrow with its arrowhead attached must be displayed in a secure case. An arrowhead without the arrow attached should be displayed in a secure case. An arrow may be displayed unsecured if its arrowhead is removed. Modern broadhead arrows are not allowed to be exhibited.
- Displays of firearms or bows may be exhibited as a photographic display on a poster or in a notebook following grade level guidelines.
- Handmade items must include information explaining how the project was made and its intended use. Photos are encouraged.

Grade: 3rd through 5th (one State Fair entry per county)

Display a poster showing what you learned in the 4-H Shooting Sports project.

Grade: 6th through 8th (one State Fair entry per county)

Choose one of the following options. Exhibits **MUST** meet the size restrictions or be presented in a notebook.

1. Poster
2. Small project or model no larger than 18 x 18 x 36 inches.
3. Notebook, showing how a Shooting Sports item was made, or project completed.

Grade: 9th - 12th (one State Fair entry per county)

Choose one of the following options.

1. Poster
2. Project or model (may be any size) and explanation of costs and procedures.
3. Notebook, showing how a Shooting Sports item was made, or project completed.

Independent Study: Grades 9-12, one State Fair entry

- Advanced topic - Learn all you can about an advanced shooting sports topic and present it on a poster. Include a short manuscript, pictures, graphs, and list the works cited to describe what you did and what you learned. Title your poster, "Advanced Shooting Sports – Independent Study."
- Mentoring - exhibit a poster that shows how you mentored a younger 4-H member. Include your planning, the time you spent, the challenges and advantages of mentoring, and how the experience might be useful in your life. Photographs and other documentation are encouraged. Title your poster, "Advanced Shooting Sports – Mentor."

Judging Score Sheet

Indiana State Fair 4-H Shooting Sports Judging Score Sheet

Note: age appropriate judging is critical so that each youth is treated fairly. Young 4-H members (grades 3 – 5) should not be expected to have the fine motor coordination or advanced thinking skills of an older 4-H member. Originality is expected of high school youth.

All poster exhibits are 22" x 28" and displayed horizontally. The poster must be on foam-core board or backed to stand-alone and include a title and label.

Circle One: Grade 3-4 Grade 5-6 Grade 7-9 Grade 10 & above

Circle One: Poster Notebook Educational Display Project (list item): _____

	Poster/ Notebook	Hand-made item	Excellent	Good	Needs Improv.
Content and Information (accuracy & completeness)	40%	15%			
Originality and Creativeness (attracts interest, encourages thought)	20%	10%			
Useful to Discipline	10%	10%			
Knowledge of the Discipline	10%	5%			
Suitable Subject and Age Appropriate (matches grade and ability)	5%	10%			
Conveys Message/Accomplishes Purpose	5%	5%			
Quality of Workmanship	5%	40%			
Meets Exhibit Requirements	5%	5%			

Judge's Comments:

Indiana 4-H Shooting Sports Manual

The Indiana 4-H Youth manual is recommended for introductory use. It includes information and activity suggestions for the disciplines that we offer in Indiana. These manuals may be ordered from Purdue's The Education Store, www.edustore.purdue.edu (Order # 4-H 950). A package of 10 manuals sells for \$25.00 (2020). Topics covered include:

- Safety
- Eye dominance
- Discipline activities
- Resources
- Record Sheets
- Glossary

Older youth and those who want to pursue a discipline in more detail are recommended to use the NRA manuals listed in the Publications sections.

Answers to the IDs, word finds, crossword puzzle, and additional information about youth development stages, experiential learning, and making a good poster, are in the Leader's Guide, available from The Education Store, www.edustore.purdue.edu, enter 4-H-1007-W in the search box (free download).

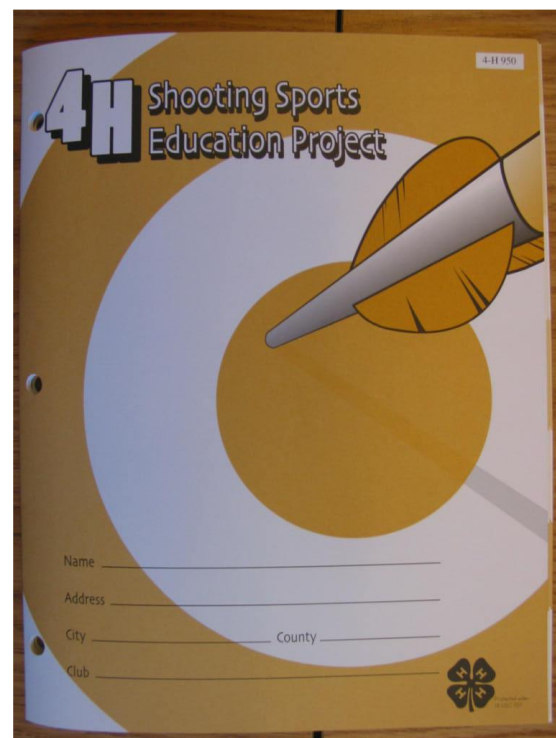

Example page, Muzzleloading

Muzzleloading

Name the locks. Label the parts of the muzzleloader using the letters listed with the appropriate word at the bottom of the page. Then find the words in the word search.

A - BARREL
B - BUTT PLATE
C - CAP LOCK
D - FLINT LOCK
E - FRONT SIGHT
F - HAMMER
G - INLINE LOCK
H - MATCH LOCK
I - MUZZLE
J - RAMROD
K - REAR SIGHT
L - SET TRIGGER
M - STOCK
N - TRIGGER GUARD
O - WHEEL LOCK

10

Work with your Shooting Sports Instructor to determine the project that is right for you. Your instructor will consider your interests, age, experience, and abilities to help you choose a project that is right for you.

Project Ideas

- Show the parts of a muzzleloader, including diagrams of different ignition systems.
- Show the differences between shooting muzzleloading firearms and cartridge firearms of the same type.
- Make a timeline of the history of muzzleloading firearms or black powder.
- Study a re-enactment local event or living history.
- Make a poster to present safe handling and storage of percussion caps and black powder.
- Show the proper loading sequence for muzzleloading rifles.
- Demonstrate proper cleaning procedures for a muzzleloading rifle to an appropriate audience.
- Show or demonstrate muzzleloading range safety.
- Make a loading stand.
- Make and display a powder bag.
- Make a powder measure.
- Make a powder horn.
- Make a set of cross sticks.
- Build a shooting bench.
- Build a rifle or pistol with a clear barrel to show the correct load.
- Refinish a gun stock.
- Learn to brown or blue a barrel.
- Make a gun rest.
- Make a kneeling roll.
- Describe how to clean and store a muzzleloader.

Games & Activities

Shooting games and activities can be fun. Ask your instructor for ideas. Older youth can help you do them. Older youth can help you do them. Older youth can help you do them. Older youth can help you do them.

- Participate in a muzzleloading re-enactment.
- Split a ball on a double break two clay targets.
- Split a playing card in half.
- Stick a tomahawk.
- Start a fire with flint and steel.
- Cut the string holding the string.

Meeting Log

Date: _____

Explain what you did and what you learned. Use the back of this sheet for additional information or sketches.

Sketches, pictures, etc.

Poster Exhibit Guidelines and Suggestions

(By Roger Sherer, retired Extension Educator, Wells County)

Display a poster relating to something you learned from your project manual.
 You must choose a new topic each year.
 Choose a creative title for your poster that gives viewers an idea of your topic.
 Include a name label in the lower right hand corner.

Suggestions:

Poster board – use white when required and experiment with other colors when not required. All posters must be 22” x 28” unless otherwise specified.

Mounting adhesives – the best is rubber cement (it leaves no marks and won’t wrinkle paper).

White glue should be used only in cases where wrinkling or damage will not occur.

Colored pencils – the best are soft leaded – they are easy to color and blend easily – strokes will not show if handled properly – hard leaded pencils are less expensive but are more difficult to use. (Soft leaded pencils can be purchased at art stores.)

Labels – Plain 3” x 5” file cards (cut to the proper size) work exceptionally well – they have a smooth finish, are sturdy enough for gluing and removing smudges.

Stiff backing – any material that will keep the poster from bending forward will work. Foam core board is a popular choice, if you can get it in the proper size. Some examples are: very stiff cardboard, plywood (this can make the poster very heavy); and masonite (1/8” thick works well and could be used year after year).

Acetate or other clear plastic covering – this is required for most posters to keep them clean before judging and keep fairgoers from touching them. Coverings generally come in various thickness (3, 5, 7 ½, and 10 mil) in rolls or sheets.

Plastic tape – this is not necessary but it makes attaching poster board to the stiff backing easy.

Tape is available in many colors, cloth or plastic, and widths. The 1 ½” wide tape can give the poster a border. Available at discount stores.

Lettering – Stencils, self-adhesive or press-type letters may be purchased at discount or art stores. Some youth prefer to type their labels and title on a computer.

County ID labels – an identification label should be placed at the lower right hand corner of poster projects. Labels are available from your leader or at the County Extension Office. The label should include township, article, project, year, and your name.

Your poster should read like a dollar bill.

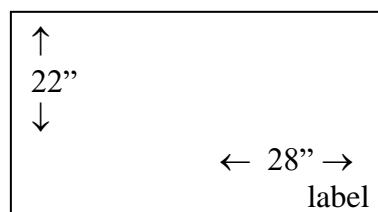

Poster Exhibit Guidelines

(By Amy Nierman, former County 4-H Extension Educator, and Angela Apple)

<p>Good Poster</p> <ul style="list-style-type: none"> • Attracts attention • Is simple and clear • Sparks an interest in Shooting Sports <p>When forming ideas for your poster</p> <ul style="list-style-type: none"> • Know the project requirements • Read the manual – look for ideas • Brainstorm ideas and make a list • Think of titles with alliteration (repeating a sound in words) • Look at other posters for ideas – but <u>don't copy</u> <p>Steps to follow when making a poster:</p> <ol style="list-style-type: none"> 1. Read your project manual 2. Read your county project requirements 3. Decide on information to include on the poster 4. Sketch out your idea 5. Collect supplies 6. Mark guidelines for lettering and pictures (lightly) 7. Layout letters, pictures, etc. on the poster. 8. Cement (glue, etc.) 9. Clean up the poster so it is neat. Erase any guidelines that are showing. Remove excess rubber cement or glue. 10. Glue poster to backing 11. Cover poster with plastic 12. Take your poster to the fair on the right day and time 	<p>Tips to remember</p> <ul style="list-style-type: none"> • Don't use too many words • Use a combination of illustrations and words • Be as neat as you can • Cut evenly, cement carefully, blend colors when using crayons or colored pencils • Leave white space on the poster • Make sure the poster is balanced • Choose colors carefully. Note the following general guidelines: <ul style="list-style-type: none"> – Black tends to be more formal, neat, rich, strong – Blue is cool, melancholy, or depressed – Purple is considered royal, rich, imperial – Red stands for love as well as anger and hatred – Orange is generally used for Halloween and is festive – Yellow tends to be warm, light, or ripe – Green is fresh, young, or growing – White means pure, clean, and neat <p>Things you should never do</p> <ul style="list-style-type: none"> • Make a vertical poster • Use Saran Wrap to cover • Use staples, tacks, or tape • Use fluorescent posters • Create a poster that is all words or a poster that is all pictures
--	---

Record Sheets

Some record sheet examples follow. You are welcome to copy them and use them as they are or to create your own. If youth keep their Shooting Sports record sheets, meeting times, and other forms in a folder or notebook, they are less likely to be lost.

Please Note: The forms and suggestions provided in this manual are for reference only. Each Shooting Sports instructor team should determine what to use in their county program based on local resources and needs.

The Value of Record Sheets

- Keeping record sheets help youth learn responsibility.
- Recording what was done helps youth to remember what they learned in a class.
- Record sheets are valuable references for youth when applying for 4-H (and other) scholarships. Without good records, the information can be very difficult to compile.

Personal Goals Record Sheet

(Complete at the beginning of the project year.)

What I would like to learn in this project:

What I would like to do in this project

(with the club or making something related to shooting or wildlife):

Other goals, objectives, questions, etc.

Summary Record Sheet

(3/03)

(Complete at the end of the project year.)

Name _____ Grade _____ Year 20_____

Name of Club _____ Year in club work _____

County _____ Township _____

What I experienced in this project

What did you do this year in the 4-H Shooting Sports program?

(Summary of what firearms, archery, or other equipment you used, what exhibit you completed, field trips that you took, etc.):

What I learned in the 4-H Shooting Sports program

Explain what you learned. (Some examples are: shooting skills, information gained about wildlife and other natural resources, safety concepts that you learned, and learning to work with others.)

Describe how the 4-H Shooting Sports program has helped you:

How can you use what you learned in the 4-H Shooting Sports program in other 4-H projects, at home or at school?

I have reviewed this record and made comment about the individual's progress and completion.

Signature of Facilitator/Leader _____ Date _____

Youth Educator Responsibilities

4-H Youth Development Extension Educator Responsibilities

The county 4-H Youth Development Extension Educator, as the paid Purdue staff member, is responsible for the overall guidance and coordination of the county 4-H Shooting Sports program. The educator works in conjunction with the State 4-H Office. They are responsible for all volunteer screening, references, approval, placement, removal, and other paperwork pertaining to the management of volunteers. They are also required to submit a compliance statement and range plans to the State 4-H Office for the Shooting Sports program. Requests for a Certificate of Insurance must originate with the educator. The 4-H Youth Extension Educator is generally the person responsible for sending in the paperwork for potential Shooting Sports volunteers wishing to attend a certification workshop. If the coordinator sends in the registration form for the certification workshop, they need to be sure that the 4-H Youth Extension Educator is aware of it and that the volunteer has been screened and accepted into the county program.

Documentation

The 4-H Youth Development Extension Educator has the primary responsibility for the 4-H Shooting Sports program. They have many and varied responsibilities and are required to manage multiple programs and work with many volunteers. They must make sure that office personnel and volunteers maintain the appropriate use of the 4-H Name and Emblem and that all guidelines for using the emblem are followed. There are also a number of forms and requirements specific to 4-H and the 4-H Shooting Sports program that must be maintained. The County 4-H Youth Educator should have the following:

- Shooting Sports Compliance Statement: Educator assurance that policies and procedures are being followed.
- 4-H Shooting Sports Range Plan, plans for each range that is used for the 4-H Shooting Sports program.
- Copy of any Requests for Certificate of Insurance (RM02). If requested by property or equipment owners, this form is used to obtain a copy of Purdue's liability insurance coverage extended to property and equipment used in the 4-H Shooting Sports program. The certificate is valid for one calendar year.
- List of Certified 4-H Shooting Sports instructors.
- 4-H Shooting Sports equipment inventory.
- 4-H Volunteer Application (4-H 784), required of all volunteers before they are offered a position as a 4-H volunteer.
- Adult Behavioral Expectations (4-H 785), all volunteers must agree annually to the stated behavioral expectations.

Insurance Coverage

Liability Insurance

- Purdue provides liability coverage for bodily injury or personal injury to third parties
 - Includes damage to their property when such injury is the result of Purdue’s negligent act
- Personal injury includes:
 - Defamation of character
 - Invasion of privacy
 - False arrest
- Do not confuse liability with medical coverage (medical coverage is not provided by Purdue)
- The University, its employees, and its volunteers are covered by this policy
- Coverage includes: Payment of claims or legal settlements and defense costs
- If an accident or injury occurs, **IMMEDIATELY contact extension staff**

Talk with your county 4-H Youth Extension Educator if you have questions about insurance coverage.

Auto Liability

- Your personal insurance coverage is always primary. (Recommended minimum limit for personal insurance is \$100,000 per accident for bodily injury and property damage.)
- Purdue provides coverage for bodily injury to third parties and damage to their property when an injury is the result of the operation of an employee’s or volunteer’s personal vehicle when on official university business.
- The University, its employees, and its volunteers are covered.
- School bus coverage is not provided by Purdue University.
- Additional guidelines apply to transport a group of youth to an event. Talk to your 4-H Youth Extension Educator.

Accident and Illness Coverage

- Accident and illness coverage policies are purchased through American Income Life Insurance Company by the State 4-H Office for 4-H events and activities to cover all 4-H members and approved 4-H Volunteers.
- Special Activities Policies may be purchased for certain events. Talk with the County 4-H Youth Extension Educator for more information.

Equipment Coverage

- Insurance to cover the loss of or damage to 4-H Shooting Sports equipment is the responsibility of the local 4-H Shooting Sports program. Purdue University does NOT provide this coverage.

Final Notes

- Purdue coverage is broad, but not everything can be covered.
- Indemnification resolution: Coverage is in place as long as person is:
 - Acting in good faith.
 - Acting within scope of his/her duties.

- Supervision of youth - ratio of adults to youth:
 - Have at least two approved 4-H Volunteers on site before the first youth arrives and after the last youth leaves.
 - Mixed groups require both male and female chaperones.
 - Discourage an individual adult from being alone in a room (or car) with a child.
 - Provide more than one adult with a group, in case of an emergency.
 - Consider the type of activity, number of participants, age of participants.
 - A common sense approach is best and MORE IS BETTER!

Starting a 4-H Shooting Sports Program

Steps in getting the program started

Starting and maintaining a 4-H Shooting Sports program is most successful when the county 4-H Youth Extension Educator and the certified 4-H Shooting Sports coordinator work closely together. The following steps are recommended.

- 1) Call a meeting of adults that might be interested in helping with the program. If you are restarting a program that has languished (or been inactive), invite any previously active certified instructors. The 4-H Youth Educator can obtain this list from the State 4-H Office.
 - a) Invite youth interested in the program to get their input.
 - b) Discuss the general objectives for the program and what you and other meeting attendees hope to achieve by offering this program in your county.
 - c) Explain the requirements for adult volunteers in this program. All 4-H volunteers must apply and be accepted as a county volunteer 4-H instructor. This process documents volunteer excellence and includes:
 - A written application (4-H 784) including three references.
 - A reference check (written, via e-mail, or by phone) by the Extension Educator.
 - Clearance through the National and Indiana Sex and Violent Offender Registries, by the 4-H Youth Extension Educator.
 - A recommendation or denial of the applicant's involvement by the 4-H Youth Extension Educator.
 - All volunteers are annually required to sign the Adult Behavioral Expectations Form (4-H 785). This form allows everyone to reaffirm their commitment and dedication to the well-being of youth.
- 2) Volunteers must attend (and successfully complete) a 4-H Shooting Sports certification training workshop. Certified instructors are required for each discipline that your county will be offering. At least one certified 4-H Shooting Sports coordinator is required for each county.
- 3) Other adults can help with the program, but if they want to take responsibility for teaching a discipline, they would need to attend certification training and complete the usual volunteer screening process.
- 4) Decide what disciplines your county will offer youth. This decision depends on many factors, including the interests and expertise of the adults, the availability of ranges, financial resources, and the interests of the youth. It is often best to start with just a couple of disciplines. The most common are archery and rifle (using air rifles). The Outdoor Skills

discipline can be used for introducing younger members (3rd grade) and then start rifle and archery with 4th grade and up. Counties may choose to offer the shotgun and muzzleloading disciplines only to older kids because of the size and cost of these firearms. Find volunteers to lead each discipline you will offer and send them and your coordinator for certification training.

- 5) Find ranges for each discipline your county will offer. The 4-H Youth Extension Educator must submit the required range plan forms to the State 4-H Office. No shooting is allowed until the 4-H Youth Extension Educator has received word that the range has been accepted.
- 6) Costs vary widely with the discipline and whether your county purchases equipment or allows the 4-H members to use their own equipment. Ammunition can be costly, so most programs charge members between \$5 and \$50, depending on the discipline.
- 7) Work with your County 4-H Youth Extension Educator and perhaps a local 4-H Council to determine the best method to insure any equipment that is owned by the 4-H Shooting Sports Program. No insurance coverage is provided by Purdue University for the 4-H Shooting Sports equipment.
- 8) Visit programs in your area. Most counties in Indiana have a 4-H Shooting Sports program. You can learn a lot by visiting with and talking to coordinators and discipline instructors in surrounding counties.
- 9) Invite experienced Shooting Sports instructors and/or coordinators from surrounding counties to a meeting. They can give you a lot of valuable insight about what works well, challenges that they have had, etc. The County 4-H Youth Extension Educator can help you find these people by asking their colleagues for suggestions of outstanding programs.

Glossary of Shooting Terms

ACP - abbreviation for Automatic Colt Pistol, for example .45 ACP

Action - the parts of the firearm that load, fire, and eject the cartridge

Action release - a device that unlocks the action; normally found on semi-automatic or slide-action firearms; also called a bolt release in some cases

Adapter - 1) a fixture on the bow for attaching an accessory like a bow quiver, stabilizer, cable guard, bow-fishing reel or sight; 2) part of the arrow that permits attachment of a nock or point (see screw-in adapter)

Adjustable arrow plate - arrow plate that can be adjusted to achieve better arrow flight, usually using set screws or micrometer adjustments

Aim-point - an optical sight that superimposes a spot of light on the image of the target

Air charge - the compressed air used to propel the pellet in a pneumatic pellet gun

Alignment - 1) relationship among two or more items; 2) having all elements true, square and in line with each other

Ambidextrous - able to use both hands with equal dexterity

Ammo - shooter's jargon for ammunition

AMO - Archery Manufacturer's Organization, a trade association of all archery equipment manufacturers

Anchor - 1) holding the string at full draw; 2) position of the string, fingers, hand, or mechanical release at full draw (see also high anchor and low anchor)

Anchor point - a stable reference point for anchoring the string at full draw

Antimony - metal often alloyed with lead to produce a harder shot or bullet material

Apache draw - extremely high anchor point, anchoring the nocking point on the cheekbone directly under the dominant eye, preferred for short-range shooting by some archers

Aperture - a hole or opening in a sighting device, like the hole in the center of a receiver or peep sight disk

Aperture rear sight - 1) device anchored in the string at eye height that the archer looks through at the sight pin; aids in precise sight alignment; commonly used in some archery shooting games, illegal in others; also called a string peep or peep sight; 2) metallic rear sight for a rifle, pistol, or shotgun in which the shooter looks through an aperture centering the front sight or front aperture in the opening and aligning the sights with the target; also called a receiver sight or peep sight

Apothecary measure - measurement standards used in pharmaceutical and pharmacy measurement

Archer's paradox - observation that an arrow must flex to fly true to a mark

Arm guard - protective device worn on the inside of the bow arm to keep the clothing out of the string's path and to protect the arm from abrasion by the string

Arm-rest standing position - the standing rifle shooting position where the upper arm is rested against the side of the body for support and stability

Arrow plate - lateral rest for the arrow; pad or part of the arrow rest holding the arrow away from the side of the riser

ATA - Amateur Trapshooters Association, the governing body for American trap shooting in the United States

Arrow rest - a device for supporting an arrow while it is at rest or being drawn

Arrow shelf - the flattened area at the bottom of the sight window on bows with a center shot cutout

- Attitude** - the orientation of the body relative to the target
- Back** - those parts of the bow pointing down range when the bow is properly held in shooting position
- Back quiver** - an arrow-holding device designed to be worn on the archer's back, either centered (center-back quiver) or over the shoulder
- Backer** (backing target) - a second target used to verify shots fired into the record target from other firing points
- Backstop** - the ultimate stopping point for a projectile, often an earthen barrier, berm, or slope
- Ball puller** - a screw device used to retrieve a ball from a muzzleloader
- Ball starter** - a device used to insert the ball into the muzzle (short starter) or push it a short distance down the bore (long starter)
- Bare bow** - shooting without the aid of sights or other accessories to aid in sighting; purely "instinctive" shooting
- Barrel** - the tube that contains and directs the projectile [see also bore, chamber, rifling, muzzle]
- Barrel lug** - an extension of the barrel or attachment to the barrel used to attach it to the stock
- Barrel wedge** - tapered pin used to anchor the barrel to the stock on muzzleloading firearms
- Base wad** - the wad surrounding the battery cup in a shotshell; may be composed of fiber, rolled paper, plastic, or formed from the hull material
- BBs** - 1) steel projectiles for air guns, approximately .177 caliber; 2) standard shotgun shot size, approximately .18 inch in diameter
- Bead** - 1) the pointing or sighting aid(s) on a shotgun barrel; may be a small metal bead on a threaded post, a plastic or glass cylinder or a similar object; mid-rib beads are smaller; 2) the primary sighting area of a bead-and-post rifle sight
- Beavertail forend** - broad shotgun forend commonly seen on doubles, with a shape similar to a beaver's tail
- Bedded barrel** - a rifle barrel completely and consistently in contact with the stock material for the entire length of the fore stock
- Bench-rest position** - a rifle shooting position where the shooter is seated at a bench and the rifle is supported on a rest, cradle or sandbags; often used for sighting-in purposes
- Blooper** - an under-powered shotshell that fires with an unusually loud, flat-sounding report; shot and wad may or may not exit the barrel; complete safety check should be made before another shot is fired
- Blunderbuss** - matchlock firearm featuring a bell-shaped muzzle, commonly associated with the Pilgrims
- Blunt** - a flat or broadened arrow point designed for hunting and killing small game
- Bolt** - 1) moveable locking device that seals a cartridge in the chamber of a firearm, usually contains the firing pin and a means of extracting cartridges from the chamber; 2) a quarrel or arrow for a crossbow; 3) a threaded rod used as a connector
- Bolt action** - firearm action designed around a manually operated bolt; both turnbolt and straight-pull designs in use
- Boone and Crockett Club** - one of the major organizations maintaining records of North American big game animal trophies
- Bore** - channel through which the projectile(s) travel while in the barrel
- Bore size** - 1) the diameter of the bore in a rifle, measured in caliber (hundredths or thousandths of an inch) or millimeters (mm); 2) the gauge or caliber of a shotgun
- Bore swab** - cleaning fixture made of fiber or fabric used to apply solvent, remove fouling, dry the bore or apply oil to the bore

- Bow case** - a protective device for the bow; may be either hard (with high impact resistance) or soft (designed to prevent damage by scraping or minor bumps)
- Bow hand** - hand holding the bow when in proper shooting position; the hand associated with the non-dominant, non-shooting or “off” eye
- Bow-hand side** - the side of the body or target associated with the bow hand
- Bow press** - a device to compress the limbs of a bow, usually used in servicing compound bows or checking adjustments in draw weight
- Bow quiver** - an arrow-holding device designed to be attached to the bow; safety demands that the arrowheads be covered by a cowl or shield on all bow quivers
- Bow scale** - a scale used to find the draw weight, peak weight or holding weight of a bow
- Bow stringer** - a device used to string or unstring a conventional bow (recurve or longbow)
- Bowyer** - a designer and builder of bows
- Breech block** - solid block of metal, either moveable or fixed in position that seals or locks a cartridge in the chamber of a rifle or shotgun
- Breech plug** - threaded plug that seals the breech end of a muzzleloader barrel
- Bridle** - plate that holds internal working parts of the lock in place
- Broadhead** - an arrowhead designed for hunting large game animals and to kill by hemorrhage
- Buck shot** - cold-swaged or cast lead pellets designed to be fired in a shotgun, ranging in size from No. 4 (approximately .24 caliber) to 000 (approximately .375 to .380 caliber)
- Buckhorn sight** - open rear sight with high, curved sides
- Bull** - 1) abbreviated term for bullseye or center portion of a target; 2) term applied to adult male elk, moose or domestic bovines; 3) content of discussions when shooters or hunters gather to talk
- Bullet board** - loading block holding pre-lubed or patched and lubed bullets or balls, used as a means of speeding loading in a muzzleloading rifle or pistol
- Bullet mass** - weight of a bullet divided by the acceleration of gravity, generally measured in slugs (pounds/32 feet per second squared) although bullet weight is measured in ounces (shotgun slugs) or grains (rifle bullets or balls); must be calculated to determine bullet energy
- Bullet point** - target or field points that curve to a point like a spitzer bullet (have a radius curve or ogive)
- Bullseye** - center portion of a circular target; aiming dot on a target
- Butt** - 1) target backing device designed to stop and hold arrows without damage, may be made of foam blocks or baled materials like paper, straw, excelsior, sugar cane fiber, marsh grass or plastic foam; 2) shoulder end of a rifle or shotgun stock; 3) a shooting stand or blind
- Bull plate** - protective device attached to the shoulder end of the butt stock usually of metal, horn, plastic or rubber
- Cable** - wire ropes used to provide mechanical advantage on compounds bows and cammed limb bows
- Cable guard** - device designed to hold the cables away from the path taken by the arrow when it is drawn or shot
- Caliber** - diameter of a firearm bore measured in hundredths or thousandths of an inch or in millimeters
- Cam** - 1) an eccentric wheel with changing radius around its perimeter; 2) eccentric wheel designed to prolong the peak draw weight of the compound bow, altering its draw force curve to increase its efficiency
- Cam bow** - two-wheel compound bow featuring cams rather than round eccentric wheels
- Cammed limb** - limb design with cam action at the bases of the limbs rather than at their tips

- Cammed limb bow** - bow design featuring cammed limbs
- Cant** - holding the bow or firearm at a slight angle to the perpendicular
- Cap-and-ball** - a revolver type intermediate between muzzleloading pistols and cartridge pistols where the cylinder consists of several short muzzleloading chambers with a cap at the rear
- Caplock** - 1) lock designed for use with percussion caps; 2) a rifle or shotgun using a percussion lock
- Capper** - a device used to hold percussion caps and press them into place on the nipple of a muzzleloader
- Cardinal rules of safety** - three fundamental rules of firearm and archery safety including 1) empty and open until ready to fire, 2) muzzle or arrow pointed in a safe direction, and 3) fingers off the string or trigger until ready to fire
- Cartridge arm** - any firearm using fixed ammunition
- Center-of-mass hold** - holding the aligned sights on the center of the bull or target, with the firearm or bow sighted to place the projectile at the top or center of the front sight
- Center-fire** - a firearm using a primer or battery cup located in the center of the cartridge head
- Chamber** - rear portion of the firearm barrel, shaped to hold and support a specific cartridge
- Chambering** - v. milling or cutting the breech end of the barrel to the dimensions specified for the appropriate cartridge; n. 1) the process of cutting the chamber in a firearm; 2) the dimensions of the chamber on a firearm or the cartridge for which it was cut
- Change roles** - coach and pupil exchanging responsibilities during coach-pupil instruction
- Channel** - opening or tube
- Chilled shot** - fine shot made with a hard lead alloy containing antimony or tin and antimony
- Checkpoint** - any reference point used by the shooter to be sure the anchor point is properly located
- Checkering** - n. 1) textured surfaces on the firearm stock, frame or hammer designed to increase the security of the shooter's grip; 2) individual diamonds or other patterns within the textured surface; v. cutting or pressing the textured surface on a firearm
- Choke** - 1) a device or barrel structure designed to control the pattern of a shot, generally available in cylinder, skeet (or skeet 1), improved cylinder, quarter choke, skeet 2, modified or half choke, improved modified, full and extra full; 2) the amount of choke present in a particular barrel; 3) losing concentration under pressure
- Choke tube** - fixed or changeable sleeve containing a choke device
- Cleaning jag** - fitted device attached to a cleaning rod designed to hold a cleaning patch securely and tightly in the barrel
- Clicker** - spring-loaded device attached to the riser near the arrow rest to signal when the arrow has been drawn fully, often used by target shooters who suffer from target panic or freezing as a release signal
- Climbing block** - a portable device used in climbing trees without penetrating the bark
- Clip** - a removable box magazine for rifle, pistol or shotgun cartridges
- Clout** - long-range target game featuring a large horizontal target in concentric circles around a central flag
- cm** - abbreviation for centimeter, 1/100 of a meter or approximately 0.4 inch
- Coach/pupil method** - teaching technique where two shooters support and reinforce learning, switching roles after each portion of the shooting session
- Cock** - "hammer" of a flintlock action
- Collet choke** - variable choke device where the amount of choke constriction is controlled by turning a collet that controls the attitude of a set of steel fingers within the device

- Comb** - upper edge of the butt stock, the part in contact with the cheek or face
- Components** - elements or pieces that make up a whole, in handloading it refers to the powder, primers and other items needed to create a new cartridge
- Composite** - made up of several materials (fiberglass and graphite limbs, for example, are composites of those fibers in a plastic matrix)
- Composite limb** - limb made of composite materials
- Compound bow** - bow designed to give the shooter a mechanical advantage during the draw, changing the shape of the draw force curve and yielding a higher efficiency in energy transfer to the arrow
- Conical point** - target point with an abruptly conical shape, tend to deflect more than bullet points when striking other arrows
- Constriction** - difference between bore diameter and choke diameter in a shotgun
- Controlled access** - restricting access to authorized and responsible persons
- Crimp** - 1) folded seal on a shotshell or blank rifle or pistol cartridge; 2) slightly rolled or indented area at the neck of a rifle or pistol cartridge designed to hold the bullet in place
- Creep** - 1) tendency of the drawing hand to ease forward from the anchor point during or prior to release, usually caused by fatigue or excessive draw weight; 2) movement of the trigger without releasing the sear
- Crest** - lacquer indicia applied to the shaft between the fletching and the point and used to identify the arrow (see “signature”)
- Cresting lathe** - mechanical device used in applying crests or signatures to arrow
- Crooked stock** - butt stock with considerable drop at the comb and/or heel
- Cross hair** - reticle consisting of a pair of hairs, wires or similar structures arrayed at right angles and centered in the sight
- Cup grease** - heavy grease used to seal the mouths of the chambers in a cap-and-ball revolver
- Cushion plunger** - adjustable and spring-loaded lateral arrow rest or side plate
- Cylinder pin** - pin or post that supports the cylinder of a revolver
- Dead release** - release without increasing tension in the back and shoulder muscles, in extreme cases while the drawing hand is creeping forward
- Deformation** - alteration of the shape of bullets or shot, particularly due to acceleration, contact with the barrel or impact
- Degrees of choke** - amount of constriction or choke in a shotgun barrel
- Desiccant** - a drying agent
- Dock spike** - a long, heavy nail used in construction of piers, docks and similar structures; useful as tent pegs and anchoring pegs for equipment
- Dot** - reticle consisting of a small dot suspended on the intersection of nearly invisible cross hairs
- Double** - shorthand expression for double-barrel shotguns, usually refers to side-by-side doubles
- Dram** - unit of apothecary measure for volume, formerly used in measuring changes of black powder for shotshells
- Dram equivalent** - a velocity or pressure measure giving shotshell performance equivalent to a specified amount of black powder
- Draw** - 1) process of pulling the string back to the anchor point; 2) type of anchoring system used (such as Apache draw, high draw, low draw) cf. “anchor”
- Draw check** - device used to signal when the arrow has been drawn to a consistent length, often used by target shooters to combat target panic or freezing (see “clicker”)
- Draw check arrow** - marked arrow used to determine draw length or proper arrow length
- Draw force** - force applied to the string in drawing the bow to full draw

- Draw force curve** - draw force compared to the length the arrow is drawn, shape varies with bow design
- Draw length** - distance from the string to the arrow rest when an arrow is fully drawn to the anchor point
- Draw weight** - force required to draw an arrow to the anchor point
- Drift punch** - tapered metal tool used to direct the force of a hammer blow on a specific spot
- Drop** - 1) movement of the projectile toward the earth; 2) distance below the line of sight; 3) distance below an imaginary line extended along the rib or top of the barrel toward the butt stock
- Drop at comb** - drop measured at the front of the comb
- Drop at heel** - drop measured at the top of the heel
- Drop shot** - soft lead shot containing pure lead or very soft alloys formed by dropping molten lead through a calibrated screen in a shot tower (as most fine shot is made)
- Dry point** - pointing the shotgun at a target without firing or dry firing
- Duplex reticle** - reticle composed of tapered posts of heavy cross hairs with fine cross hairs in the center
- Eccentric** - wheel with the pivot point located off center so the effective radius changes as the wheel rotates
- Effective range** - distance at which a projectile remains capable of performing its intended task, determined in rifles or pistols by a combination of remaining energy and trajectory, determined in shotguns by a combination of pellet energy and pattern density
- Ejector** - device designed to automatically and completely remove a fired case from the chamber
- Empty mark** - a mark on the ramrod of a muzzleloader indicating the depth of the empty barrel
- End** - a series of shots fired before the arrows are scored or retrieved
- Energy** - the physical measure of potential to do work, computed as half the mass multiplied by the square of the velocity
- Escutcheon** - a metal plate insetted into the stock of a firearm, often used to reinforce a stress point on the stock
- Extra-full** - chokes giving pattern densities in excess of 85 percent of the shot charge in a 30 inch circle at 40 yards
- Extractor** - device designed to lift the cartridge from the chamber so the shooter can remove it manually
- Eyedness** - having a dominant eye, one that takes precedence in aligning a sight (like a fingertip) with an object when both eyes are open and unobstructed
- Fg** - coarsest granulation of black powder used in shoulder arms
- FFg** - granulation of black powder used in big bore shotguns and rifles
- FFFg** - finer grade of black powder used in small bore shotguns, pistols and rifles .45 caliber and smaller
- FFFFg** - finest black powder used in sporting arms, used only as priming powder for flintlock arms
- Face** - 1) the belly of the bow, the part that faces the shooter when the bow is in shooting position; 2) a target
- Felt recoil** - apparent recoil influenced by weight of the firearm, shooting position, stock design, action type and similar features
- Ferrule** - cylindrical or tapered tube designed for attachment of one object to another, for example attaching a broadhead to an arrow
- Ferrule cement** - a heat sensitive cement of low melting point used to attach ferrules to shafts

- Field point** - a heavy point with a more or less elongated tip of smaller diameter than the body of the point, often designed to match broadheads in mass or flight characteristics
- Fine shot** - shot produced by dropping molten metal through screens in a shot tower, commonly from approximately 0.18 inches in diameter (BB) to 0.08 inches in diameter (#9)
- Finger pinch** - tendency of the arrow to swing away from the rest during the draw, usually caused by cupping or curling the hand and cured by keeping the back of the hand flat during the draw
- Fire control** - mechanical parts of the firearm that cause it to fire, including the trigger, sear, hammer, main spring and firing pin
- Firing point** - a designated shooting station or location
- Fish-tailing** - lateral oscillation of the shaft in flight, usually caused by improper spine, improper bow tuning, poor shooting hand form or misaligned nocks
- FITA** - Federation Internationale de Tir a l'Arc, the governing body for international, Olympic-style archery shooting using large, five color faces over known but relatively long ranges in open shooting fields
- Flange** - 1) a rim or lip on a cylinder, 2) rim or edge on a scoring gauge
- Flash hole** - channel from the priming pan of a flintlock to the breech and main powder charge
- Flash pan** - priming pan of a flintlock
- Fletch** - 1) to apply fletching to an arrow; 2) the type or style of fletching materials used
- Fletching** - feathers or vanes used to steer and stabilize the flight of an arrow
- Fletching cement** - cement used to apply fletching materials
- Fletching clamp** - clamp used to hold the fletching materials in shape and in place during application to the shaft
- Fletching jig** - tool used to hold the fletching clamp in proper alignment with the shaft while the fletching is being applied
- Fletching style** - number and placement of feathers or vanes, selected by considering trade-offs in speed, control, weather sensitivity, durability and noise in flight; common styles include vanes that are in line with the shaft (straight), angled across the shaft (angled), spiraled along the shaft (helical), or wrapped around the shaft (one type of flu-flu); usual numbers and placement involve three vanes at 120 degrees and the index vane perpendicular to the plane of the string and rest, four vanes at 90 degrees or 75 and 105 degrees, and six vanes at 60 degrees
- Flight** - 1) a group of shooters scheduled to shoot at the same time; 2) behavior of the arrow when it is actually in flight
- Flight line** - path taken by a flying target or game bird
- Flight shooting** - long range archery game where arrows are shot for maximum flight distance
- Flight arrow** - a specialized arrow with minimal fletching designed for flight shooting
- Flint** - extremely hard stone used in flintlock firearms and arrowheads
- Flintlock** - 1) lock used on flintlock firearms, featuring a cock, flint, frizzen and flash pan; 2) firearm using a flint-and-steel lock
- Flu-flu** - specialized arrow designed for limited flight distance and often used in shooting flying targets, game birds or small game; use spirally wound full-length feathers or six full-length feathers to slow arrow flight
- Fly** - connecting arm in the lock of a muzzleloader using double set triggers
- Follow through** - 1) continuing the appropriate action of the shooting sequence through the shot until the target is struck; 2) holding the bow and string hands or the firearm in their release or shooting positions until the arrow or bullet strikes the target; 3) continuing the swing on a

moving target until the target is struck

Forearm - front portion of a stock on firearms with a two-piece stock; forend or fore stock

Forend - portion of a stock between the action and the muzzle, also called a forearm or fore stock

Frend cap - metal or wood cap covering the extreme end of the forend

Fouling - powder residue or bits of metal left in the bore or other parts of the firearm as a result of shooting

Four position - rifle matches in which shooters fire stages from the prone, sitting, kneeling and standing positions

Four-wheel bow - compound bow design featuring eccentric wheels and idlers to aid in developing mechanical advantages, usually feature less let-off at full draw than two-wheel bows

Fowling piece - muzzleloading shotgun designed for bird hunting, usually double-barrel designs

Frangible - easily broken into pieces; frangible bullets come apart with explosive results

Free-floated barrel - rifle barrel that is firmly bedded at the receiver but does not touch the stock material for the length of the forend

Freezing - experiencing difficulty in releasing the string when the arrow is drawn and a sight "picture" is developed, also known as target panic; sometimes used for other shooting problems, like releasing as soon as the sight or other reference point touches the target

Frizzen - the hardened steel striking surface on a flintlock, produces sparks of burning steel when struck by the flint

Frizzen spring - spring that holds the frizzen in place prior to firing and helps it direct the spark into the flash pan

Full choke - choke device nominally delivering pattern densities of 70 to 80 percent in a 30 inch circle at 40 yards

Gas check - a gilding metal or other hard metal band at the base of a lead bullet; permits higher velocities and pressures than possible with a lead bullet

Gauge - standard shotgun borings, currently 10, 12, 16, 20, 28 gauges; formerly the number of bore diameter lead balls that could be cast from a pound of lead

Globe sight - an aperture front sight

Glove - protective device for the shooting hand usually with individual finger stalls for the three drawing fingers

Gold - bullseye or center of a five-color, FITA-style target

Grain - unit of measure for bullet weight; one grain equals 1/7000 pound

Granulation - a grade or size of individual black powder granules

Grip - v. to grasp or hold the firearm or bow in a manner that enables the shooter to control the arm; n. 1) the stock or handle of a handgun; 2) the area immediately behind the trigger guard on a rifle, musket or shotgun [see also straight or English grip, pistol grip]

Grooves - the spiral channels cut into the bore of a rifle or a shotgun choke

Ground quiver - device that is set on or stuck into the soil for holding the arrows upright with the tips on the ground or protected in a tube

Grounding - placing the bow on a rack or on the ground to indicate that the archer has finished shooting the arrows in that end

Group - cluster of arrows or bullets shot with the same form, aiming point, sight setting and other factors to determine the average point of impact for that combination

Half cock - a hammer position midway between the fired and fully cocked positions, often used as a safety device

- Hammer** - a spring-loaded striker that provides the force, directly or by transferring it to the firing pin, needed to detonate a primer, percussion cap, battery cup or priming compound in the rim of a cartridge
- Handedness** - dominance of a hand or side of the body, usually involves better dexterity for that hand
- Hang-fire** - delayed ignition of ammunition or a muzzleloading charge
- Handle** - grip portion of the bow
- Hauling line** - light line used by bowhunters to raise or lower equipment when using an elevated stand
- Head stamp** - identifying information on the head of a cartridge case
- Heel** - the upper portion of the butt or butt plate of a lung gun
- High anchor** - anchor point locating the nocking point near the corner of the mouth on the drawing hand side, often with a finger touching the canine or eye tooth
- High house** - the target house on the left side of a skeet field from which the target emerges 10 feet above ground level
- High house target** - targets thrown from the high house on a skeet field
- High velocity** - term to signify velocities above target load levels in shotgun ammunition or above some minimum velocity (approximately 2,500 feet per second) in center-fire rifles
- High wrist** - shooting style in which the bow-hand wrist is held in alignment with the forearm
- Hip quiver** - arrow holding device designed to be worn on the belt
- Hold** - 1) position of the aligned sights relative to the target or the intended point of impact; 2) relationship of the hands and archery equipment to the intended point of impact; 3) pause at full draw to check alignment, aiming point and form before release
- Hold over** - holding the sights, sight pin or other reference point above the intended point of impact to compensate for projectile being below the line of sight at the distance to the target
- Hold under** - holding the sights, sight pin or other reference point below the intended point of impact to compensate for the projectile being above the line of sight at the distance to the target
- Hooked breech** - barrel attachment style in muzzleloaders where an extension of the breech plug hooks into a steel base mounted in the rear of the barrel channel, permits easy removal of the barrel for cleaning
- Hydroscopic** - attracting moisture from the air
- Impact area** - the area in which the projectile(s) strike the backstop or ground
- Improved cylinder** - the most open or least constricted of the commonly used field chokes; nominally patterns about 45 to 50 percent of the shot charge in a 30-inch circle at 40 yards
- Improved modified** - choke often used in the bottom barrel of over/under trap guns; nominally patterns 65 to 70 percent of the shot charge in a 30-inch circle at 40 yards
- Indexing** - 1) aligning the cylinder of a revolver with the forcing cone on the barrel; 2) aligning the plug of a scoring gauge with the hole made by the bullet
- Inert** - deactivated, non-functional, incapable of action
- Inert ammunition** - dummy ammunition or ammunition loaded with deactivated or non-functional materials; action-proving ammunition
- International Bowhunters Education Program (IBEP)** This program is administered by the National Bowhunter Education Foundation (NBEF, www.nbef.org). Bowhunter Education prepares bowhunters to hunt ethically, competently, and safely.
- Idler** - wheel or pulley that changes the direction of a cable without altering the force applied
- Insert** - 1) fitted unit that fits into the hollow shaft of an arrow to permit attachment of either a

nock or a point; 2) blades fitted into a broadhead with replaceable blades; 3) small blades at right angles to the main blades on some broadheads (also known as “bleeder blades”); 4) elements in rifle sights that may be changed to suit the conditions or the shooter’s preferences

Instinctive shooting - shooting without the aid of sights or other aiming devices on the bow

Jacketed bullet - bullet composed of a lead core with a gilding metal or other harder metal bearing surface

Jag - a cleaning device designed to hold a patch on the cleaning rod in a specific sized bore

Jaws - top and bottom portions of a flintlock cock, designed to hold the padded flint securely

Jerking - moving the trigger or shooting fingers with a brief, violent motion

Judo head - specialized, spring-loaded head for roving or practice

Jumping a target - anticipating the flight line of a shotgun target and moving the shotgun in that direction before the target emerges

Kneeling - rifle shooting position; shooter sits on one foot or heel with the lower leg on the other side held vertically; the elbow of the forward hand rests on the knee providing support for the rifle

Lacquer - tough paint used in archery applications, often with an epoxy or vinyl base

Laminated - layers of material bonded together to take advantage of the characteristics of the component materials

Laminated limb - limbs composed of fiberglass or other composite materials on the surfaces with cores of wood

Lands - raised, spiral ridges left when rifling is cut in a barrel

Lanyard - cord attached to an implement to hold or operate it

Laser sight - sight that projects a laser dot onto the target

Laws of physics - fundamental relationships describing mass and movement of objects and the interactions of those factors

Lead fouling - deposits of lead left in the bore of a firearm

Length of pull - distance from the butt to the trigger

Limb - flexible portion of the bow from the riser to the tip

Line of flight - path taken by the arrow in flight

Line of sight - straight line from the eye, through the sight to the target

Live release - releasing the string while increasing the tension in the back and shoulder muscles (pulling the shooting elbow back), indicated by the shooting hand moving backward along the face or neck on the release

Loaded mark - mark on a muzzleloader ramrod to indicate the barrel is properly loaded

Loading port - opening through which a firearm may be loaded, usually serves as an ejection port as well

Loading ram - level activated rod on a cap-and-ball revolver that serves as a seating device for the ball

Lock - mechanical parts of a muzzleloader or other firearm

Lock plate - flat plate upon which the parts of a muzzleloader lock are assembled and held in place

Longbow - straight or slightly reflexed bow based upon the old English design; sometimes used in fish and game regulations to designate all bows with the exception of crossbows

Low anchor - anchor point locating the nocking point under the chin

Low-house - trap house on the right side of a skeet field (station 7) from which the target emerges 3 1/2 feet above ground level

- Low-house target** - targets thrown from the low house on a skeet field
- Low wrist** - shooting position in which the shooting firearm is relaxed, allowing the hand to be pushed upward by the pressure of the bow against the palm; position favored by target shooters
- Lubricated wad** - fiber or felt wad treated with a lubricant
- m** - abbreviation for meter, the base unit of length measure in metric units; approximately 10 percent longer than a yard
- Machining** - cutting or milling metal to specified dimensions
- Magazine** - 1) part of a firearm where ammunition is stored prior to being inserted into the chamber for firing; 2) a controlled storage area for ammunition or components
- Magnum shot** - very hard shot made with a lead alloy containing a high percentage of antimony
- Main spring** - the spring that is cocked to provide energy to the hammer or firing pin
- Malfunction** - failure of a firearm or ammunition to perform as designed; legally defined in the rules of shooting games
- Matching chokes** - process of selecting the appropriate choke for the intended use of a shotgun
- Matchlock** - 1) firing mechanism where a match is inserted into a touch hole to ignite the powder charge; 2) firearm using this type of lock
- Maxi ball** - flat-based muzzleloader bullet developed by Thompson Center Arms
- Micrometer** - measuring device using a graduated dial or set of dials to obtain precise measurements
- Micrometer sights** - aperture rear sights or externally adjusted telescopic sights with micrometer-style, graduated adjustment knobs that permit precise sight adjustment
- Milling** - machining process where metal is removed to form the appropriate part or dimensions
- Minnie ball** - conical bullet for muzzleloading arms developed in the mid-nineteenth century
- Misfire** - failure of a cartridge, percussion cap or powder charge to fire
- Mimetic** - mimicking or practicing a process without actually performing the act; practice steps without shooting
- mm** - abbreviation for millimeter, 1/1000 of a meter or approximately 0.04 inch
- Modified choke** - shotgun choke patterning approximately 55 to 65 percent of its shot charge in a 30-inch circle at 40 yards; also known as half choke
- Module** - integrated operating element of a firearm, like a trigger group or fire control mechanism
- Momentum** - physical measure of inertia, the mass multiplied by the velocity
- Musket** - smoothbore muzzleloading firearm suitable for use with either shot or ball
- Muzzle** - terminal end of the bore, opening from which the projectile or projectiles emerge
- Muzzle control** - maintaining adequate control of the firearm so the muzzle is never pointed at anything the shooter does not intend to shoot
- Name tent** - folded card used to identify the person sitting at that location
- Nipple pick** - tool for cleaning the opening or channel in the nipple of a muzzleloader
- Nipple wrench** - tool designed to remove or replace a nipple
- Nitro card wad** - heavy treated paper cut to shape and used as an over-powder wad in shotguns
- Notch or V-sight** - open rear sight using a notch or a V-shaped slot as a reference point for sight alignment
- NAA** - National Archery Association, the governing body for FITA-style shooting and Olympic archery in the United States
- NFAA** - National Field Archery Association, governing body for indoor and outdoor archery shooting using both conventional and compound bows in the United States

- Nocking point** - location where the arrow is placed on the string
- Nocking point indicator** - device for maintaining the proper nocking point on the middle serving of a string, commercial and homemade types available
- NRA** - National Rifle Association, the governing body for rifle, pistol, and international shotgun shooting in the United States. Founded to teach United States citizens to shoot.
- NSSA** - the National Skeeting Shooting Association, the governing body for American skeet shooting in the United States
- NSSF** - National Shooting Sports Foundation, a trade organization of the arms and ammunition manufacturers in the United States dedicated to the promotion of Shooting Sports
- Ogive** - curved surface at the front of a bullet
- Open sight** - rear sight with a flat or curved upper surface with or without a notch or groove as a reference point
- Optical sights** - sights using lenses with or without magnification
- Over-powder wad** - wad used to seal the bore and contain the gases produced by the burning powder
- Over-shot wad** - wad used in muzzleloading shotguns or roll-crimped shotshells to keep the shot in place until the charge is fired
- Overdraw** - extended shelf permitting a shorter arrow to be drawn inside the face of the bow
- Palm-rest grip** - pistol shooting grip where the supporting hand is cupped under the shooting hand
- Partridge sight** - sights using a rectangular notch in the rear sight and a flat-topped, rectangular blade for a front sight, often used on pistols
- Patch box** - inletted cover on the side of a muzzleloader stock used to carry a small supply of patches or other materials
- Patch knife** - a small knife used to trim patching materials when using a muzzleloading rifle with patched round balls
- Pattern** - cluster or cloud of projectiles fired from a shotgun using shotshells
- Pattern control** - use of chokes, buffering materials or loading techniques to modify the pattern of a shotgun
- PBA** - Professional Bowhunters Association, a bowhunting organization with a high ethical standard
- Peep sight** - rear sight consisting of a perforated disk through which the front sight is viewed, also called a receiver or aperture sight
- Pellets** - 1) projectiles developed for use in pellet rifles and pistols, consisting of a hollow-based lead cup; 2) shooter's synonym for shot in shotshells
- Penetration** - 1) depth to which a projectile will travel in a given substance before stopping, a measure of energy and momentum; 2) complex interaction of momentum, diameter, point characteristics and the medium; 3) bowhunters term for the arrow's ability to reach the vital organs of the quarry and exit the far side
- Percussion cap** - hollow cup of copper or gilding metal containing a small amount of pressure sensitive explosive, used to ignite the powder charge in percussion or caplock firearms and cap-and-ball revolvers
- Peripheral vision** - wide angle vision, seeing objects on the edges of the visual field
- Pilot hole** - hole bored into hard materials to start a screw
- Pistol grip** - downward curved gripping surface immediately behind the trigger guard on many firearms
- Pivot arm** - operating arm on a spring-powered trap

- Plinking** - shooting at safe and legal targets of opportunity; informal shooting
- Plucking** - pulling the fingers away from the string rather than relaxing them and letting the string roll away from them, a release form fault
- Point of impact** - location at which a projectile strikes another object or the surface of the earth
- Pope and Young Club** - organization that maintains record of bowhunting trophies
- Porpoising** - undulating (vertical oscillation) movement of an arrow in flight, usually indicates a form fault or improper bow tuning
- Possibles bag** - bag or pouch used by a shooter to carry all the equipment and materials that he or she “might possibly need”
- Post** - reticle using one or more pointed or flat-topped sighting devices
- Powder charge** - amount and type of powder used in a particular load
- Powder flask** - a non-sparking metal flask used to carry a supply of black powder
- Powder horn** - cow horn modified as a carrying device for black powder
- Powder measure** - calibrated volumetric device for measuring charges of powder
- Press** - 1) act of pulling the trigger back smoothly to fire the arm; 2) device for putting tension on bow limbs to relieve the pressure on the string; 3) tool used in handloading ammunition
- Priming flask** - small flask for carrying and dispensing small charges of priming powder
- Priming pan** - part of a flintlock containing the priming powder
- Prone** - rifle shooting position where the shooter lies belly down on the ground, supporting the rifle with the arms braced firmly on the ground
- Projectile** - object like an arrow, bullet, shot or stone propelled by mechanical, pneumatic or chemical forces
- Punch** - tool used to transfer the energy of a hammer or similar instrument to a small area
- Pyrodex** - black powder substitute developed by the Hogdon Powder Company
- Query** - a question or request
- Quiver** - device to hold arrows
- Ram** - rod or other device moved by mechanical, pneumatic, or hydraulic pressure within a given course or zone of travel
- Ramrod** - rod used for loading or cleaning firearms
- Range** - 1) safe shooting area; may be further defined by the rules of formal shooting games; 2) maximum distance a given projectile may travel; 3) distance to a target; 4) effective shooting distance of a projectile, firearm, or bow
- Range layout** - design of a shooting range
- Range officer** - person responsible for the safe operation of a shooting range
- Range rod** - heavy ramrod for use at a fixed location
- Range staff** - persons assisting the range officer while conducting shooting on a shooting range
- Receiver** - part of a firearm to which all other parts connect; housing for the action, fire control, and safety mechanisms
- Receiver sight** - aperture rear sight or peep sight
- Recoil** - reaction of the firearm to the force of a projectile being fired; expression of Newton’s law: for every action there is an equal and opposite reaction
- Recoil control** - stock construction, action design, structures or mechanical devices designed to reduce the amount of felt recoil or to spread it over a longer time frame
- Recoil pad** - hollow or solid attachment to the butt of a firearm used to cushion the recoil
- Record shot** - shots fired at the scoring surfaces of a target
- Recurve bow** - conventional bow with the tips of the limb curved toward the back of the bow
- Reflexed limb** - limb that angles toward the back of the bow when the bow is unstrung

- Release** - 1) permitting the bowstring to return to its resting position, firing an arrow; 2) hand-held mechanical device to fire the bow
- Reloading** - handloading, remanufacture of ammunition from basic components
- Report** - firing noises produced by a firearm
- Reticle** - sighting device or structure
- Rifling** - spirally arranged lands and grooves that impart a spin to the projectile or modify the dispersal of shot
- Rifling process** - cutting grooves in the interior of a firearm bore to create rifling
- Rim** - flange at the base of a cartridge case; may be used as a location for a priming compound (rimfire cartridges) or for headspacing and extraction purposes
- Rimfire** - cartridge with priming compound sandwiched between the layers of a folded rim, fired by striking the rim and crushing the priming compound between the metal surfaces
- Riser** - central portion of the bow, including the handle or grip
- SAAMI** - Sporting Arms and Ammunition Manufacturer's Institute, the industry-supported organization that sets standards for the sporting arms and ammunition industry
- Sabot** - a split sleeve to hold a bullet or ball
- St. Charles quiver** - hooded quiver worn in the center of the back and permitting the arrows to be removed from the bottom of the quiver
- Scattergun** - term used for shotgun
- Screw-in adapter** - 1) device permitting quick change of points having threaded shanks; 2) accessory attachment points on the riser of the bow
- Sear** - interlocking surfaces that hold a mainspring, hammer, firing pin, or similar device in place until released by moving the mating surface
- Sear spring** - spring that holds a sear in place
- Self bow** - bow built as a single unit
- Semi-automatic (semi-auto)** - self-loading firearm design in which some of the energy developed by the fired cartridge is used to operate the action; may be operated by gas or recoil
- Semi-beavertail forend** - forend intermediate in design between the beavertail and splinter designs
- Serving** - windings placed on a bowstring to protect the string loops and the center portion of the string and to provide a smooth surface for a cleaner release
- Set trigger** - trigger used to activate a hair-trigger sensitivity on a firing trigger in a double-set trigger arrangement
- Shaft** - body of an arrow
- Shaft spider** - tracking device inserted in a hunting arrow that leaves a trail of fine thread to aid in game recovery
- Shaving lead** - leaving small shavings or splatterings of lead around the forcing cone of a cap-and-ball revolver
- Shooting range** - 1) safe place to shoot; 2) shooting field or location developed according to the rules of a specific event
- Shot charge** - weight of shot in a shotshell
- Shot cloud** - airborne shot charge or shot cluster
- Sight** - device to assist in aligning the eye with the bore or bow and pointing the aligned system at a target
- Sight bar** - vertical post allowing for elevation adjustment
- Sight extension** - horizontal bar extending the sighting radius for more precise sight alignment

Sight picture - combination of a properly aligned set of sights and a target

Sight pin - post, pin, or other shape used as the actual sighting device

Sight window - cutout area on a bow to permit the arrow a straighter path to the target and to permit the use of a sight

Sighting ring - ring around the bulls used for sighting shots

Sighter - shots fired to determine and adjust sight settings

Sighter bull - bull used for sight adjustment

Signature - personalized indicia on the shaft just beyond the fletching to identify or beautify the arrow

Silhouette shooting - shooting games where metallic silhouettes are the targets and knocking them over is the criterion for success

Silencer - device designed to reduce noise by dampening vibrations of the string or cables or by muffling the report of fixed breech firearms

Sin - arrow falling short of the target

Single stage trigger - normal single trigger

Sitting - shooting position where the shooter sits on the ground supporting the elbows with the knees

Six o'clock hold - hold where the bull is situated at the top of the front sight (like a "pumpkin on a post") in order for the projectile to strike the center of the bull

Skeet - 1) formal shotgun shooting game conducted on a nearly semi-circular field with eight shooting stations around the perimeter and targets thrown from either end of the base chord; 2) shotgun choke producing patterns of about 35 to 40 percent of the shot in a 30-inch circle at 40 yards, also known as skeet 1; 3) skeet 2 chokes fire tighter (nearly modified) patterns

Skirt - hollow rear portion of a pellet

Slap - 1) arrow striking the cables, riser or rest on the release resulting in fish-tailing; 2) string striking the inside of the forearm or elbow of the bow hand, usually indicating pronation of the shoulder or improper elbow rotation

Sling - 1) strap used to carry a firearm or steady it in some shooting positions; 2) strap used to hold the bow in the shooter's hand on release of the arrow

Smoothbore - firearm lacking in rifling

Snap caps - inert devices designed to fit a firearm chamber and permit it to be "fired" releasing the tension on the springs without damaging the firing mechanism

Snatching - jerking the trigger to make the firearm fire while it seems to be lined up with the intended point of impact

Spin wing - light plastic vane with a curled edge used by many target archers

Spine - stiffness of the shaft, a feature of its materials, length, diameter, mass, wall thickness and accessories

Spitzer - sharply pointed bullet with a tangent or secant ogive

Splinter forend - thin forend or fore arm found on many side-by-side double shotguns

Sprue - small projection left when a cast round ball is molded

Squeeze - act of pressing the trigger straight back with steady pressure until the firearm goes off

Squib load - grossly under-powered load

Stabilizer - counter-weight(s) attached to the bow to dampen vibrations during release

Stadia wires - multiple cross hairs used as a range finding device in some optical sights

Stalker quiver - hip quiver designed to protect broadheads from damage and the shooter from broadhead injuries

Standing - shooting position where the shooter stands upright and supports the firearm with the

arms and shoulder alone

Starter - see ball starter

Station - shooting position or location on a shotgun field; trap has five stations, skeet has eight

Statistical office - location of the statistical officers

String - 1) bowstring; 2) series of shots fired with the same sight setting and hold; 3) series of shots fired in accordance with the rules or the orders of the range officer

String hand - drawing hand, the hand on the same side as the dominant eye

String hand side - the dominant-eye side of the body, bow or target

String jig - device used for making bowstrings

String nock - notches cut in the tips of the bow's limbs to hold the string in place

String peep - aperture rear sight anchored in the upper part of the bowstring

String silencer - device to reduce string vibrations and string noise on shooting

String tracker - any of several tracking devices used by bowhunters to aid in recovering game animals

Stock - wooden or composite materials acting as a handle for the firearm

Straight-away target - target flying on a line directly away from the shooter

Straight grip - firearm grip or wrist that follows the straight line from the toe to the trigger guard; also known as an English grip

Straight stock - butt stock with relatively little drop at the comb or the heel; tends to recoil nearly straight back and to pitch the shots somewhat high; commonly used on trap guns

Sustained lead - shotgun lead obtained by maintaining a set gap between the shotgun and the target (towing the target along with the shotgun)

Swing through lead - shotgun lead obtained by starting behind the target, accelerating through it and firing as the muzzle clears the front of the target

Tab - protective device for the shooting fingers, composed of one or more layers of material

Take - process of rendering game animals into the possession of the hunter, broadly defined by most game agencies

Take-down bow - bow that permits the limbs to be removed from the riser for transportation or storage; also permits use of different weight limbs or replacement limbs

Tang - metal extension of the action, trigger guard, receiver, breech plug, or other part bedded into the stock

Tang lever - operating lever of a single-shot or double-barrel firearm

Target back - reverse side of the target from the one with the bulls printed on it

Target panic - inability to release the bowstring when the arrow or sight is properly aligned with the target

Telescope sight - optic sight with or without magnifying lenses, adjusted either internally or externally and containing a reticle or sighting device

Thimble - cylindrical support structure on a muzzleloader to hold the ramrod

Three position - shooting match including stages fired from the prone, standing and kneeling positions

Thrower arm - cushioned arm that propels clay targets from a trap

Thumb-lock grip - pistol shooting grip where the fingers and thumb of the supporting hand are wrapped over the fingers and the thumb of the shooting hand

Tight group - obviously compact cluster of shots fired with the same sight setting, sight alignment, and sight picture and demonstrating proper form

Toe - bottom edge of the butt of the firearm

Touch hole - the opening in a matchlock arm where the match was inserted into the powder

charge

Tracking the target - moving the firearm along the flight path of the target

Trade gun - smoothbore muzzleloader used as a trade item during the fur trade era

Trajectory - the curved flight path of the arrow or other projectile

Trajectory curve - path of a projectile in flight relative to a line of sight

Trap - 1) a device for throwing a clay target; 2) a formal shooting game

Trap field - field properly set up for shooting trap

Tree sight - specialized sight that compensates for the downward angle of the bow when shooting with the arm lowered rather than extended straight from the shoulder

Triangulation - using a series of three or more “shots” to determine the precision of a shooter’s sight alignment

Trigger - lever used to release a sear and fire a firearm

Trigger control - 1) keeping the finger off the trigger except during a shot; 2) pressing the trigger straight back through a firing sequence without disturbing the sight alignment and sight picture

Trigger guard - protective device surrounding the trigger

Trigger plate - metal plate that controls the orientation of the trigger

True draw length - distance from the string to the far edge of the arrow rest

Tumbler - device in a muzzleloader lock that permits the hammer to fall on firing

Two-wheel bow - compound bow design featuring eccentric wheels or cams at end of both limbs and without idlers, usually features more let-off at full draw than a four-wheel bow

Uncalibrated - having divisions that are of unequal or unknown units

Unhit bull - record bull that has not been fired upon or hit by a shot, usually associated with failure to fire at a bull and firing at another bull more than once

Vane - 1) individual piece of fletching material; 2) plastic fletching material

Vernier peep - an adjustable peep or receiver sight used on long range or target muzzleloading rifles and adjusted on a Vernier scale

Wad - material used to seal a bore, to cushion a shot charge or projectile or to prevent shell components from moving within the case, usually made of treated paper (card wads), fiber, felt or plastic

Wad column - total array of wads in a cartridge or charge

Web - portion of hand between the base of index finger and the base of thumb

Wedge pin - see barrel wedge

Wheel lock - 1) firearm lock using a spring-loaded, serrated wheel whirling against a pyrite flint to produce a shower of sparks and ignite a priming powder charge; 2) a firearm with a wheel lock action

Whip finish - winding a strand of material over itself to lock the end in place, usually accomplished by winding the material over a loop of strong material, tucking the end of the wound material through the loop and pulling the loop out, drawing the material under itself

Wobble area - area through which a firearm moves during sighting and firing

Worm - spirally twisted metal pins used for retrieving patches or swabbing the bore with cleaning patches when using a muzzleloader

Wrist - the narrow portion of the stock at the grip

Zone of fire - the danger area ahead of the muzzle, must be safe before any shooting equipment can be discharged safely



Extension - 4-H Youth
Development



It is the policy of Purdue University that all persons have equal opportunity and access to its educational programs, services, activities, and facilities without regard to race, religion, color, sex, age, national origin or ancestry, marital status, parental status, sexual orientation, disability or status as a veteran. Purdue University is an Affirmative Action institution. This material may be available in alternative formats.

Revised March, 2022