

# Montgomery County



4-H



## Gift Wrapping





## General Information

1. In **ALL** divisions, packages are **NOT** to exceed 18 inches in **ANY** direction.
2. Packages for exhibit should be empty.
3. Purchased bows will **NOT** be acceptable.
4. You must **CREATE** a gift card and attach it as you would on a regular gift instead of on the bottom of the package.
5. A completed record sheet **MUST** accompany the exhibit.
6. Refer to "**Ready, Sew..Wrap**" (page 4-17) for helpful hints.

Books are available at your local library which includes information about wrapping packages.

These are good supplemental resources to the information contained in this manual. Ask your librarian for help in finding such books.

**Purpose:**

**Grade 3**

To learn the proper method and techniques for wrapping a simple package (square or rectangle in shape). To learn how to make simple package bows using any type ribbon. **DO NOT use a bow maker.**

**Project Requirements:**

Wrap 5 square or rectangular packages during the year, NOT including your exhibit, using purchased wrapping paper. Make your own simple bows for your packages.

**Exhibit Requirements:**

- a) Exhibit 1 wrapped package not to exceed 18" in length or width. Package should have a self-made bow.
- b) A completed record sheet for this project.

**Grade 4**

**Purpose:**

Learn to be creative and to design your own ideas into an attractive gift.

**Exhibit Requirements:**

- a) Exhibit 1 gift bag creating your own bag or using a plain, purchased bag. You **MUST** add your own decorations. Attach a self-made gift card to the handle with required information on it.
- b) A completed record sheet for this project.

**Grade 5**

**Purpose:**

Learn to wrap gift packages using materials other than purchased gift wrap. Learn to use a variety of materials for the package trim **OTHER** than bows.

**Project Requirements:**

Wrap 6 packages during the year using the techniques you have learned in the previous division of this project. Wrap 4 gift packages during the year, NOT including your exhibit using wrapping materials other than gift wrap (i.e. burlap, fabrics, scarves, towels, newsprint, etc.).

**Exhibit Requirements:**

- a) Exhibit 1 wrapped gift package (no larger than 18" x 18" x 18") using any material other than purchased gift wrap and ribbon. Judging will include the originality and creativity of the exhibit as well as the techniques used.
- b) A completed record sheet for this project.

## Grade 6

### Purpose:

Learn to wrap cylinder shaped packages.

### Project Requirements:

Wrap 2 square or rectangular packages and 4 cylinder shaped packages during the year, NOT including your exhibit, using purchased wrapping paper. DO NOT use a bow maker. See page 16 for specific guidelines.

### Exhibit Requirements:

- a) Exhibit 1 wrapped cylinder shaped gift package. Show creativity in your exhibit.
- b) A completed record sheet for this project.

## Grade 7

### Purpose:

Learn to wrap gift packages with the top of the package wrapped separately from the bottom. Learn to fold and place tissue liners in packages for clothing gifts; and proper use of tissue as a protector for gifts. Experiment with incorporating unique ideas in gift wrapping by using such items as flowers, toys, kitchen utensils, etc. either alone or with a self made bow. **DO NOT use a bow maker.**

### Project Requirements:

Wrap 4 packages during the year using the techniques you have learned in the previous two divisions. Wrap 5 packages during the year, NOT including your exhibit, with the package top wrapped separately from the bottom and containing a tissue liner. See page 17 for specific guidelines.

### Exhibit Requirements:

- a) Exhibit 1 wrapped gift package (no larger than 18" x 18" x 18") using the skills you have learned this year. The gift package top must be wrapped separately from the bottom and must contain a tissue liner. Show creativity in the uses of package design and trim. The package will be judged on the inside appearance as well as the outside wrapping.
- b) A completed record sheet for this project.

## *Grades 8 & Up*

### Purpose:

Learn to design and make your own wrapping paper (i.e. roller painting, string pulling, dip dying, stenciling, etc.). Continue to experiment with trims other than bows.

### Project Requirements:

Wrap 10 gift packages during the year, NOT including your exhibit. At least one half of those packages MUST be wrapped with paper you have designed. See pages 18 through 20 for specific guidelines.

### Exhibit Requirements:

- a) Exhibit 1 wrapped gift package of any shape. You MUST design your own wrapping paper. Use creativity in developing the desired effect with self made wrapping. Trims may be of your own design or of materials compatible with the paper. Package should have a self made bow compatible with the paper. (No bow maker and be creative.)
- b) A completed record sheet for this project.

# Ready, Set... Wrap

Points to consider when preparing your exhibit for judging are: Neatness (corner paper, tape, trim, and/or bow) color, and material coordination; theme carried out; creativity and originality.

## Box Selection

The wrapping of a gift begins with preparing the gift to be wrapped. Putting the gift in a box enables the giver to wrap the box with greater ease. Most articles need to be put in a box to maintain the gift's shape, or because the article has an unusual shape.

In selecting a box, you should follow these guidelines:

1. Select a clean box, in good condition.
2. The box should be sturdy with straight comers.
3. The gift should fit the box, leaving only a small amount of space between the box and gift.
4. The box should be well-shaped. Odd shaped boxes are difficult to wrap. Common box shapes are rectangular, square, and cylindrical.

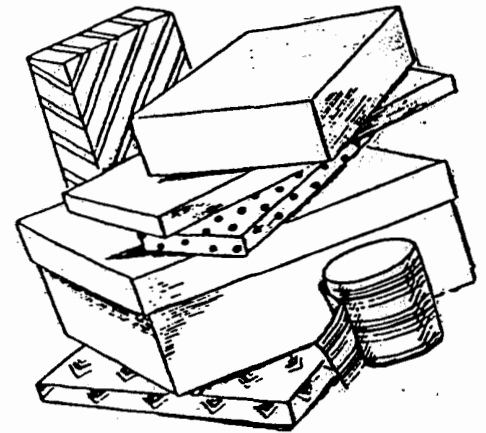

After the box has been selected, white or pastel tissue paper should be placed in the box before the gift. The paper should cover the bottom of the box and completely cover the top of the gift.

- a. Items such as clothing should have one or two pieces of tissue paper, folded in the center and placed in the box before the article is put in. Often a combination of both procedures can be used to make your package neat on the inside.

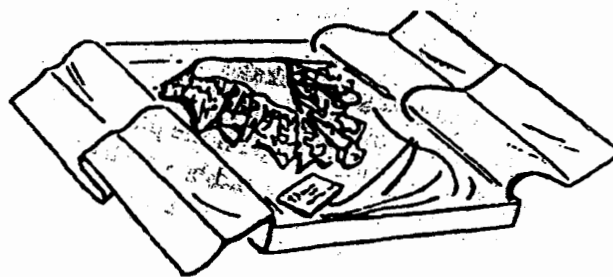

- b. With toys or other household articles; small pieces of tissue paper should be crumpled and placed at proper points so that the item wont break or rattle.

## *Selection of Wrapping Paper*

When you select the giftwrapping paper, you need to ask yourself these questions:

1. What paper is available?
2. Is there enough paper to wrap the gift?
3. Does the paper suit the occasion?
4. Does the paper take into account the age and gender of the receiver?
5. Is the design in proportion with the size of the box?

Once the paper has been selected, you can continue with the wrapping of the gift. The shape of the box dictates how you will wrap the gift.

## *Selecting Wrapping Materials (Other than paper)*

- A. Decide on gift and occasion before selecting your wrapping material.
- B. Wrapping materials should suit the gift.
- C. List of suggested wrapping materials include:

Socks	Scarves
Bath towels	Burlap bags
Dishtowels	Onion sacks
Washcloths	Yarn

# Wrapping Your Gift

## Rectangle and Square

1. Estimate the amount of paper required to go completely around the box plus an overlap. Allow an overlap so the paper can reach a little over half the width of the open ends.
2. Place the gift upside down on the open sheet of gift wrap centering the paper design.
3. Tape the paper in place on top (will be bottom of gift when finished).
4. Beginning on one end, (a) the top flap is folded down toward the center (b) both side flaps are then folded toward the center (c) the bottom flap is brought up and taped in place.
5. The procedure is repeated on the other side. Always be sure that the paper is kept tight.
6. Turn the package over so that the smooth side is on top.

NOTE: Folding a small amount under makes for a neater package.  
(see illustrations a - c)

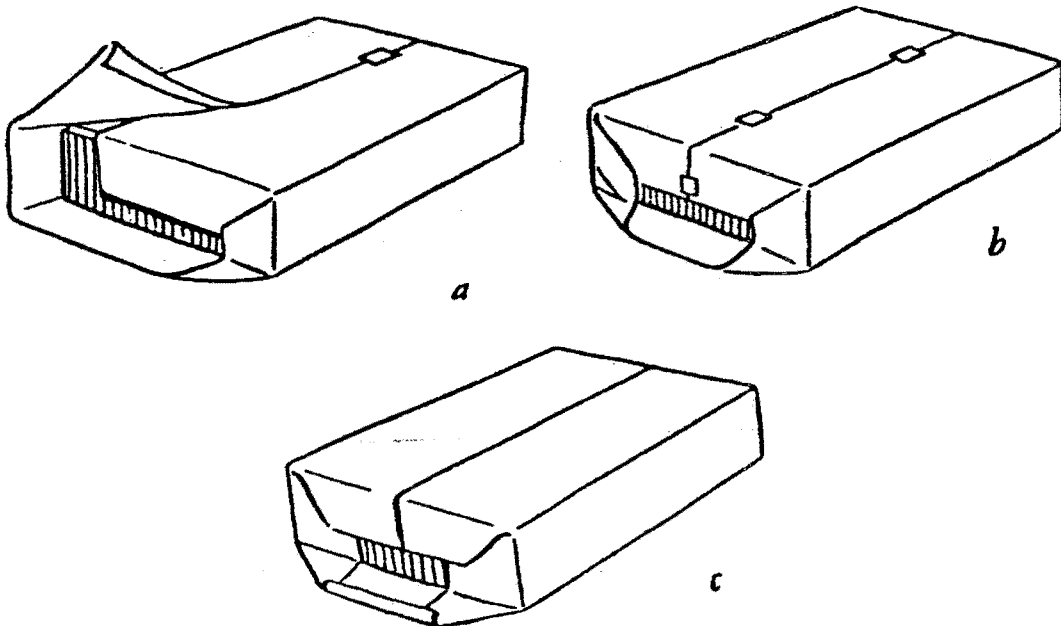

## Decorating Your Package

Now that the gift has been wrapped, it is time to think about the types of bows and decoration that can be used on your gift. You want each package to have its own personality.

The ribbon selected should compliment the wrapping paper that you used. Color can either contrast or match. One thing you must remember is that often simplicity is the most attractive. Too much design or trim can be distracting. Many types of ribbons, yarns and cords are available. Use your imagination to let your gift wrapping express the sentiments of the occasion as well as the personality of the giver.

The decoration of the gift is complete when wrapping paper, bows and/or decoration is combined effectively to create a pleasing overall appearance. Ribbon is usually wrapped around the box to which the bow is attached. Ribbon can be placed at corners (1) the length (2) or width (3) of the box. It can also be repeated several times. The ribbon must always be secure. A loose ribbon can ruin the appearance of a pretty package. The bow is then either tied or pasted to the package.

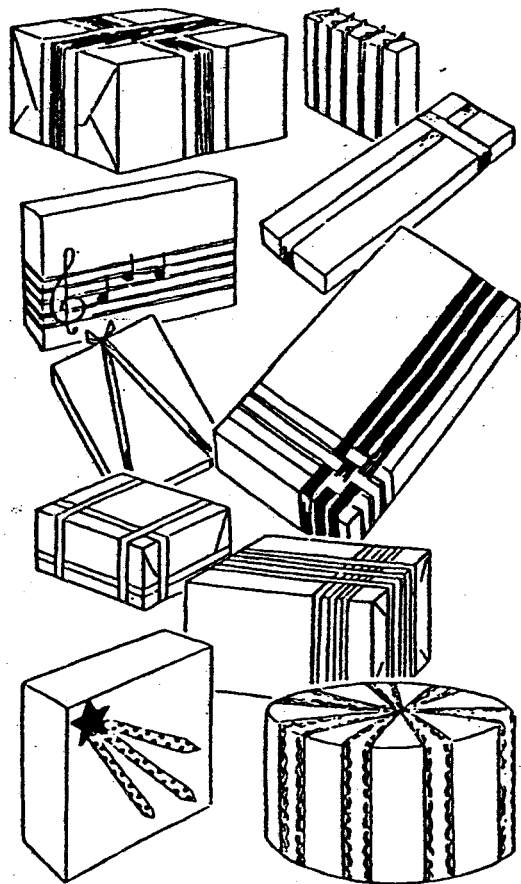
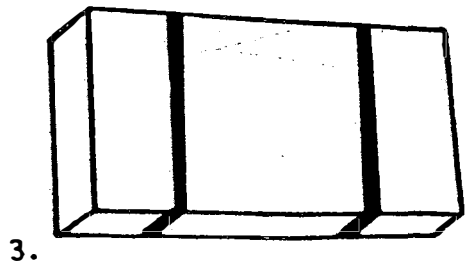
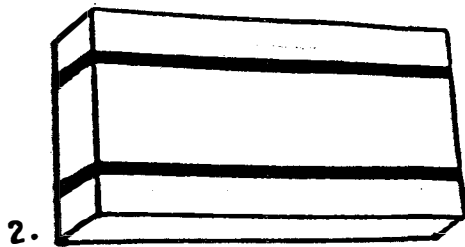
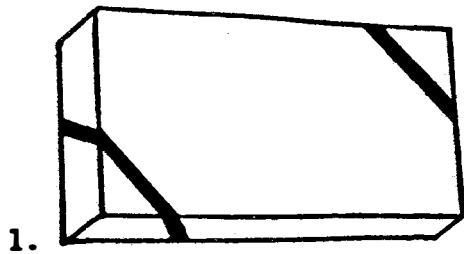

## **Bows**

There are many different ways of making bows. The following are suggestions. Use your imagination and create different types.

### **Loop Bow**

The loop bow resembles a wheel. It requires two yards of 1/2 inch ribbon preferably firm or stiff, such as cellophane, laminated, metallic, grosgrain, or ribbonette. Ribbon must be alike on both sides.

Make a 3 or 4 inch loop about 5 or 6 inches from one end as shown in illustration (a). Do not pinch

together. Continue looping ribbon back and forth, making each loop directly under the one above, until you have made fourteen to sixteen loops. Wind fine wire around center, taking care not to crush edges (b). Lay on package and spread loops apart at center to form a perfect circle. Fasten to box by pinning through the center, or use tape.

The circle effect may also be obtained by making two bows of fewer loops each, and joining them back to back on the package to form the circle (c).

### **Variation 1 (Fig. 1)**

Turn loop inside out by pushing bottom edge of loop into center, bringing up and back to original position.

### **Variation 2 (Fig. 2)**

If ribbon has a right and wrong side, place two different colors of the same width ribbon with wrong sides together and make bow as shown.

### **Variation 3 (Fig. 3)**

Push loop in toward center. Push top edge down and under so that it turns inside out, to give the twisted effect as shown. Use ribbonette or crinkle-tie.

#### Variation 4 (two-in-one)

Lay narrow ribbon on top of a different color or kind of ribbon in a wider width (a) and form a bow (b) in any of the previous variations. This will result in an interesting difference between the top and bottom loops (c).

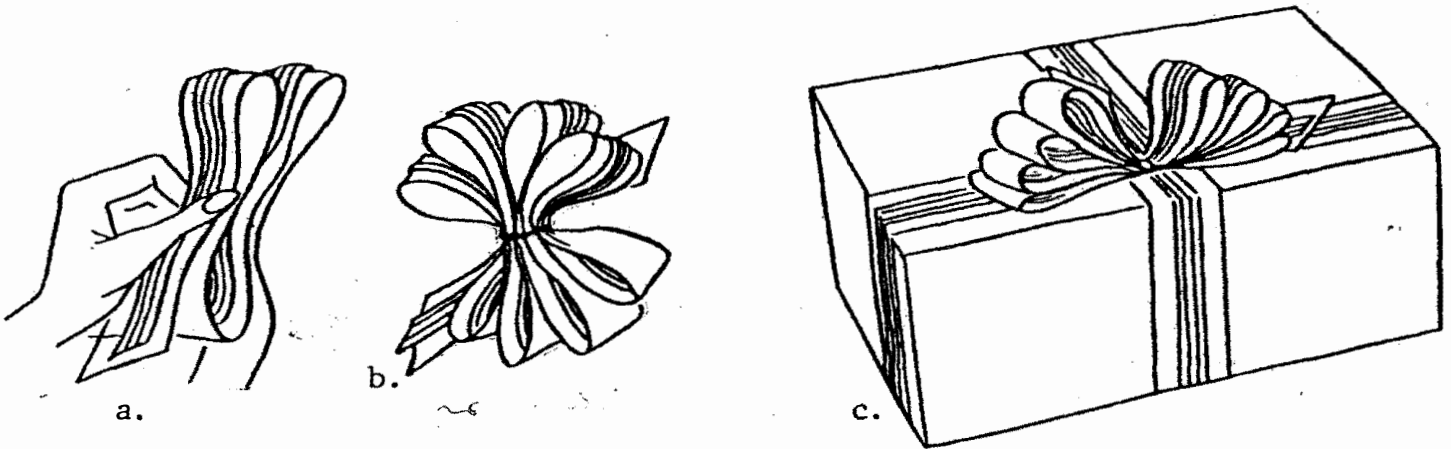

#### Variation 5 (graduated loops)

When making this version, start with a short loop and make each succeeding loop a little longer. You can use Fig. 1 as a guide, but do as instructed here, tying in center.

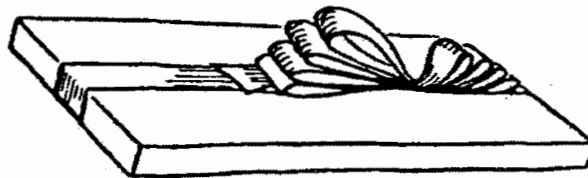

#### Variation 6 (layer bow)

For this bow, ribbon must be alike on both sides {moire, grosgrain, metallic, tinsel, double-faced satin). Lay ribbon on a flat surface and fold loops back and forth on top of one another (a), making each one shorter than the one beneath. Tie firmly around center and attach to package. One and a quarter yards of ribbon will make a nice bow which has three loops on each side as shown in (b).

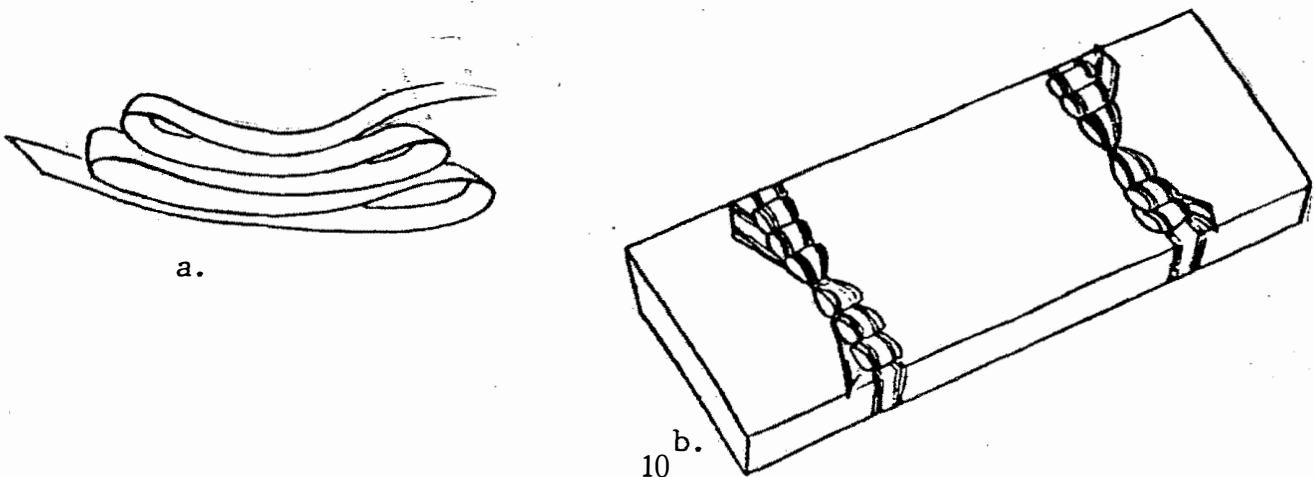

## Hair Bow

Place ribbon in S or double-S shape, keeping right side up (a). Cover with open hand and gather ribbons together between first and second fingers (b). Tie in center (c) and attach to package (d).

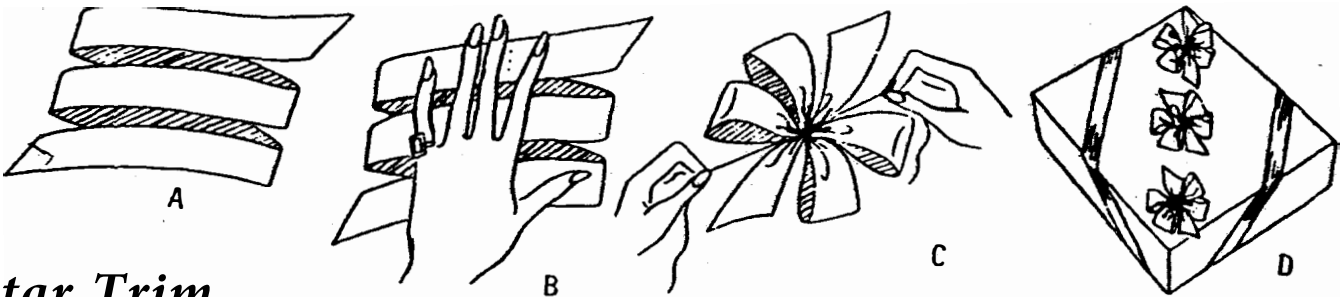

## Star Trim

Use 1 1/2 inch width ribbon. Cut 4 inch pieces (a) and fold in funnel shape by lapping ends to form petals (b). Arrange petals to form a star and stitch ends together (c). This is novel on packages and also makes a pretty place card at a party table. It may be filled with candy (d) or ornaments.



## Pussy Cat Bow

To make this bow, cross ends over as shown (a). Wind center with thread or wire (b). If desired, center may be covered with narrow baby ribbon of matching or contrasting color and an ornament tied in (c).

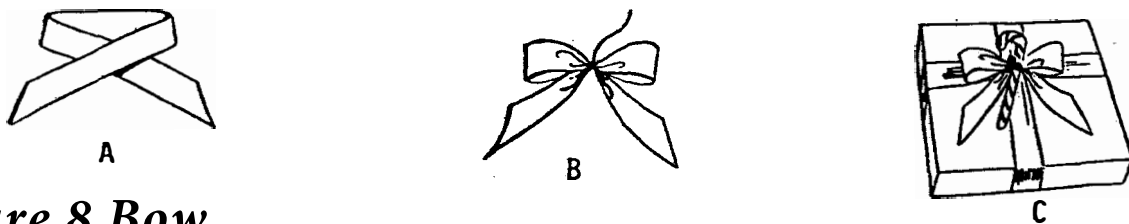

## Figure 8 Bow

Work ribbon back and forth in loops in the form of a figure 8. Use a ribbon with a firm body. You may find it easier to make the bow in reverse position. Turn the bow (as shown) upside down and make the figure 8 small to start with making each one successively larger.



## Glamour Bow

2 3/4 yards of 2-inch ribbon are needed to make bow shown here. 3 1/2 inches from one end, pinch gathers in ribbon and hold between thumb and fingers of left hand. Seven inches from this point, pinch gathers again and bring up to first gathers to form a loop 3 1/2 inches long as shown (a). If ribbon has a right and wrong side, keep right side out by turning ribbon under thumb and fingers as loops are made. With right hand, continue making loops in the same way (b) until you have twelve loops (six up and six down) and an extra end about 3 1/2 inches long. Wind wire or thread around gathers to hold them in place.

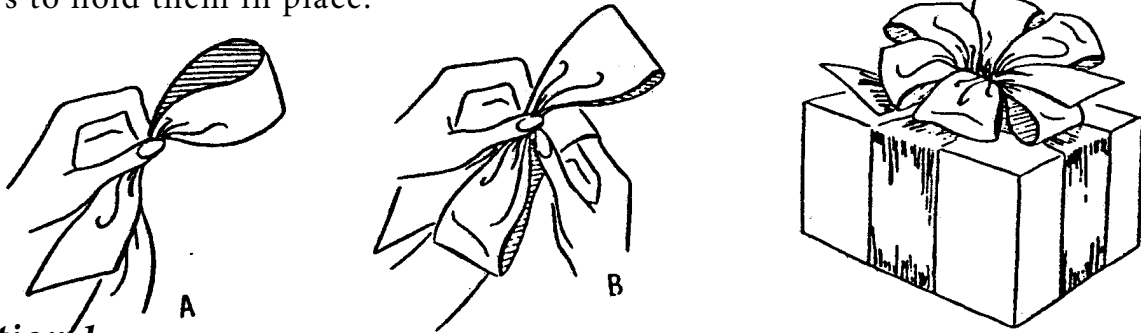

### Variation 1:

Carriage bow (Fig. 1) - Use 3-inch ribbon and make a glamour bow which has only six loops and two ends. Tie in center with narrow ribbon and arrange loops to form a circle. Make a second bow (using same or contrasting color) having only four loops and lay it on the top of the first bow (center on center). Tie double bow (Fig. 2) by using a different kind of ribbon for the smaller, center bow.

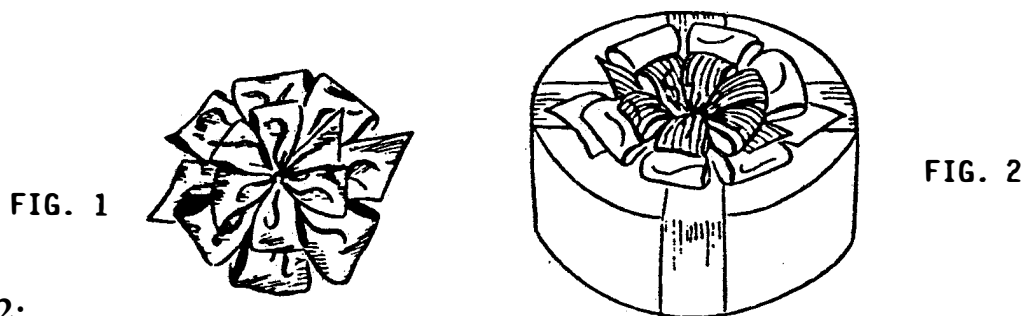

### Variation 2:

Knotted bow - Use 1 1/2 - 2 inches wide and about 2 yards long. Mark a mark every 10 inches.

- Tie a soft loose knot at every other mark
- Pinch gathers on the mark between knots and make loops same as the original glamour bow (knot should come at the center of the loop).

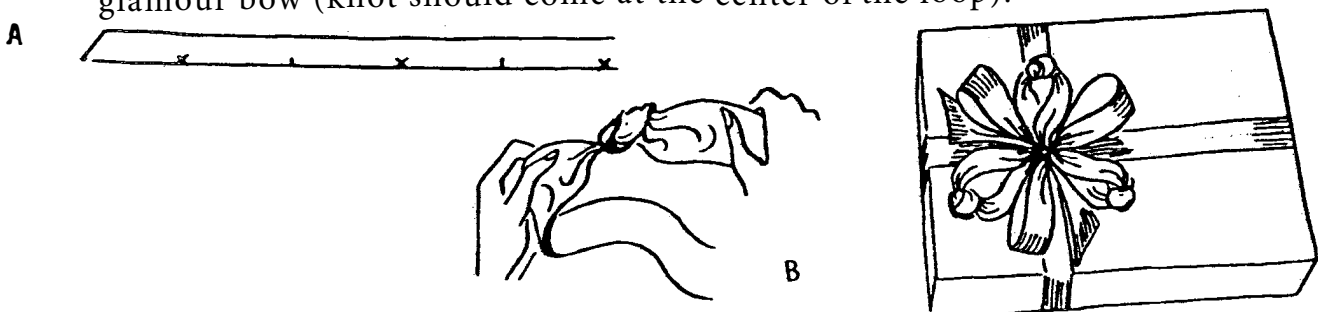

## Basket Bow

Make a loop at one end of a piece of ribbon and wind with strong thread or soft fine wire (do not break thread). Make a second loop next to the first one (loops will be 1/2 to 3/4 inches apart) and wind with same thread as used on first loop (a). As each loop is made, push it away under palm of left hand and proceed with the next one. Continue winding loops in this manner until desire number of loops have been made (about ten to fifteen). Do not cut thread yet. Now you will have a continuous row of loops. Wind them into a circle so that all stand upright. To hold them in this position, wind them together with the thread in and out between loops (b), then tie thread or wire and leave ends for attaching to package.

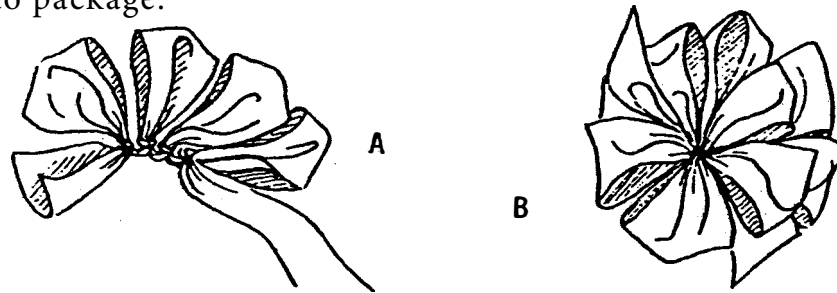

## Pin on Bow

Use 24 inches of ribbon and make a loop 3 inches long about 3 or 4 inches from one end. Pinch gathers (a) and hold between thumb and finger of right hand. Pick up longer end near this point and bring it around under finger of right hand and up over fingernail and the ribbon that covers it. Catch loop this formed with right thumb and finger as you let go of the first loop. Pull both loops to tighten.

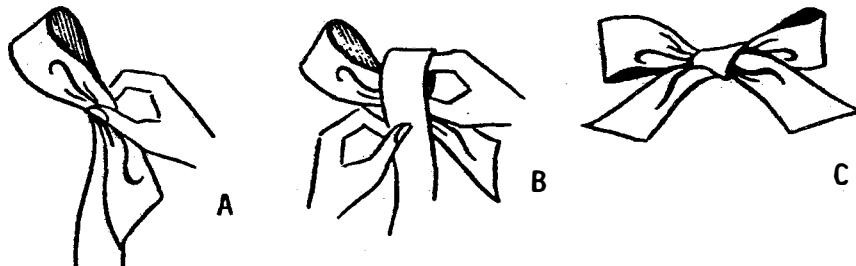

## Variation:

Fold a half yard length of ribbon as shown in illustration (a). Bring end on left up over the center (b) and around and behind both layers of ribbon, then down. Tie both ends in a single knot. This makes a decorative twisted knot (c) which is particularly pretty when made with a two-tone satin ribbon. The pin-on bow is particularly suitable for sewing on lingerie, dolls' clothes, handkerchief comers, baby clothes, etc. before placing in gift box.

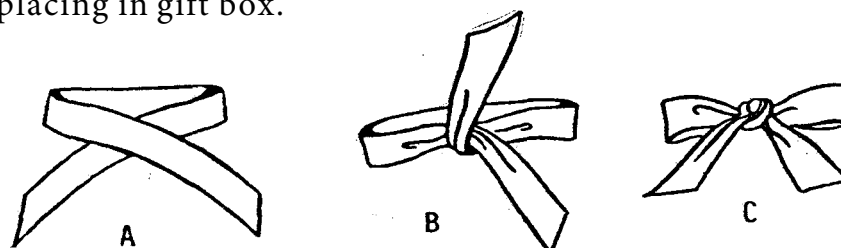

## Poinsettia Bow

For a medium-sized poinsettia bow, use ribbon between 2 and 3 inches wide. Use a red satin ribbon with a very crisp finish. If the ribbon is 2 inches wide, measure off with pins along selvage at 2 inch spaces the whole length of the ribbon; if 2 inches wide, the pins should be placed 3 inches apart. Next, cut across on diagonal lines to form petals as shown (a).

Pinch gathers along straight grain of ribbon as indicated by dotted lines (b). Hold gathers in place by twisting tightly with thread. Arrange three petals to form a six-pointed flower (c). Fill in center with a knot of yellow baby ribbon or with a yellow flower center.

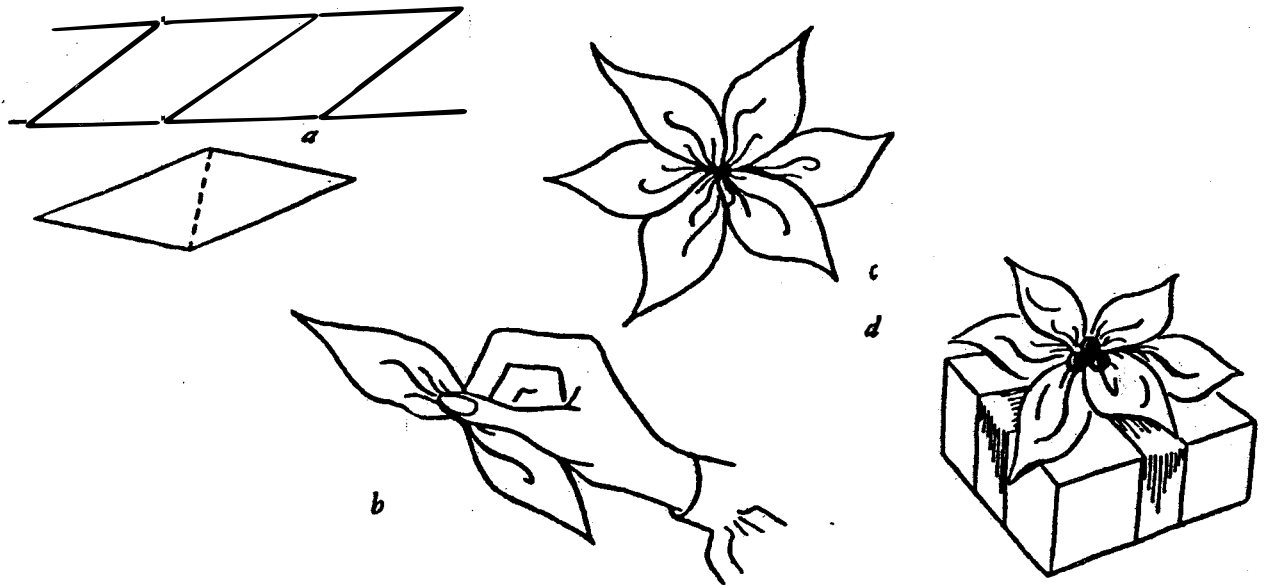

## Curled & Knotted Trim

Tinsel or paper type ribbon may be curled by drawing it over the back of a knife blade. Tie a knot in the center of short lengths of ribbon and pin or tape to package.

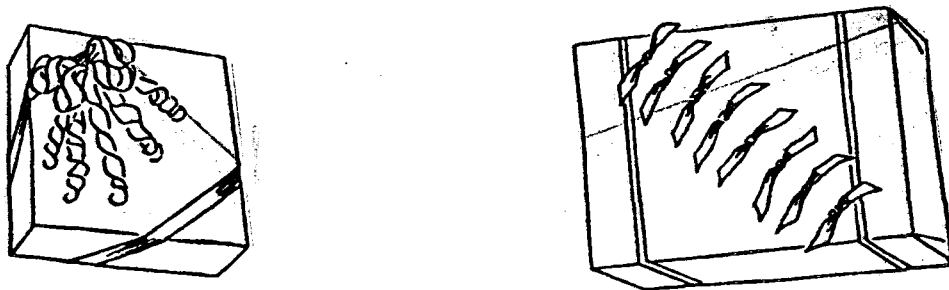

## Wreath Bow

The wreath bow requires 2 1/2 yards of ribbon 4 or 5 inches wide. Cut the ribbon into the following lengths: 16 inches, 20 inches, and 24 inches. The 30 inch piece remaining is used for ends. Fold ends of each piece to the center, overlap, and hold in place with two or three stitches as shown in illustration

- Arrange loops in layers and pinch all centers together
- Tie securely with narrow ribbon or wire. Tie the 30 inch piece around the center, knotting it in back, and allow ends to fall as streamers
- You can also use only one or two loops if you prefer.

The *Glamour Bow* made with only two or four loops, may also be used as a wreath bow by the addition of long streamer ends.

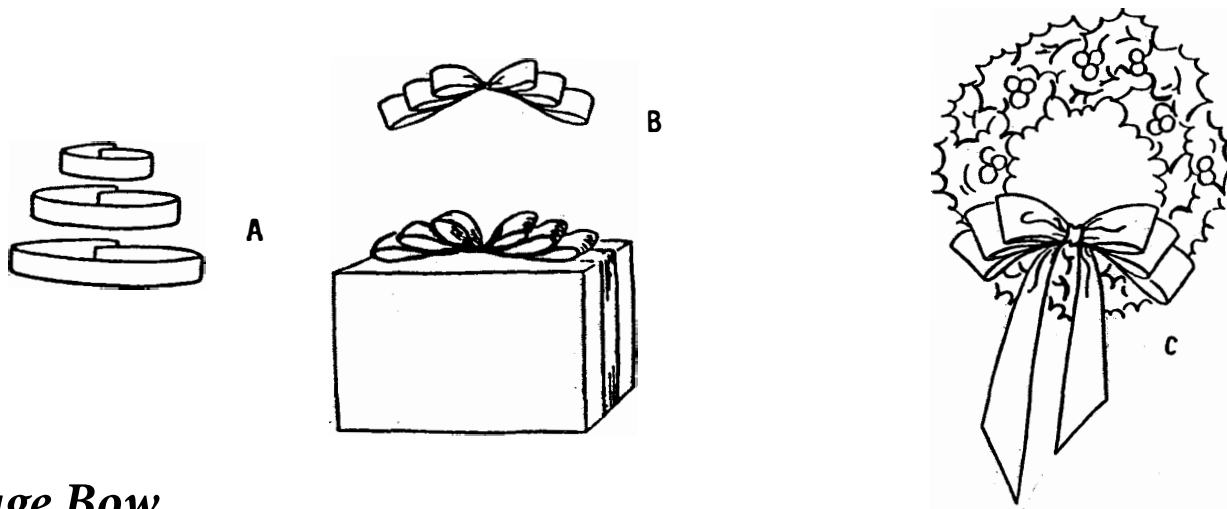

## Corsage Bow

Hold ribbon between thumb and first finger of left hand, allowing end to extend 3 or 4 inches as shown in illustration

- With right hand, bring ribbon over thumbnail and around and under thumb
- Then proceed to make loops as for the *Glamour Bow*
- Make 10 or 12 loops. Next insert a piece of wire under the ribbon
- Slip thumb out of loop and twist wire tightly. The center this made on the corsage bow is its chief attraction.

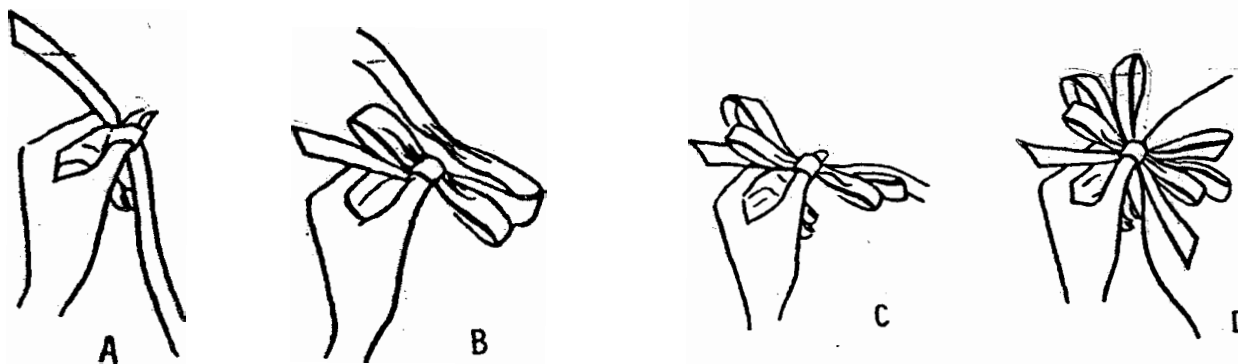

## Greek Bow

Long ago the Greeks devised a simple arrangement of ribbon loops which is now generally used with floral decorations and is called the Greek bow.

Cut 4-inch-width (or wider) ribbon in 6 or 7 inch lengths. Gather ends and bring together to form a loop. Wind with wire to hold. Allow the end of the wire to extend as a stem. This makes one petal. Cover wire and base of petal with green mending tissue. (Florists have this; so do craft supply houses - - any place where material for making artificial flowers is sold.) When several are combined, they make an upstanding bow that is particularly effective in baskets of flowers or potted plants.

A variation of this type of bow has ends instead of loops. To make it, cut wide Ninon or gauzy-type ribbon into squares. Pinch center of square so that all edges stand upright. Twist wire tightly around pinched portion and in the center of the square. It will be easier to twist wire around it and the wire cannot pull off. Edges may be fringed or cut with pinking shears. Changeable taffeta squares, fringed on edges make a pretty trim.

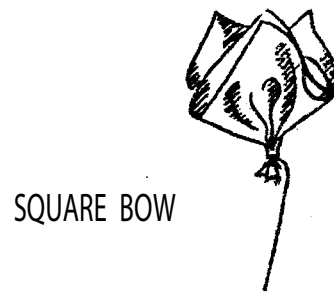
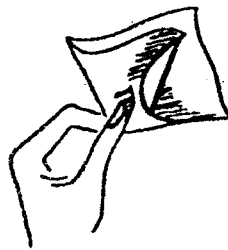

From 1-inch ribbon, cut 4 pieces, each 5 1/2 inches long. Wind thread around center of each piece and tie tightly. Arrange tie four pieces in wheel form and tie together. Cut ends diagonally, in fishtail shape or with pinking shears.

### BOW OF ENDS

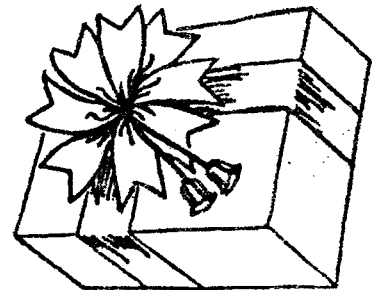
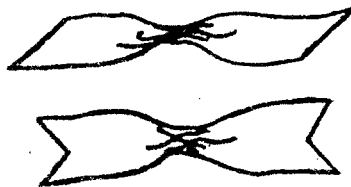
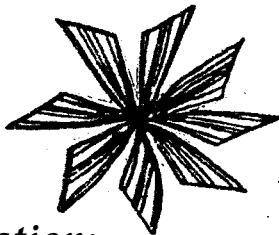

#### Variation:

(bow of ends)-Cut ribbon into short lengths. Group five to six pieces (or ten double length) together, and wind wire around the center. Ends may be fringed or notched. If tinsel or crinkle tie is used, the ends may be curled. To curl, press ribbon on dull knife blade and pull knife along under each piece. Odds and ends of various colors and kinds of ribbon may be combined to make effective use of leftovers.

## Cylinder (Grade 6)

### **For Smooth ends.....**

1. Trace ends of the cylinder and cut out two circles of the wrapping paper.
2. Wrap the cylinder with wrapping paper, allowing an overlap on both ends. Tape securely.
3. Fold the overlap at the ends (cutting sometimes is necessary) and paste down (be careful to not get paste on the gift).
4. Paste circles over folds. A decorative seal may be used in place of the circle.

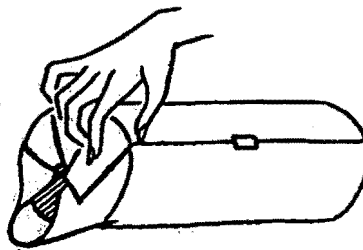

### **For Fringed ends.....**

1. Wrap the gift in wrapping paper allowing enough for the ends to be gathered and tied. Tape securely in middle of paper.
2. Gather paper at ends and tie securely.
3. Cut ends in strips to make fringe.

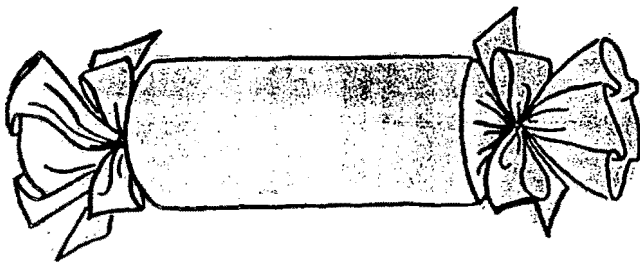

## *Covering Lid and Box Separately (Grade 7)*

To cover the box, cut paper 2 inches wider than the box and long enough to reach around it. Spread paste, or tape, along top and bottom edges of box. Then wrap the band of paper completely around the four sides. Clip corners. Fold 1 inch of the paper over the top edge of box and paste, or tape, lightly to hold the edges. Cover the lid with the same or contrasting paper, allowing corners and make a neat overlap. When finished, the lid can be decorated as shown in (b). Combine papers for unusual effects; paper printed on box, plain paper on lid and vice versa. Or plain color on half of the box, another plain color on the other half. Ribbons can also give contrasts.

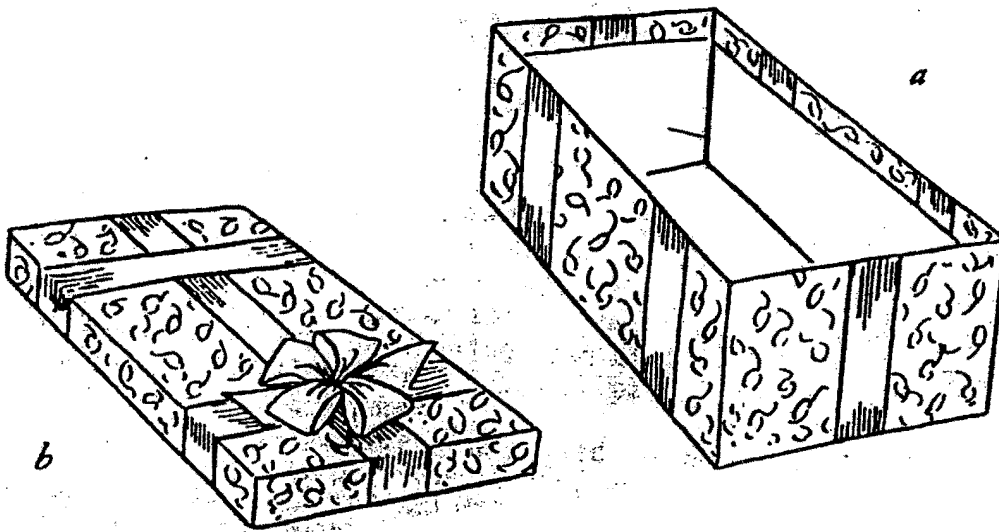

## *Making Your Own Gift Wrapping Paper (Grade 8 & up)*

Give that gift a special wrap with gift paper you can create with only a short amount of time, energy, and money. You can print reams of your own unique paper. Using shelf lining paper, and paper toweling, in both white and pastel colors, make your own designs using one of these methods: roller painting, string pulling, vegetable/fruit/utensil printing, and dip dyeing. Or any other ideas you come up with.

## **Roller Painting**

Use different widths of rollers to decorate rolls of shelf paper. To achieve startling effects, follow these directions. Allow yourself an adequate work area, such as a 3 to 6 foot table; painter's sawhorse with boards are ideal. Pour a variety of water-based paints into bowls or saucers, and lay out newspaper to protect the floor. Then unroll the shelf paper into 3 to 6 foot lengths; cut it with scissors and begin painting the design.

One roller is all you need to create bold stripes. Alternate the widths of the stripes using the roller's edge to make a very narrow stripe, or create a checkerboard motif by rolling a roller for a few inches and then lifting it from the paper. The fact that the color blocks are uneven is far from a drawback; it contributes to the primitive look.

Use two rollers of different widths simultaneously, to cover the entire area of the paper with contrast-ing colors. Try using two rollers of the same width running them crisscross, vertically, or horizontally along the shelf paper. Just experiment with the rollers and see what you come up with.

After you've finished the roller prints, lay the lengths of paper on the floor for a few minutes to let the colors set. While they are still damp, pick up each piece separately and hang it over a basement laundry line. Leave the pieces overnight for drying. When dry, roll them together for future package wrappings.

## **String Pulling**

String pulling is a very ancient method of decorating paper. Again, use shelf paper or ordinary brown wrapping paper. Cut off one or two yards of paper (here shorter lengths of paper are handier to work with. Assemble ordinary postal string or heavier twine if you wish to make thicker outline. Cut the string no longer than an arm's length. You will be coiling some the string on the paper, with the rest hanging over). Dip the string in poster paint, squeeze out the excess and lay it in swirls and loops on the paper.

Fold a square of newspaper over the coiled string, exerting a gentle pressure with the left hand. Quickly pull the string, which extends from between the newspaper and the shelf paper toward you with one continuous motion. Remove the newspaper and let the design dry thoroughly. Don't use more than two colors.

## **Fruit, Vegetable, and Utensil Print Paper**

Fruit, vegetable and utensil print paper can feature a wild collection of fruits, vegetable and utensils that can be found in most supermarkets any time of the year.

To make these papers, use some new variations of the well-known potato printing technique. For potato printing, cut the vegetable in half and make a few notches with a paring knife. If the potato is not particularly shapely, trim the edges into any desired outline. Dip the potato in paint and press it to the paper. For a striking effect, alternate rows of vegetable paints with bands made from a roller.

After you've mastered the potato print, graduate to the other fruits and vegetables. try a cabbage cut in wedges; a Bermuda onion cut in half; or make wagon wheels from lemon slices. Also try designs made with kitchen hardware, wire whisks, cookie cutter and gelatin molds.

## **Kitchen Paper Toweling and Liquid Dye**

Kitchen paper toweling and liquid dye make simple but sensational shadow designs. The end result will resemble an expensive batik or tie-dye paper. Best of all you can turn out yards of superb-looking paper in a few hours. To make a large amount of this type of wrapping paper, take cardboard core from the inside of a regular size roll of paper toweling. Re-roll about 3/4 of the roll lightly. Fill a small basin with 1/2 cup dye and like amount of water. Repeat the process with another color at the other end of the toweling. Unroll the paper carefully and loop it over a clothesline for drying.

For shorter lengths of dip-dye wrapping paper, you'll find that folding six or eight of the squares into a very small compact square and immersing each corner in a different color of dye for 1/2 minute will produce a feathery effect. Or, fold paper toweling into triangles and dip the corners of the triangles.

If you're the kind of person who really likes to get your hands into a project, making gift wrapping paper provides you with an excellent opportunity. Here are a few fun ideas for you consideration: Dip the palm of your hand in poster paint and make hand prints all over shelf paper or brown wrapping paper. This design is created by a clenched fist print, four fingers and a thumb print. Splash them at random all over the paper or arrange them so that they appear to march over or around the gift box.

These different designs should give you a few ideas of your own. Put them into action by working on your own personalized gift wrapping paper. The work will seem like play.

## *How and Where to Place Bows on the Package*

Always place the bow on the package with an eye to balance and proportion. For instance, on a square or round box, the bow will look best if placed directly in the center, but on all other shapes place bow at the side, end, or along the edge. This asymmetric line is more pleasing. Do not use a bow so large that it overpowers the package. Use big bows on big boxes, smaller bows on smaller ones. Experiment with your own ideas until you get an effect or arrangement that pleases you. There are endless possibilities.

Bows may be tied wired, pinned, taped or pasted to the package.

### *Tying or Wiring*

Tie bow to box in one of the following two ways:

- 1) Either place the center of the loops on the-knot of the package and tie;
- 2) Slide the ends of the wire or thread, with which you have wound the loops, under the ribbon already on the package and twist it under the bow.

### *Pinning*

You can pin wide ribbon bows to the box if there are no bands of ribbon onto which to tie it. Push pins slantwise through the underneath loops near the center of the bow. Use three or four pins pushed in at different angles. They will hold bow firmly and are easily removed. Slip small pieces of Scotch tape through a few of the bottom loops near the center of the bow. Use narrow strips of tape and allow the ends to extend far enough to hold bow securely to the box.

### *Pasting*

Flat bows are best suited for attaching to boxes in this manner. Use household cement, mucilage, or library paste and spread it lightly on the box. then place bow and loops on it. Press gently but firmly until it sets.



# Gift Wrapping RECORD SHEET

Year \_\_\_\_\_

Name \_\_\_\_\_ Birthdate \_\_\_\_\_

Address \_\_\_\_\_  
(street, road, rural route, box) (city) (state) (zip)

County \_\_\_\_\_ Township \_\_\_\_\_ Club \_\_\_\_\_  
(of participation)

Years in 4-H \_\_\_\_\_ Years in this project \_\_\_\_\_  
(including this year) (including this year)

I have reviewed this record and believe it to be correct:

Member Signature \_\_\_\_\_ Date \_\_\_\_\_

Parent Signature \_\_\_\_\_ Date \_\_\_\_\_

Leader Signature \_\_\_\_\_ Date \_\_\_\_\_

1. Explain the activities that you completed for this project. (Be specific!):

2. What theme and occasion did you choose for your wrapped package to exhibit? Why?

\_\_\_\_\_

3. List at least three things that you learned while working on the Gift Wrapping Project.

\_\_\_\_\_  
\_\_\_\_\_  
\_\_\_\_\_  
\_\_\_\_\_

4. List something about this project which you still want to learn more about.

\_\_\_\_\_  
\_\_\_\_\_  
\_\_\_\_\_

5. Demonstrations given (List title or subject and audience).

\_\_\_\_\_  
\_\_\_\_\_

